

OPERATION AND INSTALLATION MANUAL

**GENESIS SERIES
COMPRESSION MOLDING PRESSES
MODEL G30H-18-CX
SERIAL# 10884**

**IMPORTANT: PLEASE READ CAREFULLY BEFORE
ATTEMPTING TO INSTALL OR OPERATE EQUIPMENT**

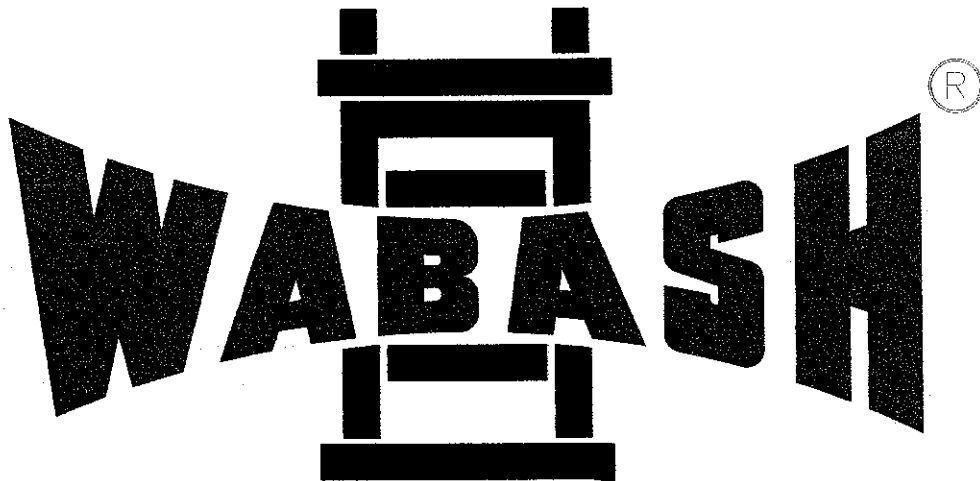

**WABASH MPI
PO Box 298
1569 Morris Street, Wabash, Indiana 46992-0298
Phone: 260-563-1184 Fax: 260-563-1396**

NOTE: Performance figures stated in this manual are based on a Standard Atmosphere of 59° F. (15° C.) and 29.92" Hg (10,331 Kg/m²) at sea level and using 60 Hz electrical current. All of these factors are important considerations when selecting a hydraulic press. **WABASH MPI** can advise you on proper selection and sizing of systems for the operating environment at your location.

WABASH MPI is committed to a continuing program of product improvement. Specifications, prices, appearance, and dimensions described in this manual are subject to change without notice.

WABASH MPI

All Rights Reserved

Part #: 998.10884

REV. 0

Effective: 5-18-07

TABLE OF CONTENTS

SECTION ONE INTRODUCTION		1-1
1.1	INTRODUCTION.....	1-1
1.2	MODELS COVERED	1-1
1.3	OPTIONAL FEATURES.....	1-1
1.4	CUSTOMER SERVICE	1-2
1.5	UNPACKING and INSPECTION	1-2
1.6	SHIPPING DAMAGES	1-3
SECTION TWO SAFETY		2-1
2.1	MANAGEMENT SAFETY GUIDELINES	2-1
2.2	GENERAL OPERATING SAFETY	2-1
2.3	SAFEGUARDING THE POINT-OF-OPERATION	2-2
2.4	SUPERVISION AND SAFETY ENFORCEMENT.....	2-3
2.5	INSPECTION AND MAINTENANCE.....	2-3
2.6	TRAINING	2-5
2.7	SAFETY EQUIPMENT DIRECTORY	2-5
2.8	POINT-OF-OPERATION SAFETY DEVICES.....	2-6
2.9	SAFETY PRECAUTIONS	2-7
2.10	SAFETY GUIDELINES FOR OPERATORS	2-7
2.11	BEFORE STARTING MACHINE	2-8
2.12	STARTING THE MACHINE.....	2-9
2.13	MACHINE OPERATION	2-9
SECTION THREE INSTALLATION		3-1
3.1	WORK RULES.....	3-1
3.2	FOUNDATION.....	3-1
3.3	UNLOADING AND LIFTING	3-2
3.4	CLEANING	3-2
3.5	LIFTING THE MACHINE	3-2
3.6	LEVELING THE MACHINE.....	3-4
3.7	CONNECTING THE ELECTRICAL SERVICE	3-5
3.8	WATER AND DRAIN CONNECTIONS - Hydraulic Oil Cooling.....	3-7
3.9	HYDRAULIC OIL & LUBRICATION	3-12
3.10	LUBRICANT SPECIFICATIONS AND SUPPLIES	3-12
3.11	GREASE	3-12
3.12	FILLING THE OIL RESERVOIR.....	3-13
3.13	RECOMMENDED HYDRAULIC OIL	3-14
3.14	CHECK FOR PROPER PUMP MOTOR ROTATION	3-15
3.15	MACHINE SPECIFICATIONS.....	3-15
3.16	EXHAUST GAS OR DUST REMOVAL	3-15

SECTION FOUR OPERATION 4-1

4.1	OPERATOR SAFETY	4-1
4.2	PRE START-UP CHECKS	4-1
4.3	OPERATOR CONTROLS	4-1
4.4	START-UP	4-3
4.5	SHUT DOWN.....	4-3
4.6	MANUAL OPERATION.....	4-4
4.7	SEMI AUTOMATIC OPERATION.....	4-5
4.8	PLATEN REHEAT (Heated Platens only)	4-7
4.9	TEMPERATURE CONTROLLERS	4-8
4.10	“OPERATOR INTERFACE” – AB “PANELVIEW 300 MICRO”.....	4-10
4.11	“SLOW DOWN” AND “RESET” SWITCH ADJUSTMENT	4-20

SECTION FIVE MAINTENANCE 5-1

5.1	SERVICING THE HYDRAULIC SYSTEM.....	5-1
5.2	SYMPTOMS OF CONTAMINATED HYDRAULIC OIL.....	5-2
5.3	HEATER REPLACEMENT (WHERE APPLICABLE).....	5-2
5.4	PLATEN DAYLIGHT ADJUSTMENT.....	5-3
5.5	PLATEN PARALLELISM	5-6
5.6	MOLD SIZE VERSUS TONNAGE CHART	5-8
5.7	RECOMMENDED SPARE PARTS	5-9
5.8	RECOMMENDED PREVENTIVE MAINTENANCE.....	5-9

SECTION SIX TROUBLESHOOTING 6-1

6.1	PRESS WILL NOT CLOSE	6-1
6.2	PRESS PLATENS WILL NOT HEAT.....	6-2
6.3	PRESS WILL NOT BUILD PRESSURE	6-3

SECTION SEVEN WABASH MPI SERVICES 7-1

7.1	TECHNICAL ASSISTANCE.....	7-1
7.2	RETURNED MATERIAL POLICY.....	7-2

SECTION EIGHT WARRANTY 8-3

8.1	WARRANTY RETURNS	8-3
8.2	WARRANTY	8-3

SECTION NINE GLOSSARY 9-1

9.1	GLOSSARY OF TERMS	9-1
-----	-------------------------	-----

1.1 INTRODUCTION

We are pleased to supply WABASH Equipment for your operation. WABASH presses are used in many applications including research and development, production, and quality testing. Thousands of presses are in use all over the world in many applications in the electronics, automotive, and aerospace fields wherever pressing is required.

1.2 MODELS COVERED

This manual provides instructions for the installation and operation of WABASH MPI "GENESIS" series hydraulic presses ranging in size from 15 to 150 tons.

Standard unheated presses do not include platens. The mold or die is attached directly to the bolsters with the optional tapped holes or T-slots, if necessary.

Presses equipped with heated platens, include steel platens, cartridge heaters and full insulation. Mounting holes and T-slots are optional.

1.3 OPTIONAL FEATURES

A variety of options are available for the "GENESIS" Series presses. WABASH MPI can tailor your equipment to meet the exact requirements of the task being performed.

- STANDARD HEATED PLATENS with digital temperature controllers to precisely control platen temperature.
- ADDITIONAL TEMPERATURE CONTROL ZONES for controlling platen temperatures within a narrower range of accuracy.
- PRESSING SPEED CONTROL to accurately control the clamping speed of the press after Clamp Sealed or activation of the Slowdown proximity switch.
- LOW PRESSURE SYSTEM allows the clamp to be closed under low pressure for a possible preheat application.
- UPPER AND/OR LOWER CORE LIFTERS for hydraulically or mechanically lifting mold cores, or ejecting parts.
- LOWER SLIDING PLATEN for indexing the bottom mold half out to the operator for ease of insert placement and part removal.
- LEFT-TO-RIGHT SHUTTLE SYSTEMS for dual station operation and increased efficiencies for insert placement and part removal.

- **TAIL PUMP** for powered secondary functions. (e.g. core pull)
- **AMMETERS** for heater burn-out detection.
- **VACUUM PUMPS** for evacuating mold cavities.
- **CENTRALIZED LUBRICATION SYSTEMS** for ease of maintenance.

There were many variables considered in the selection of your molding press: including type of materials, cure time, ambient air temperature, molding pressure required, cure temperature, cooling requirements, and the altitude at the processing site.

Should your operating environment change, WABASH MPI can advise you on necessary equipment, as well as cure time and temperature modifications.

NOTE: Many other options and features may be incorporated into your WABASH MPI machine. Special manual pages will be provided to cover the use of these features.

1.4 **CUSTOMER SERVICE**

The intent of this manual is to familiarize the operator and maintenance personnel with this equipment and help your organization get the maximum service from your press. If you have any questions regarding installation, service, repair, custom equipment or applications, please do not hesitate to call or write for the information required. Prices for presses, accessories, or repair parts will be furnished promptly on request.

NOTICE: If you desire to use a press for an application other than that for which it was purchased, please contact our factory to verify compatibility of the equipment with the new process. Misapplication of the equipment could result in injury to the operator or damage to the equipment.

1.5 **UNPACKING and INSPECTION**

The WABASH Press should be inspected for possible shipping damage. If the container and packing materials are in reusable condition, save them for return shipment, if necessary.

Thoroughly check the equipment for any damage that might have occurred in transit (such as broken or loose wiring or components, loose hardware, mounting screws, etc.) Refer to the following section in case of damage, loss, shortage, or incorrect shipment.

1.6 SHIPPING DAMAGES

A. Freight, Express or Truck Delivery

IMPORTANT: According to the contract terms and conditions of the carrier, the responsibility of the shipper ends at the time and place of shipment. The carrier then assumes full responsibility for the shipment.

1. Notify your local agent of the transportation company if there is damage.
2. Hold the damaged goods with the container and packing for inspection by the examining agent. Do not return any goods to WABASH MPI prior to the inspection and authorization of the transportation company.
3. File a claim against the transportation company. Substantiate the claim by referring to the agent's report. A certified copy of our invoice is available upon request. The original Bill of Lading will be attached to our original invoice. If the shipment was prepaid, write us for a receipted transportation bill.
4. Advise WABASH MPI Service Department at (260) 563-1184, or the Customer Service Department at regarding your wish for replacement.
5. Hold the damaged item(s) until a RMA number is issued and shipping instructions are received from our Service Department.

B. Parcel Post Shipment

1. Contact your local UPS or Federal Express office regarding damage and insurance claims.
2. Hold the damaged goods with the container and packing for possible inspection by postal authorities.
3. Hold the damaged item(s) until a RMA number is issued and shipping instructions are received.

C. United Parcel Service or Federal Express

1. Contact your local UPS or Federal Express office regarding damage and insurance claims.
2. Retain the container and package.

3. Notify WABASH MPI Service Department at (260) 563-1184, Ext. 238, immediately.
4. Hold the damaged item(s) until a RMA number is issued and shipping instructions are received.

D. Shortage

1. Check the packing list. The apparent shortage may be intentional, and back ordered items will be noted on the packing list.
2. Inspect the container and packing material to see if smaller items have been missed during unpacking.
3. Determine that the item was not taken from the area before the shipment was checked in.
4. Notify WABASH MPI immediately of the shortage.

E. Incorrect shipment

1. If the shipment was not what you ordered, contact the WABASH MPI Sales Department at (260) 563-1184, immediately. Include the order number and item descriptions.
2. Hold the incorrect item(s) until a RMA number is issued and shipping instructions are received.

F. Returns

DO NOT RETURN ANY DAMAGED OR INCORRECT ITEMS UNTIL A RMA NUMBER IS ISSUED AND SHIPPING INSTRUCTIONS ARE RECEIVED FROM WABASH MPI.

2.1 MANAGEMENT SAFETY GUIDELINES

It would be impossible to cover every situation that could arise in the use of molding machines, this data is not intended to be complete, nor is it presented in any particular order of importance. It is good, safe practice to evaluate the safety concerns of every molding setup and operating procedure **before** starting the machine.

These guidelines are intended to define and point out specified areas of responsibility that should receive the participation and leadership of all levels of management concerned with machine operation. General and specific safety guidelines and cautions are included here and throughout the manual for your protection and to help avoid injury to you and to your co-workers. You are responsible for evaluating the total manufacturing process and identifying and implementing the best method of protecting the operator from injury at the point of operation in accordance with current federal, state and local codes and standards.

Machine owners, managers and supervisors, must accept the responsibility for the safe operation of the machines under their control. Read and understand the safety guidelines and checking procedures outlined in this section and in the sections for operators, die setters and maintenance personnel. Establish and promote a program of safety objectives with defined employee responsibilities that assure safe machine working practices in your plant.

Whether new to machines, or with many years of operating experience, this section is for your benefit.

It is your responsibility to immediately report any unsafe condition or unusual machine performance to your supervisor.

The terms **NOTICE**, **CAUTION**, **WARNING**, and **DANGER** have specific meanings in this manual. As explained in Section 2-9.

2.2 GENERAL OPERATING SAFETY

Management should promote safe practices and safe machine operating procedures by establishing an effective plant safety program.

A knowledgeable and well-trained safety coordinator should be responsible for plant safety requirements, regulations and enforcement.

The safety coordinator must investigate all accidents and "close calls". The causes should be analyzed, corrective action taken and accurate records maintained.

Establish machine safety rules and inform each employee of his responsibilities.

Display in prominent locations, the procedures to be followed in case of accidents. List names, addresses, and phone numbers of physicians, hospitals and personnel who are to be notified.

It is the employer's responsibility to provide an adequate work area around the machine that is clean, safe and uncluttered.

Provide safe and convenient methods and procedures for material handling.

Do not allow a machine to be operated if it is poorly maintained, malfunctioning or in need of guards or safety devices that protect the operator from potential hazards.

Pay strict attention to all caution, warning, and danger signs.

Do not wear loose clothing or jewelry of any kind which could get caught in moving parts.

Never reach into moving parts to clear a jam of any type.

2.3 SAFEGUARDING THE POINT-OF-OPERATION

1. It is the employer's responsibility to evaluate each molding setup and to determine and implement the best method of protecting the operator from injury at the point-of-operation.
2. Each molding application must be examined and evaluated to determine which type of safeguarding offers maximum operator protection.
3. The employer should become familiar with the many types of safety devices available in order to determine which type offers maximum operator protection for each molding application.
4. The use of automated loaders is highly recommended for handling work loads. Provisions for safe material removal are equally as important as safe feeding method.
5. Never allow machine guards or safety devices to be bypassed or removed.
6. Do not release the machine for production before installing and testing all protective guards, covers and safety devices.
7. Evaluate all point-of-operation guards, safety devices and work procedures frequently while the machine is in operation. Immediately correct any unsafe condition.

2.4 SUPERVISION AND SAFETY ENFORCEMENT

1. All levels of management must enforce every safety rule and regulation. To make machine safety effective, every violation should be reported, recorded and result in appropriate disciplinary action.
2. Never allow any operator, regardless of his experience, to start a new job assignment without a complete and detailed explanation of the job and the safe procedures to be followed.
3. It is the supervisor's responsibility to maintain absolute authority over the machine controls. The actuation of the main disconnect switch, mode selector switch and other keyed switches should always be under his supervision. The keys should be removed and in his possession at all times to prevent unauthorized use or adjustment of the machine.
4. Conduct frequent inspections of the machine operations. Be sure the operator and helpers are using proper safety devices and are working safely.
5. Never allow machine guards or safety devices to be removed, altered or bypassed.
6. Never allow untrained personnel to operate the machine.
7. Never allow personnel who are under the influence of drugs or alcohol, or otherwise not physically or mentally alert, to operate the machine.
8. Never allow minors to operate or assist in the operation of a machine.
9. Be alert to unsafe machine or operating conditions. A poorly maintained machine or a machine that is malfunctioning should be shut down until the safe condition has been corrected.

2.5 INSPECTION AND MAINTENANCE

1. To maintain a high level of machine reliability and to obtain advance warning of any possible hazards or malfunctions, a daily, weekly and monthly program of machine inspection and preventive maintenance should be established.
2. A check list should be used and records maintained of all maintenance and repair work performed.
3. Only highly qualified, competent personnel should be assigned this job of inspection and maintaining the machine. They should be specifically

instructed and have thorough understanding of the controls and the operating and maintenance procedures outlined in this manual.

4. Establish and follow a safe shutdown procedure for machine inspection.
5. To ensure optimum performance and safe operating condition of the machine, careful inspections of the electrical and hydraulic systems should be made.
6. Auxiliary equipment and safeguards must be inspected and maintained in safe operating condition.
7. Releasing the machine for production after inspection and maintenance should be the responsibility of qualified personnel assigned by management.
8. Never perform maintenance or repair work until you are sure the power is turned off at the main control panel and cannot be turned back on without your knowledge. Use a padlock or other safe lockout device.
9. Wabash MPI recommends that annual calibrations and preventative maintenance checks be performed by the Wabash Service Department.

2.6 TRAINING

1. All personnel who will be associated with the operation of the machine must read and have complete understanding of the contents of this manual.
2. Management must assume the responsibility of training all personnel associated with machine operation to eliminate accidents and injuries.
3. Only employees who understand and can communicate their knowledge of the machine, its operation, its dies and safety requirements, should be assigned the responsibility of training.
4. A supervisor must be knowledgeable in machine operation, machine guarding, safety guidelines, operator supervision, job instructions, and causes of accidents. He is also responsible for promoting safe working habits and attitudes of machine operators.
5. An operator training program should include specific instructions in safety, safety devices, guarding, proper use of the machine and correct procedures in performing every machine job.
6. No operator should be given a machine assignment that they do not fully understand.
7. Only thoroughly trained and responsible personnel should be allowed to operate or work on the machine.

2.7 SAFETY EQUIPMENT DIRECTORY

In order to assist the end user select the type of additional machine guarding best suited for each installation, **WABASH MPI** has assembled the following list of manufacturers who can furnish machine guards and safety equipment. The list is not all-inclusive nor is it intended to be a recommendation or approval by **WABASH MPI** as to the merits of the products or other suitability for any particular application. This list is included in the interest of safety and to provide the end user with several sources and products in order to obtain the best possible solution for a safe machine installation.

2.8 POINT-OF-OPERATION SAFETY DEVICES

Manufacturer	Presence Sensing Device	Pull-Back Device	Interlocked Barrier Guards	Safety Blocks
Triad Controls, Inc. 174 Easy Street Carol Stream, IL 60188 708-462-0099 www.triadcontrols.com	X		X	
Rockford Systems, Inc. American Road Rockford, IL 61109-2658 800-922-7533 www.rockfordsystems.com	X		X	X
Link Electric & Safety Control Company 444 McNally Drive Nashville, TN 37211 615-833-4168	X			
Protech Systems 4035 Cheyenne Court Chino, CA 91710 714-590-9521 www.protechsystems.com	X	X	X	X
Banner Engineering Corp. 9714 10th Avenue North Minneapolis, MN 55441 612-544-3154 www.bannerengineering.com	X			
Data Instrument, Inc. 100 Discovery Way Acton, MA 01720 508-264-9550	X			
Weldotron Corporation 1532 S. Washington Avenue Piscataway, NJ 08854 201-752-6700	X			
Avalon Imaging, INC. 3417 Highway 5, Suite F Douglasville, GA 30135 800-842-4722 www.avalonimaging.com	X			
Sti 6550 Dumbarton Circle Fremont, CA 94555 888-510-4357 www.sti.com	X			
Omron Omron Management Center of America, Inc. (OMCA) Regional Management Centre 1300 Basswood, Suite 100 Schaumburg, Illinois 60173 U.S.A. 847-884-0322 www.omron.com			X	

2.9 SAFETY PRECAUTIONS

The terms **NOTICE**, **CAUTION**, **WARNING**, and **DANGER** have specific meanings in this manual.

- A **NOTICE** is used to indicate a statement of company policy directly or indirectly related to the safety of personnel or protection of property.
- A **CAUTION** indicates a potentially hazardous situation that, if not avoid, may result in minor or moderate injury.
- A **WARNING** indicates potentially hazardous situation that, if not avoided, could result in death or serious injury.
- A **DANGER** indicates an imminently hazardous situation that, if not avoided, will result in death or serious injury. This word will be limited to the most serious situations(s).

The term **IMPORTANT** emphasizes areas where equipment damage could result, or provides additional information to make a step or procedure easier to understand. Disregarding information marked **IMPORTANT** would not be likely to cause personal injury.

<p>WARNING: BEFORE OPERATING THE MACHINE Be sure that all personnel in your company who will have contact with hydraulic machine equipment thoroughly read and understand this Installation and Operation provided by WABASH MPI.</p>
--

2.10 SAFETY GUIDELINES FOR OPERATORS

This section of the manual is directed to all personnel who are associated with the operation of **WABASH MPI** Compression Molding Presses. Whether you have years of experience working with presses or whether you are new on the job, this section is for your benefit. General and specific safety guidelines and caution notes are include here and throughout the manual for your protection and to help you avoid injury to yourself and to your co-workers. Since it would be impossible to cover every situation that could arise, the following list of points is not intended to be complete, nor does the order in which they are listed relate to their importance. It is your responsibility to immediately report any unsafe condition or unusual machine performance to your supervisor.

2.11 BEFORE STARTING MACHINE

1. Never operate the machine until you have read and fully understand the safety, control description and operating sections in this manual.
2. Make absolutely sure hydraulic pump motor is off and safety blocks are in place before servicing anything inside the clamp/molding area.
3. Inspect the machine before each shift for loose, worn or broken parts. Report any unsafe conditions to your supervisor immediately and do not operate the machine until the necessary repairs are made.
4. An important part of machine safety is good preventive maintenance. Keep your machine clean and in good condition by cleaning daily.
5. Clean your work area frequently. Keep it uncluttered and free of loose tools, discarded work pieces, rags, wires, oil, grease, water or anything that can inhibit your movement or cause you to trip or fall.
6. Be sure machine guards and safety devices are correctly installed in their proper position.
7. It is your employer's responsibility to evaluate each machine operation and to determine and implement the best method of protecting you from injury at the point-of-operation in accordance with current federal, state and local codes and standards.
8. Never attempt to bypass or remove any point-of-operation guard or safety device on your machine. They are there for your protection.
9. Be alert for possible hazards or safety irregularities that could cause injury.

2.12 STARTING THE MACHINE

1. Never start the machine until you have made the inspections outlined in Section 2-11.
2. Before you start the machine, be sure you know how to stop it instantly.
3. Follow the start-up procedures as outlined in Section 4-4.
4. Before starting production, be sure the machine is pre-heated to process temperature and then test-cycle the machine to verify proper operating sequence. Observe carefully that all functions are properly sequenced by the machine control. Report any unsafe condition or unusual machine performance to your supervisor.

2.13 MACHINE OPERATION

1. Never place hands, fingers, arms or any part of your body in the machine daylight area while it is moving, or near loading and unloading automation systems.
2. Pay attention to the warning tags on the machine. They are there for your benefit.
3. Do not reach around, under or over any guards while the machine is running.
4. Never bypass, remove or alter any machine guards or safety devices.
5. Never stack parts or other objects on the bolster or platens. Use part containers and scrap bins of sufficient size to accommodate the job.
6. Use care and judgment in the work you are doing. Take the time to evaluate the operation - Is it safe? **Are you working a safe procedure?**
7. Stay alert at all times. Do not become overconfident and careless. Avoid inattention, pre-occupation and distractions.
8. If you leave the machine for any length of time, always check to make sure the set-up parameters are as you left them before restarting the machine. They may have been modified during your absence.
9. Know who or where to call for immediate help in the event of any emergency or injury.
10. Have all injuries treated, no matter how small.

3.1 WORK RULES

The installation, operation, and maintenance of this equipment must be conducted in accordance with all applicable work and safety codes for the installation location. This may include, but is not limited to OSHA, NEC, BSI, IEC, CEN/CENELEC, VDE, TUV, CSA, UL, NFPA and any other local, national, and international regulations.

Read and follow these operating instructions when installing, operating, and maintaining this equipment. If the instructions become damaged or unreadable, additional copies can be purchased from **WABASH MPI**.

To assist in the installation and operation of this press, an assembly drawing (including part numbers) is included in the appendix of this manual.

CAUTION: Only qualified personnel who are familiar with this equipment should operate or work on this press.

WARNING: Work only with approved tools and devices.

WARNING: Disconnect the electricity before maintenance or service. If the press is installed with a power cord that can be disconnected, unplug it. If the press is permanently wired to a power main, a fused power disconnect must be installed to allow the disconnect to be locked in the OFF position.

3.2 FOUNDATION

General assembly drawings are forwarded in advance of the machine shipment. The drawings show limiting dimensions and other details. Reinforced concrete details are to be determined by the customer to suit local soil conditions. The shipping skid mounting holes are not recommended for the attachment of machine leveling feet. A minimum of three feet must be allowed around the machine to provide access for servicing. When determining the location of the machine, the following additional requirements must be considered.

The foundation must comply with applicable local codes regarding the load per square inch rating necessary to support the machine. Consult your building contractor or foundation consultants.

Adequate space must be provided for the addition of any peripheral equipment that may be used with the machine.

3.3 UNLOADING AND LIFTING

All machine components should remain on shipping skids until ready for re-assembly.

WARNING: Check capacity of crane or hoist. Be sure it is capable of safely lifting the total weight of the machine.

Check the condition of cables, hooks and other lifting equipment. Adjust cable length so the machine will remain upright while suspended.

WARNING: Always use extreme caution when moving the machine. Do not lift one end only as this may cause the machine to fall over.

CAUTION: Do not remove any blocking or fasteners from the machine until it is set in its permanent location. Failure to follow this instruction may result in machine damage or personal injury.

3.4 CLEANING

Soon after delivery, each shipment should be thoroughly cleaned and staged near the machine foundation ready for re-assembly. Cleaning should be done using a good grade of commercial solvent to remove the rust preventive and any dirt that may have accumulated on the platens and guide rods during transport.

3.5 LIFTING THE MACHINE

DANGER: Failure to follow the following guidelines may result in fatal injury.

It is **STRONGLY** recommended that you employ a rigger who has experience installing this particular type of equipment. In addition, the following guidelines must be followed when lifting the machine:

- If you are using an overhead crane, make sure the slings you are using are rated for weight capacities greater than the machine weight. (The term "sling" as used in this section refers equally to slings and chains.) The actual weight capacity of any sling is affected by the angle between the sling and the load it is lifting. This factor must be taken into account when determining whether or not a sling can lift a certain load. In order to maintain the maximum weight rating of a sling, the sling-to-load angle should be kept as close to 90° as possible. The following figure illustrates how the lifting capacity of a sling is decreased as the sling-to-load angle decreases.(see figure 3-1)

- Before lifting the machine, make sure that all moving components are properly blocked to prevent them from moving while the machine is being lifted.
- Lift the machine with an overhead crane only if there are tapped holes in the bolster of sufficient size to use with lifting eyebolts. Then using an appropriate lifting means, attachment can be made by hook/sling to the clevises for lifting from above.
- On models supplied with lifting tubes built into the base of the machine, a forklift of suitable capacity, and with **forks long enough to extend fully beneath the frame**, can be used to lift and move the machine.
- To lift the machine with a fork lift, spread the forks apart to match the lifting holes in the base of the machine. Lift the machine from the operator side, raising the machine only as high as necessary. Do not lift the machine higher than necessary.

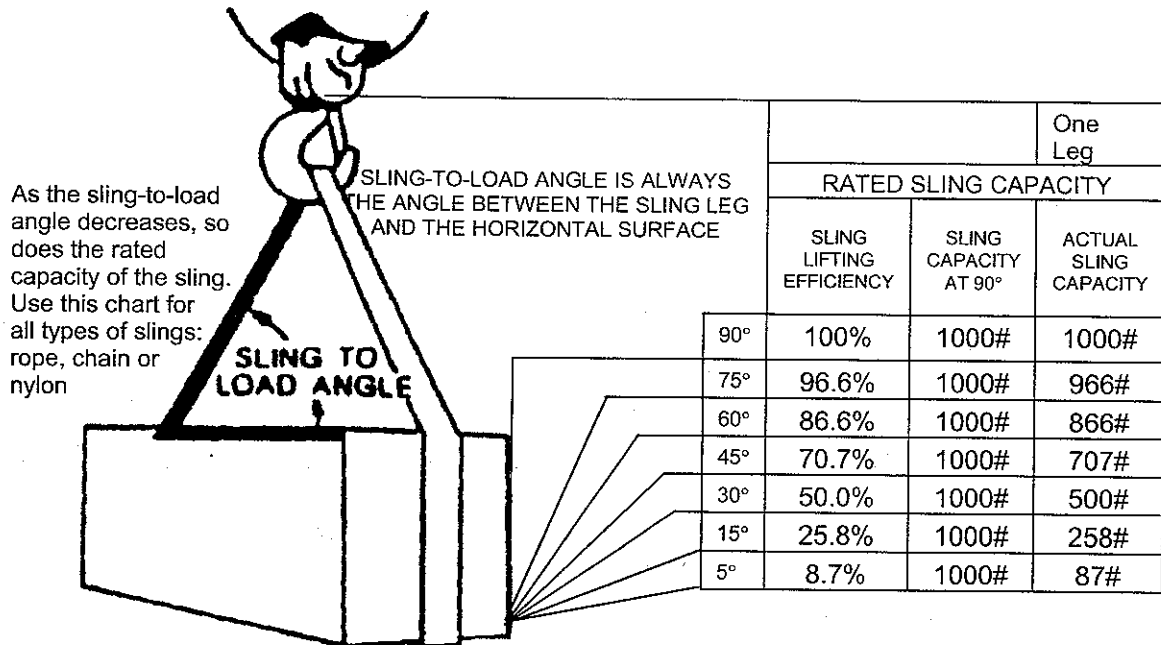

LIFTING THE MACHINE - Figure 3-1

DANGER: Never place any part of your body under a suspended load. Failure to follow this instruction may result in serious personal injury.

IMPORTANT: Please contact the factory for special needs, advice, or consultation about rigging.

1. Do not shorten the slings with knots, bolts or any other unproved methods.
2. Never use a damaged sling.
3. Correct kinks and twists in the slings before lifting.
4. Make sure that the sling is securely attached to the load.
5. Pack any sharp corners with material of sufficient strength to withstand the load and protect the sling.
6. Attach the slings to the center of the lifting hook. Do not lift any load by attaching the slings to the point on the lifting hook.
7. Make sure that the load is free to move before attempting to lift it. Also, make sure that there is a clear spot for depositing the load before lifting it.
8. Avoid shock loading the slings - especially when working at temperatures below 40°F.
9. Never place your hands or fingers between the sling and the load.
10. Never place a suspended load over any part of another person's body.

3.6 LEVELING THE MACHINE

The machine must be leveled utilizing the platens or bolster as the leveling surface. When checking the machine level, use a graduated spirit level, or any good quality level. The machine should be as level as possible.

WARNING: Turn off and lock out the main disconnect switch before you begin the leveling procedure. Failure to follow this instruction may result in serious personal injury.

IMPORTANT: Failure to properly level the machine may result in machine damage. The machine must be leveled when it is installed, and the level should be checked at least once a year after installation.

When making adjustments to the machine level, always retract the screws on the necessary (optional) leveling pads (lower the machine). **Do not attempt to level the machine by extending these screws.**

3.7 CONNECTING THE ELECTRICAL SERVICE

WARNING: Only a qualified electrician should hook up or perform maintenance on the electrical system. Read and completely understand the electrical schematics for the machine before beginning.

DANGER: Turn off all electrical power to the circuit before making electrical connections. Failure to follow this instruction may result in fatal injury.

A positive earth grounding system for the machine/control is required for proper and safe operation. A correct grounding system minimizes the introduction of random electrical noise into low voltage, quick response electronic circuits. This noise could cause erratic operation.

The recommendations of this section are intended to conform to the grounding requirements of the National Fire Protection Association publication **NFPA-79-National Electrical Code**. The machine must be grounded in conformance to these codes and applicable national, state and local electrical codes.

All parts of the system, machine and control are tied to a single ground terminal of the ground block, which is located inside the door of the electrical cabinet. This terminal must be grounded upon installation of the machine. The methods of grounding which follow are listed in the order of preference ("a" is the most preferred, "b" is next, and "c" is least preferred).

- a. The central ground terminal is connected via a stranded conductor to the protective conductor.
- b. The central ground terminal is connected via a stranded conductor to a building column or electrical mass that is determined to be at "true earth" potential.
- c. The central ground terminal is connected via a stranded conductor directly to a grounding electrode installed for use with the particular machine to be installed. A separate grounding electrode should be used for each machine.

Water pipes should not be used as grounding electrodes since the use of plastic pipe and sealant may result in an inadequate ground.

The grounding conductor should be sized to conform to **NFPA-79** requirements and any applicable national, state, and local codes. The conductor size listed in these codes is the minimum for safe operation of the equipment. However, larger size AWG No. 2 is recommended to minimize electrical noise.

If grounding electrodes are used, the maximum resistance to true earth potential should be three ohms or less. The resistance to true earth should be checked at the time of installation and after the third, sixth, ninth, and twelfth month of operation. This resistance should be checked annually thereafter, and any time the grounding electrode installation is altered. Refer to **NFPA-79** for specific grounding electrode requirements.

WARNING: The earth ground must meet local code requirements. If this ground is not properly connected, erratic machine operation could result or a shock hazard could exist. Failure to follow this instruction could result in serious personal injury or machine damage.

Check the electrical prints for correct power requirements (voltage, phase, and frequency). If in doubt, check the electrical cabinet tags. The machine will operate with uniform accuracy at voltages within $\pm 10\%$ of normal, with maximum phase imbalance of 5%. This voltage tolerance is based on a line supply that is either constant at some voltage within the range, or that varies slowly within the range. Sharp line voltage changes (transients) caused, for example, by starting a welder or heavy compressor, may adversely affect performance of the equipment and must be avoided. Although the machine and the control are designed to minimize these effects, sharp drops and surges are dangerous. Additional equipment required to regulate the power supply, and to provide voltages within the acceptable tolerances, should be installed in the electrical system of the factory by the customer.

Connect the proper voltage to the circuit breaker in the electrical cabinet. (Refer to the wiring diagrams shipped with the machine.)

WARNING: Failure to connect the proper voltages to the machine may result in personal injury or machine damage.

WARNING: If, for any reason, the electrical work cannot be completed and the machine must be left unattended, always lock the main disconnect switch in the [OFF] position. Never bypass or wire around safety limit switches. Failure to heed these warnings may result in personal injury or machine damage.

3.8 WATER AND DRAIN CONNECTIONS - Hydraulic Oil Cooling

A water supply line and a drain line must be connected to the heat exchanger located on the hydraulic power unit on the rear of the machine.

Supply 5-6 GPM (19-23 LPM) of 60°-70°F (16°-21°C). water to 3/4" NPT on inlet side of the heat exchanger. Plumb 3/4" NPT from outlet side of heat exchanger to drain connection, or water recovery system. If the optional inlet strainer and WaterSaver valve are not purchased, then the customer should supply a 3/4" NPT water line strainer on the inlet equipped with some sort of throttling valve on the outlet to regulate water flow passing through the heat exchanger.

In addition, the water supply piping should be insulated to eliminate condensation.

If your machine is equipped with a WaterSaver valve on the outlet of the heat exchanger, it has been adjusted at the factory for optimum oil temperature.

If the oil temperature is too hot or cold, adjust the WaterSaver valve by turning the adjusting screw in the direction indicated on the valve body.

3.8.1 COMPRESSED AIR AND WATER CONNECTION - Platen Cooling

(Required for Optional Platen Cooling)

Connect a water line to the 3/4" NPT port in the solenoid valve labeled SOL-W1 (typically located on the top bolster). A water supply of 10 GPM @ 55° F. (38 LPM @ 13° C.) and 40 to 60 PSI (2.7-4.1 bar) is required for proper cooling.

Connect a clean, dry, regulated compressed air source to the 1/2" NPT port in the solenoid valve labeled SOL-P1 (typically on the top bolster). Approximately 0.5 SCFM (.014 M3/min.) of air is required for each cooling cycle.

Refer to the drawings on the following pages.

IMPORTANT: The inlet manifold is typically mounted on the top bolster. Air and water solenoids should be plumbed with flexible connections to allow daylight adjustment, platen leveling and clamp closing.

The outlet manifold (typically located on the lower left side of the press) must be vented for steam through a 3/4" NPT steel pipe.

DO NOT vent with copper or plastic. Use only steel pipe and install to standard steam specifications.

IMPORTANT: The outlet manifold must be plumbed downward to drain the platens properly. If the manifold is plumbed upward, WABASH MPI recommends the use of a check valve to eliminate back flow into the platens, or a pump to recirculate the drain water.

IMPORTANT: WABASH MPI will not guarantee proper cooling if the drain is not plumbed according to WABASH MPI recommendations.

A pressure gauge and regulator are recommended components for your plant air supply.

A manual shut-off valve in each line will aid in future maintenance procedures.

IMPORTANT: Verify that the water pressure is greater than the air pressure or the water will not enter the platen cooling channels. Set air regulator BELOW water pressure. (approximately 10-15 PSI (.69-1.03 bar) less than water pressure) but at a minimum of 20 PSI.

The following is to be used when determining the cooling media required for the temperature being used.

AIR ONLY when platen temperature is above 650° F.(343 ° C.)

AIR/WATER MIX when platen temperature is between 650° & 350° F. (343° & 177° C.)

WATER ONLY when platen temperature is below 350° F. (177° C.)

NOTE:

Wabash MPI/Carver Inc. test all press platen cooling cycles using a cooling medium with a specific heat of .995. The cooling medium temperature is set to 55 F (13C) for all cooling test except ASTM D4703 class 5, which is set at 45F (7C). If your cooling medium has a specific heat of less than .995 or is at a different temperature, then the cooling rates achieved at the factory cannot be guaranteed at your facility.

Water Treatment Considerations

Water treatment is an integral part of the system. In some locations, water may cause large deposits of scale, erosion, algae, and/or corrosion. A system using a good quality scale and corrosion inhibitor is recommended.

The use of poor quality water may result in inefficient operation, heat exchanger damage, and pump seal damage. Consult a qualified water treatment specialist to determine whether treatment is needed.

Wabash MPI/Carver Inc. does not recommend the use of deionized water for cooling due to possible corrosion in the system.

TYPICAL DRAIN AND SUPPLY LINE HOOK-UPS
FOR PRESSES THAT HAVE TO BE DRAINED UPWARD
TYPICAL AIR INSTALLATION @ 40% HUMIDITY AND 70 °F
RUN FULL SIZE LINES OR BIGGER TO COMPONENTS.

NOTE:
FOR DRAIN LINES THAT HAVE TO BE RUN UPWARD
A CONDENSATE RETURN PUMP SYSTEM IS RECOMMENDED
TO GET PROPER COOLING.
USE ONLY STEEL PIPE FOR THESE CONNECTIONS
REFER TO MANUAL FOR ADDITIONAL INFORMATION.

TYPICAL CONNECTIONS FOR
A GENESIS STYLE PRESS

SUPPLY 5 GPM WATER @ 55° TO
1/2" NPT SOL. VALVE
AND AIR @ 15-20 PSI LESS THAN
WATER PSI TO 1/2 NPT SOL. VALVE.
APPROXIMATELY 0.5 SCFM OF AIR
IS NEEDED FOR EACH COOLING CYCLE

DETAIL "A"

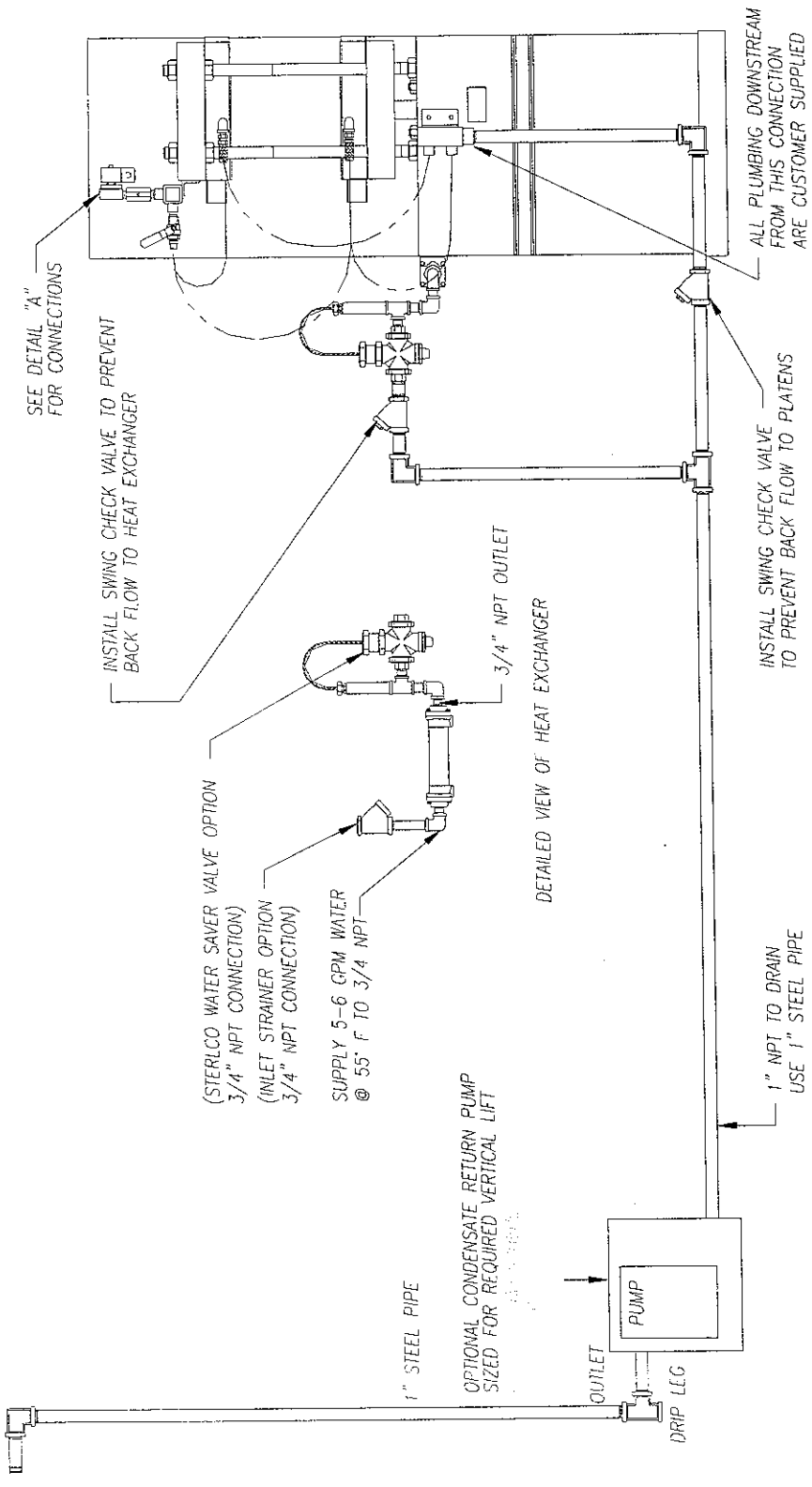

SEE DETAIL "A"
FOR CONNECTIONS

INSTALL SWING CHECK VALVE TO PREVENT
BACK FLOW TO HEAT EXCHANGER

(STERILCO WATER SAVER VALVE OPTION
3/4" NPT CONNECTION)
(INLET STRAINER OPTION
3/4" NPT CONNECTION)

SUPPLY 5-6 GPM WATER
@ 55° F TO 3/4" NPT

3/4" NPT OUTLET

DETAILED VIEW OF HEAT EXCHANGER

INSTALL SWING CHECK VALVE
TO PREVENT BACK FLOW TO PLATENS

ALL PLUMBING DOWNSTREAM
FROM THIS CONNECTION
ARE CUSTOMER SUPPLIED

SHEET 1 OF 2
845.00008A

TYPICAL COOLING CIRCUIT FOR SINGLE OPENING PRESS.
 TYPICAL AIR INSTALLATION @ 40% HUMIDITY AND 70 °F
 RUN FULL SIZE LINES OR BIGGER TO COMPONENTS

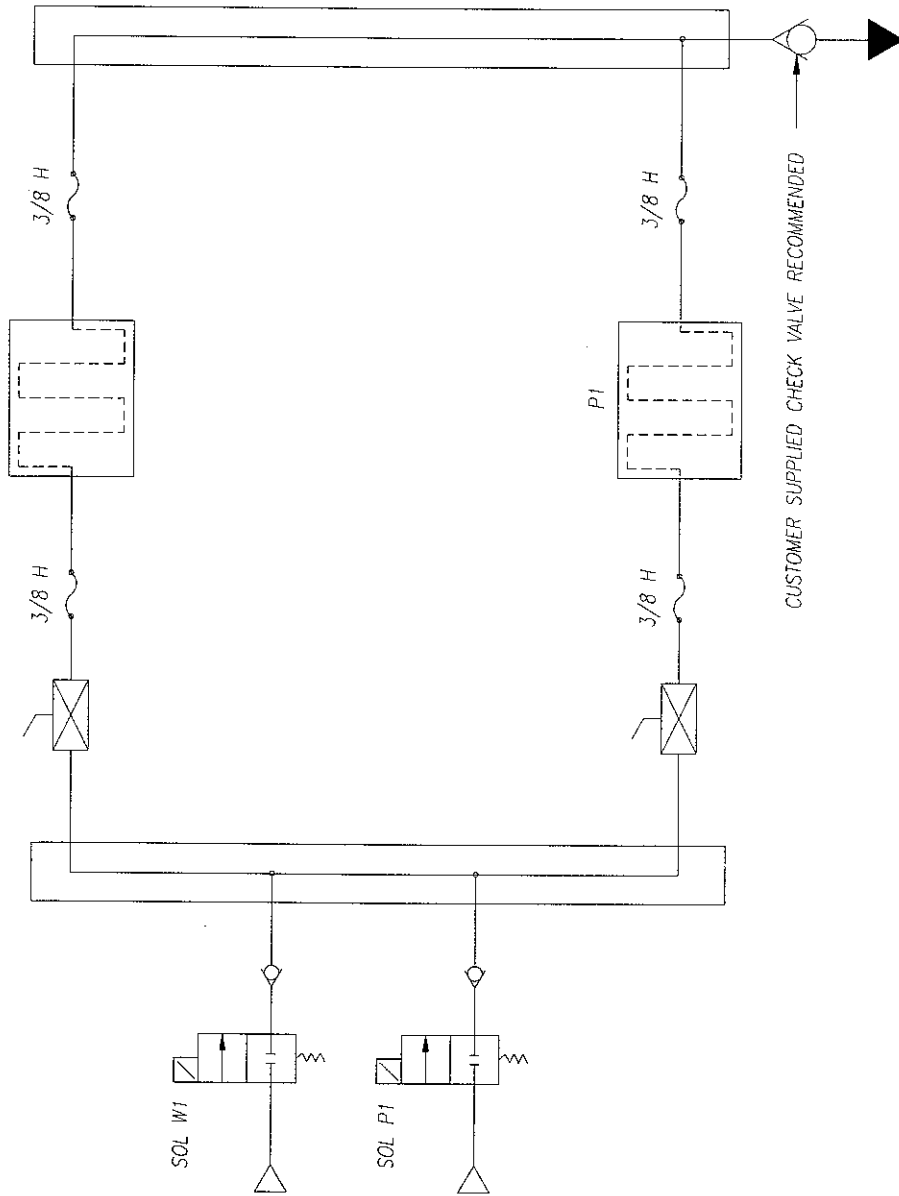

SUPPLY 5 GPM WATER @ 55° TO
 1/2" NPT SOL. VALVE

SUPPLY AIR @ 15-20 PSI LESS THAN
 WATER PSI TO 1/2" NPT SOL. VALVE.
 WITH A MINIMUM OF 20 PSI.
 APPROXIMATELY 0.5 SCFM OF AIR
 IS NEEDED FOR EACH COOLING CYCLE

CUSTOMER SUPPLIED CHECK VALVE RECOMMENDED

1" NPT DRAIN FOR
 PURGE FROM PLATENS
 USE ONLY STEEL PIPE
 SEE OPTIONAL DRAIN PLUMBING ON PAGE 1

3.9 HYDRAULIC OIL & LUBRICATION

The lubrication points, types of lubricants, and lubrication services required are listed below in Table 3-1. Refer to the **WABASH MPI** lubrication specifications at the end of this section for a listing of approved products for your machine. Use only new or refined, properly formulated oil in this machine. **Do not use recycled oil.** Turn off main disconnect switch before performing any maintenance or lubrication work.

IMPORTANT: All hydraulic oil should be pre-filtered to 10 microns before it is added to the system.

LUBRICATION POINT	LUBRICATION SERVICE
Oil reservoir	Fill oil reservoir through fill port on top of tank. Using an auxiliary filter unit with 10 micron filter is recommended. Fill tank with filtered oil until the oil level is approximately 3/4 of the way up on the sight gauge.
Electric motor	Two shots of grease.
Moving platen	After wiping away old grease from guide rods add grease until fresh grease is seen.

Table 3-1: Initial Lubrication

NOTE: Do not use high temperature grease on guide rods, damage to bushings may occur.

3.10 LUBRICANT SPECIFICATIONS AND SUPPLIES

The following provides specifications and supplier information for each type of lubricant needed for your machine.

3.11 GREASE

Any premium quality multipurpose grease is recommended for proper lubrication. The following products are suggested for use with this machine.

RECOMMENDED GREASE

SUPPLIER

PRODUCT NAME

Chevron Rykon Premium Grease EP
 Shell Alvania®EP-2
 Phillips Philube Polytac™EP-2
 Marathon Maratech®HDP

The following products are suggested for use with this machine when you need to use food grade grease instead of conventional grease. Therefore, it is strongly recommended that these products not be mixed.

WABASH MPI does not certify the food grade nature of these greases. Contact the fluid manufacturer for certification of properties.

RECOMMENDED FOOD GRADE GREASE

SUPPLIER

PRODUCT NAME

Fiske Brothers Lubriplate ACL Series
 JAX Industrial Lubricants JAX Magna-Plate 36 Series
 Kluber Lubricating Corp. Paraliq GA 531 (NLGI #1.5 only)
 Master Lubricants Lubriko CW-606-B (NLGI #2 only)
 Witco Chemical Aluminum Complex EP2 Food
 Machinery Grease (NLGI #2)

3.12 FILLING THE OIL RESERVOIR

The oil reservoir should be filled with of hydraulic oil as specified below. Oil should be pumped through a filter cart with a **10 micron absolute** filter element. **Do not** pour oil directly into the reservoir. After start-up, check oil level and add oil to full mark on oil level gauge if required.

STANDARD MODEL	APPROXIMATE OIL CAPACITY
G15 & G30	15 gallons
G50	20 gallons
G100	45 gallons
G150	60 gallons

NOTE: Presses equipped with special options, ie faster speeds, may require larger oil reservoirs.

3.13 RECOMMENDED HYDRAULIC OIL

A premium grade of mineral base, high pressure, hydraulic oil with anti-wear and anti-foaming additives with an ISO viscosity rating of 46 cSt (Centistokes) at 40°C (100°F) and a viscosity index of 90+ with equivalent or greater specification of the oil listed below, can be used, provided it is filtered through a 10 micron absolute filter, prior to being added to the hydraulic reservoir.

WARNING: If oil is not filtered through a **10 MICRON ABSOLUTE FILTER** before being placed into the hydraulic reservoir, the **WARRANTY MAY BE VOID.**

IMPORTANT: Do not use fire retardant ester based oils, transmission fluid, brake fluid, or water-glycol mixes.

Always add clean oil to the reservoir from a clean container through a 10 Micron absolute filter.

WARNING: If oil is not filtered through a **10 MICRON ABSOLUTE FILTER** before being placed into the hydraulic reservoir, the **WARRANTY MAY BE VOID.**

RECOMMENDED HYDRAULIC OIL

SUPPLIER

PRODUCT NAME

Exxon	NUTO H46
Gulf	Harmony 46AW
Kendall	Kenoil 051
Amoco	Rykon 46R or Amoco AW46
Shell	Tellus 46
Mobil	DTE25

NOTE: The oil temperature must be maintained between 105°F and 120°F, connect the cooling if necessary, for the machine to operate properly.

3.14 CHECK FOR PROPER PUMP MOTOR ROTATION

Verify the motor is rotating properly by looking through the slot in the motor housing at the direction of the cooling fan rotation. If the motor is rotating improperly, reverse any two wires at the disconnect.

IMPORTANT: DO NOT reverse the wires at the motor starter.

3.15 MACHINE SPECIFICATIONS

Std Model	Heated Platen Model	Clamp Force Tons (Kn)	Clamp Cyl. Bore in (mm)	Platen Size in (mm)	Tie Rod Dia. in (mm)	Daylight Std./Heated in (mm)	Stroke in (mm)	Approx. Weight (lbs.) (Kg)
G15-12	G15H-12	15 (134)	5 (127)	12x12 (305x305)	1.25 (32)	10-18 / 6-12 (254-457 / 152-305)	6 (152)	1650 (748)
G15-15	G15H-15	15 (134)	5 (127)	15x15 (134x134)	1.25 (32)	10-18 / 6-12 (254-457 / 152-305)	6 (152)	1750 (794)
G30-12	G30H-15	30 (267)	5 (127)	12x12 (305x305)	1.25 (32)	10-18 / 6-12 (254-457 / 152-305)	6 (152)	1650 (748)
G30-15	G30H-15	30 (267)	5 (127)	15x15 (134x134)	1.25 (32)	10-18 / 6-12 (254-457 / 152-305)	6 (152)	1750 (794)
G30-18	G30H-18	30 (267)	5 (127)	18x18 (457x457)	1.25 (32)	10-18 / 6-12 (254-457 / 152-305)	6 (152)	3500 (1588)
G50-15	G50H-15	50 (445)	7 (178)	15x15 (134x134)	2 (51)	12-22 / 8-16 (305-558 / 203-406)	8 (203)	2000 (907)
G50-18	G50H-18	50 (445)	7 (178)	18x18 (457x457)	2 (51)	12-22 / 8-16 (305-558 / 203-406)	8 (203)	3500 (1588)
G50-24	G50H-24	50 (445)	7 (178)	24x24 (609x609)	2 (51)	12-22 / 8-16 (305-558 / 203-406)	8 (203)	4000 (1814)
G100-18	G100H-18	100 (890)	10 (254)	18x18 (457x457)	3 (76)	16-28 / 12-22 (406-711 / 305-558)	12 (305)	6000 (2722)
G100-24	G100H-24	100 (890)	10 (254)	24x24 (609x609)	3 (76)	16-28 / 12-22 (406-711 / 305-558)	12 (305)	6500 (2948)
G150-30	G150H-30	150 (1335)	12 (305)	30x30 (761x761)	3 (76)	16-28 / 12-22 (406-711 / 305-558)	12 (305)	10000 (4536)
ASTM Sample Preparation Presses								
N/A	G30H-ASTM	30 (267)	5 (127)	12x12 (305x305)	1.25 (32)	6-12 (125-305)	6 (152)	1850 (839)
N/A	G302H-ASTM	30 (267)	5 (127)	12x12 (305x305)	1.25 (32)	6-12 (125-305)	6 (152)	2150 (975)

3.16 EXHAUST GAS OR DUST REMOVAL

If the product you use in the press produces dust or gases that could be harmful to the operator, attach an exhaust system to the press. This can be done by either attaching the exhaust vent hood to the top of the guard, or by cutting a hole in the back of the guard and attaching the exhaust vent over the cutout. The cutout must be completely covered. The vent hood could also be mounted to the top bolster with flexible tubing, to allow for daylight adjustment. Airflow will then be drawn up, around the material, and out through the exhaust system.

4.1 OPERATOR SAFETY

When operating a **WABASH MPI** press, proper personal protective equipment should be worn at all times.

CAUTION: When using a press with heated platens, gauntlet gloves should be worn to protect the forearms and hands.

CAUTION: **WABASH MPI** recommends the use of safety glasses and guards while operating this equipment.

4.2 PRE START-UP CHECKS

1. Check that all auxiliary equipment (such as the hot oil unit, steam generator, or chiller) are ready for operation.
2. Check the electrical and mechanical connections. Verify the electrical supply is the correct voltage, phase and frequency.
3. Check that all optional safety shields are installed and gates are closed.
4. Check that there are no objects in the mold area.
5. Check that the reservoir oil level is correct.

4.3 OPERATOR CONTROLS

The following lists are an explanation of each pushbutton, pilot light and selector switch located on the operator panel.

1. "CONTROL POWER ON" - This is a green, illuminated pushbutton that, when pressed will energize the control circuit. When the control circuit is energized, this button will be illuminated.
2. "CONTROL POWER OFF" - This is a red pushbutton that when pressed will de-energize the control circuit.
3. "EMERGENCY STOP" - This over sized, maintained push/pull button is used to terminate machine operation in the event of an emergency.

4. "HYDRAULIC PUMP ENABLE" - This is a green, illuminated pushbutton that when pressed will energize the hydraulic pump motor circuit.
5. "HYDRAULIC PUMP OFF" - This is a red pushbutton that, when pressed will disable the hydraulic pump motor.
6. "PLATEN HEAT ON" - This green, illuminated pushbutton, when pressed will energize the heat circuit. When the heat circuit is energized, this button will be illuminated.
7. "PLATEN HEAT OFF" - This is a red pushbutton that, when pressed will de-energize the heat circuit.
8. REHEAT "MANUAL - AUTOMATIC" - This is a two position selector switch that is used to select either the manual or automatic mode of platen heat-up after a cooling cycle.
9. "AIR" - This is a white, illuminated push/pull button that, when pulled out, will activate the air circuit for cooling, when required. When the air circuit is energized, this button will be illuminated.
10. "WATER" - This is a blue, illuminated push/pull button that, when pulled out, will activate the water circuit for cooling, when required. When the water circuit is energized, this button will be illuminated.
11. MODE "MANUAL - SEMIAUTOMATIC" - This is a two position selector switch that selects the mode of operation of the press. "MANUAL" mode allows the press to operate by manual initiation of the controls. "SEMIAUTOMATIC" mode allows the press to operate with the operator entered values and requires the manual initiation of the closing of the press.
12. "CLOSE" - This is a black pushbutton that works in conjunction with item 13 Pressing and holding these two buttons simultaneously will close the press. Releasing one or both of these buttons before the "CLAMP SEALED" pilot light illuminates, will stop the closing of the press.
13. "CLOSE" - Same as item 12.
14. "CLAMP SEALED" - This is a white pilot light that indicates the clamp is closed and under pressure. The operator can release the "CLOSE" buttons when this light illuminates.
15. "OPEN" - This is a yellow mushroom head pushbutton that, when pressed, in the "SEMIAUTOMATIC" mode of operation, will open the press. When the press is in the "MANUAL" mode of operation this button must be

pressed and held to open the press. Releasing the button at any point before the full open position is reached will stop the opening of the press.

4.4 START-UP

After the pre start-up checks in Section 4-2 have been completed, perform the following steps to start-up the press.

1. Close guard door.
2. Turn on the water supply.
3. Turn on the compressed air supply. Set the air pressure regulator below the water pressure.
4. Turn on (close) the disconnect switch.
5. Press the "CONTROL POWER ON" pushbutton.
6. Press "HYDRAULIC PUMP ENABLE" push button to energize the hydraulic motor circuit, then press and release both "CLAMP CLOSE" push button quickly. The motor should spin, confirm proper motor rotation by observing, the direction of the cooling fan rotation, through the slots in the motor housing. There is a directional arrow on the motor housing to indicate proper rotation. If motor is rotating improperly, reverse any two wires at the disconnect.

IMPORTANT: DO NOT reverse the wires on the motor starter.

IMPORTANT: The hydraulic pump can be damaged if the motor is running in the wrong direction.

4.5 SHUT DOWN

1. Press the "CONTROL POWER OFF" pushbutton.

For maintenance or long-term shutdown, turn off (open) the disconnect switch and lock out. In addition, turn off the water and air supplies.

NOTICE: The "EMERGENCY STOP" pushbutton supplied on this press, will de-energize the control circuit, stopping all press movement. To restart the press, the button must be pulled out and the control power and pump turned back on. (See Section 4 -4).

4.6 MANUAL OPERATION

1. Close guard door.
2. Press "CONTROL POWER ON" pushbutton and it will illuminate.
3. Press the "HYDRAULIC PUMP ENABLE" pushbutton.
4. Select the "MANUAL" position of the "MAN/SEMIAUTO" selector switch.
5. Press the "PLATEN HEAT ON" pushbutton to energize the platen heat, it will illuminate.
6. Adjust the temperature controller to the desired setpoint. Refer to section 4-8 for controller information.
7. Close the clamp by simultaneously depressing and holding the dual "CLAMP CLOSE" push buttons. The clamp will close at a rapid speed until the "SLOWDOWN" proximity switch is actuated.
8. When the "SLOWDOWN" proximity switch is actuated, the "CLAMP SEALED" light illuminates, indicating that the operator may release the "CLAMP CLOSE" push buttons. The clamp will continue to build pressure to the setting of the panel mounted adjustable relief valve. The pump runs continuously to maintain this pressure setting.

If (Optional) platen cooling is required:

- A. Pull the "AIR" push/pull button to activate the "AIR COOLING" feature. This will energize the air solenoid valve and illuminate the "AIR" light. The heat relays will also be de-energized.

<p>WARNING: Do not use water cooling only, if platen temperature is above 350° (177° C). Air and water mix is to be used. Use only air cooling for temperatures above 650° F (343°). See section 3-7.</p>
--

- B. Pull the "WATER ON" push/pull button to activate the "WATER COOLING" feature. This will energize the water solenoid valve and illuminate the "WATER" light. The heat relays will also be de-energized.
- C. When the temperatures of all platens drop below 350° F (177° C), push the "AIR" push/pull button to turn the "AIR COOLING" off.

This will de-energize the air cooling solenoid valve and extinguish the "AIR" light.

- D. When the platen temperature drops to the desired level, push the "WATER" push/pull button to turn the "WATER COOLING" off. This will de-energize the water solenoid and extinguish the "WATER ON" light.

IMPORTANT: minimum of a 45 second air purge time is recommended after each cooling cycle to purge any residual water out of the platen cooling cores.

13. Open the clamp by depressing and holding the "CLAMP OPEN" pushbutton. The "CLAMPED SEALED" light will de-energize and the clamp will open until the pushbutton is released or the "CYCLE RESET" proximity switch is actuated.
14. When the "CYCLE RESET" proximity switch is actuated, the press is ready for another cycle.

4.7 SEMI AUTOMATIC OPERATION

1. Close guard door.
2. Press the "CONTROL POWER ON" pushbutton it will illuminate.
3. Press the "HYDRAULIC ENABLE ON" pushbutton.
4. Select the "SEMIAUTO" position of the "MAN/SEMIAUTO" selector switch.
5. Press the "PLATEN HEAT ON" pushbutton, it will illuminate.
6. Select the desired temperature setpoint on the temperature controllers. (Refer to section 4-8 information on the temperature controllers.)
7. Pull the "AIR" push/pull button (This should be energized if the platens are to be heated above 350°F [177°C]).

WARNING: Do not use water cooling only, if platen temperature is above 350° (177° C). Air and water mix is to be used. Use only air cooling for temperatures above 650° F (343°). See section 3-7.

8. Pull the "WATER ON" push/pull button.
9. Close the clamp by simultaneously depressing and holding the dual "CLAMP CLOSE" push buttons. The clamp will close at a rapid speed until the "SLOW DOWN" proximity switch is actuated.
10. When the "SLOW DOWN" proximity switch is actuated, the "CLAMP SEALED" light illuminates, indicating the operator may release the "CLAMP CLOSE" push buttons. The clamp will continue to close and build pressure.
11. When the "CURE TIME" expires, the programmed "WATER COOLING TIME" and "AIR COOLING TIME" begins. Also, the "WATER ON" and "AIR ON" lights illuminate, and the water and air solenoids energize to cool the platens with an air and water mist.
12. The "AIR COOLING TIME" should expire first, then the cooling switches to water only until the "WATER COOLING TIME" expires. At that time, the clamp will begin to open, the "CLAMP SEALED" light will de-energize and a blast of air will purge the residual water from the platen cores, after the water has shut off. The clamp will open until the "CYCLE RESET" proximity switch is actuated.

IMPORTANT: A minimum of a 45 second air purge time is recommended after each cooling cycle to purge any residual water out of the platen cooling cores.

13. When the "CYCLE RESET" proximity switch is actuated, the press is ready for another cycle.
14. When shutting the press down, de-energize the control circuit by pressing the "POWER OFF" pushbutton, the light will extinguish.

IMPORTANT: Momentarily pressing the "CLAMP OPEN" pushbutton at any time will interrupt the cycle and the clamp will open.

Any timed portion of the semiautomatic cycle can be eliminated by selecting the "OFF" setting of that function.

4.8 PLATEN REHEAT (Heated Platens only)

MANUAL REHEAT

1. Select the "MANUAL" position of the "REHEAT" selector switch.
2. Momentarily depress the "HEAT ON" pushbutton and it will illuminate and actuate the temperature controllers. Heat to each platen will cycle on and off individually as controlled by the temperature controller.
3. Adjust the temperature controllers to the desired setpoint. (Refer to section 4-8 for information on the controllers.)
4. When the "WATER" or "AIR" solenoids are energized, power is disrupted to the heat relay outputs of the temperature controllers.
5. When the clamp opens, the heat relays must be re-energized with the "HEAT ON" pushbutton before the next cycle.

AUTOMATIC REHEAT

1. Select the "AUTO" position of the "REHEAT" selector switch.
2. Momentarily depress the "HEAT ON" pushbutton, it will illuminate and activate the temperature controllers. Heat to each platen will cycle on and off individually as controlled by its temperature controller.
3. Adjust temperature controllers for desired setpoint. (Refer to section 4-8 for information on the controllers.)
4. When the "WATER" or "AIR" solenoids are energized, power is disrupted to the heat relay outputs of the temperature controllers. When the "WATER" or "AIR" solenoids are de-energized, power to the heat relay outputs resumes. The heat does not shut off when the press opens.

IMPORTANT: The heat may be shut off at any time by momentarily pressing the "HEAT OFF" pushbutton.

4.9 TEMPERATURE CONTROLLERS

Genesis Series Presses are equipped with one West 6100 series Digital Temperature Controller for each zone of Platen heat.

The controllers have self-tuning capabilities and auto/manual operation. The front panels are equipped with red light emitting diodes (LED) displays.

The controller operates in either of two modes: **User Mode** or **Set-Up Mode**. In the User Mode, the operator may adjust the setpoint value and monitor the controller outputs. In Set-Up Mode, all control parameters can be reviewed and adjusted. The controller front panel has a number of operator controls and indicators to serve the following functions.

Upper display: Comprises four digits with decimal points, displaying numbers from 9999 to -1999. Normally displays the value of the process variable. In Set-Up Mode, a setpoint and other control parameter values are displayed after selection by means of the front panel control keys.

Lower Display: Comprises four digits with decimal points or up to four alphabetic characters. Normally displays the setpoint value. In Set-Up Mode, it displays a legend which identifies the control parameters being viewed/adjusted.

LED Indicators: The front panel is equipped with five LEDs which indicate the various output states and Controller functions.

Controls: Four keys are provided for adjustment of the parameters and for selection of the Controller functions.

NOTE:	Please review the enclosed "West 6100 Controller Site Manual" for a complete description of their operation.
--------------	--

TEMPERATURE CONTROLLER SET-UP PARAMETERS

The control is set up and tested at the factory and the internal switches should not need to be adjusted. If a controller does not work properly, or you suspect someone has accidentally changed some settings, review the factory preset SET-UP parameters listed below. If any settings have changed, reset them to the factory preset values. If that does not work, contact the **WABASH MPI** Service Department at (260) 563-1184, EXT. 238 or 243 for assistance.

Proportional Band	2
Reset	2.48
Rate	.42
Setpoint High Limit	500°F
Setpoint Low Limit	32
Output Cycle Time	8

SETTING THE PROCESS CURE TEMPERATURE

1. Depress the "FUNCTION" key.
2. Adjust the setpoint value using the "RAISE" and "LOWER" keys.
3. When the desired setpoint is reached, press the "FUNCTION" key again to return to normal display mode.

SETTING THE HIGH TEMPERATURE ALARM

Please refer to the enclosed "West 6100 Controller Site Manual" for a complete description of the alarm functions of the temperature controllers.

PRE-TUNE OR AUTO-TUNE PROCEDURE

PRETUNE or AUTO-TUNE will automatically fine tune the internal control's PID process settings and should be selected whenever the process requirements change.

Disregard the controllers' initial response. The process temperature may vary above and below the setpoint for as many as three cycles before leveling off at the process setpoint. Auto-tuning can take up to 30 minutes, and should be done before any product is run through the press.

4.10 “OPERATOR INTERFACE” – AB “PANELVIEW 300 MICRO”

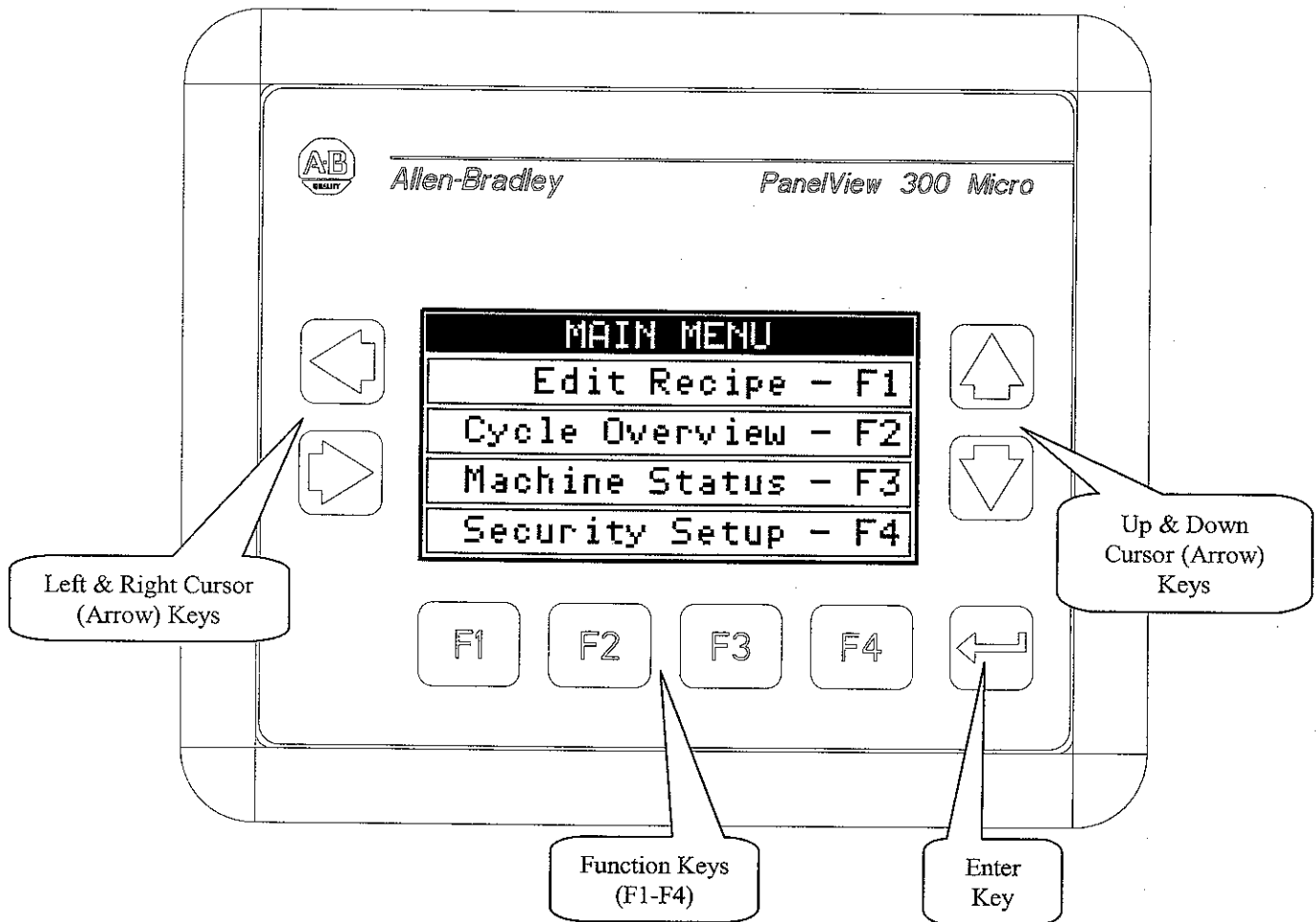

When the PanelView operator interface powers up, the MAIN MENU is displayed.

This screen has four selections,

- F1-Edit Recipe
- F2-Cycle Overview
- F3-Machine Status
- F4-Security Setup

To access the preset values for the cycle timers used during a semi-automatic cycle, push the F1-Edit Recipe function key and the first **EDIT RECIPE** screen will be displayed.

Selecting the F2-Cycle Overview function key will bring up the first **CYCLE OVERVIEW** screen. The **CYCLE OVERVIEW** screen is used to view the various cycle timers counting down during a semi-automatic cycle.

The F3-Machine Status function key will display the **MACHINE STATUS** menu. From this menu, the **PRODUCTION MONITOR** screen and the **PLC INPUTS** and **PLC OUTPUTS** screens can be accessed.

The **SECURITY SETUP** screen is displayed by pressing the F4-Security Setup function key. From the **SECURITY SETUP** screen the operator can login, logout and change the password.

Each of the four screen areas will be discussed in the following sections.

Note:

1. When entering a number on the PanelView for a timer setting, recipe number or password a numeric scratch pad is displayed. On the numeric scratch pad the Left/Right arrow buttons are used to move the cursor from one digit of the number to the next. The Up/Down arrow buttons are used to increase or decrease the value of that digit. When the number has been entered, press the Enter button. To exit the scratch pad without making any changes press the ESC (F1) button.
2. On the operator interface screens the F4 function key will always bring up the MAIN MENU unless the F4 key is labeled differently on a specific screen.

F1-EDIT RECIPE

The **EDIT RECIPE** screens are used to edit cycle timer values for the 10 recipes that the system stores. To select which recipe number to edit press the Left arrow button, enter a number between 1 and 10 on the numeric scratch pad and then press the enter button. Press the Next-F2 function key to move on to the next **EDIT RECIPE** screen. The remaining **EDIT RECIPE** screens are similar in form and function. The actual screens shown will be based on the options included with the machine. On these screens the various cycle timer values can be edited. Also the time base for the cycle timers can be individually selected to be in either seconds or minutes. To change a cycle timer value press the Left or Right arrow key accordingly. Enter the new value and press Enter. To toggle the time base for a cycle timer press either the Up or Down arrow key for the desired timer.

EDIT RECIPE 1
Recipe To Edit ##
Next-F2 Main-F4

The following is a listing of the various cycle timers that are used during a semi-automatic cycle. Included with the list are examples of the screens associated with the cycle timers. The first screen example explains the function of the various buttons on the Operator Interface.

Low Pressure Time ##### Seconds/Minutes – This timer, adjustable from 0 to 9999 seconds or minutes, starts when the clamp sealed light illuminates. During this time the low pressure light will be illuminated and the clamp will maintain the low pressure force setting.

High Pressure Time ##### Seconds/Minutes - This timer, adjustable from 0 to 9999 seconds or minutes, starts when the low pressure time expires or when the clamp sealed light illuminates if low pressure is not selected. During this time the high pressure light will be illuminated and the clamp will maintain the high pressure force setting.

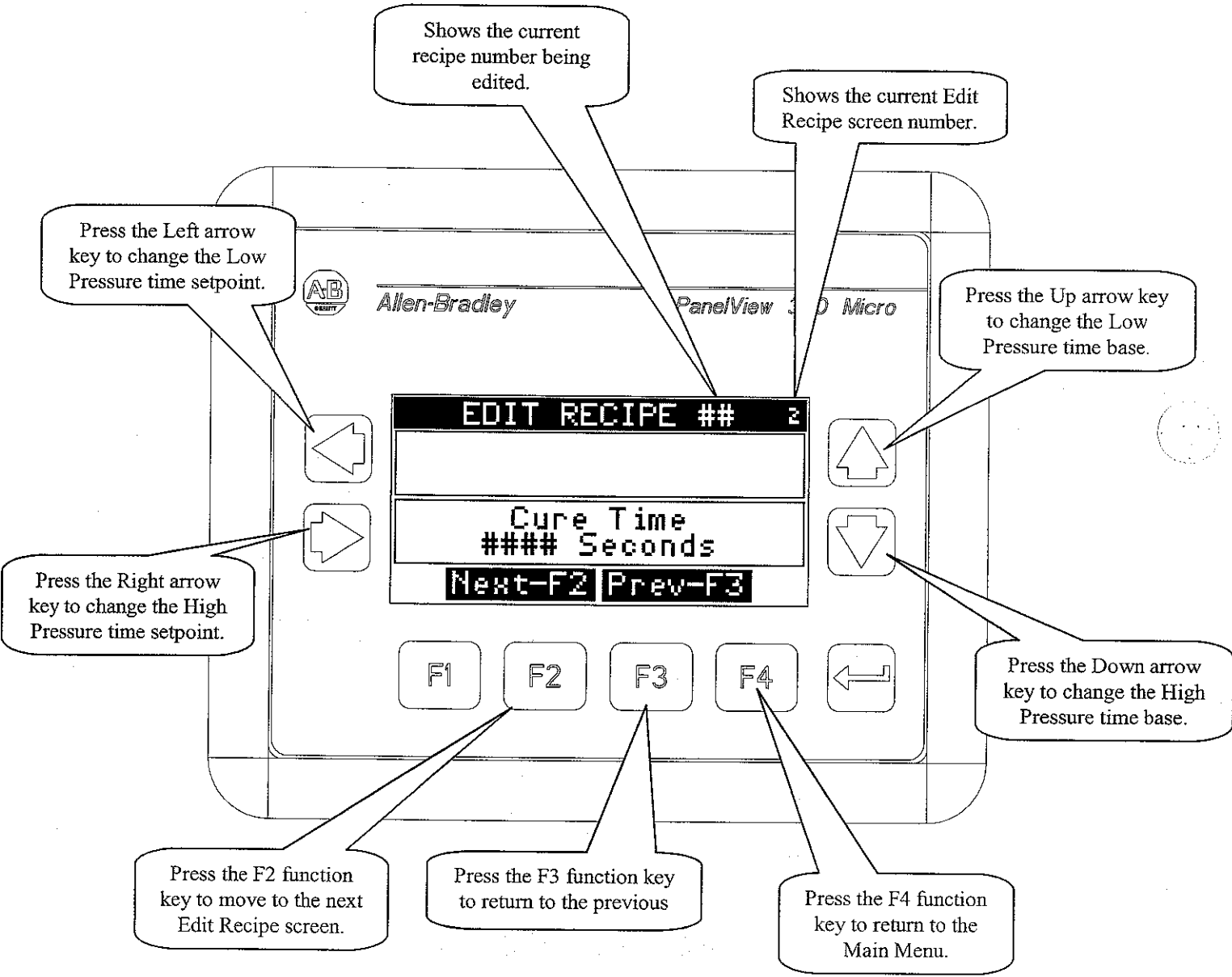

Cure Time ##### Seconds/Minutes - This timer, adjustable from 0 to 9999 seconds or minutes, starts when the clamp reaches the slowdown proximity switch and the clamp sealed light illuminates. During this time the clamp will maintain the clamp pressure force setting.

EDIT RECIPE ## 2
Cure Time ##### Seconds
Next-F2 Prev-F3

Air Cooling Time ##### Seconds/Minutes - This timer, adjustable from 0 to 9999 seconds or minutes, starts when the low pressure and/or the high pressure (cure time) timer(s) are complete. During this time the Air light will be illuminated and the air solenoid will be energized.

Water Cooling Time ##### Second/Minutes - This timer, adjustable from 0 to 9999 seconds or minutes, starts when the low pressure and/or the high pressure (cure time) timer(s) are complete. During this time the Water light will be illuminated and the water solenoid will be energized.

EDIT RECIPE ## 5
Air Cooling Time ##### Minutes
Water Cooling Time ##### Minutes
Prev-F3

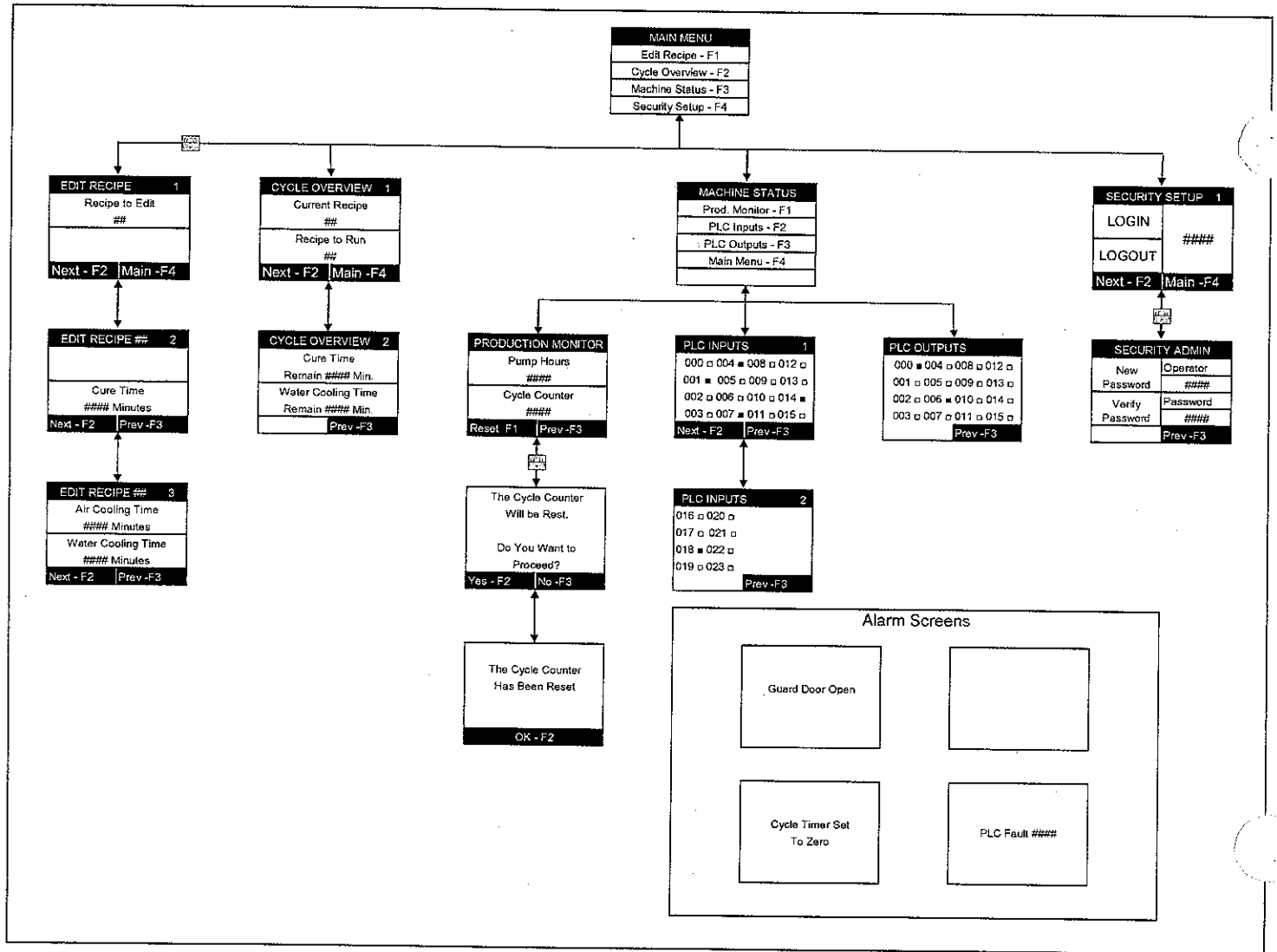

F2-CYCLE OVERVIEW

The **CYCLE OVERVIEW** screens are used to select which recipe number to run during a semi-automatic cycle and to view the cycle timers while a cycle is in process. Press the F2 function key on the **MAIN MENU** to access the first **CYCLE OVERVIEW** screen. This screen has a display showing the current recipe number and a numeric entry where the recipe number to run can be entered. To enter a recipe to run, press the down arrow key and enter the recipe number. When the press is open and the reset proximity switch is made the recipe to run becomes the current recipe.

Press the Next-F2 button to view the second cycle overview screen. On this screen the various cycle timers will be displayed while they are running. The displays will automatically change during the cycle.

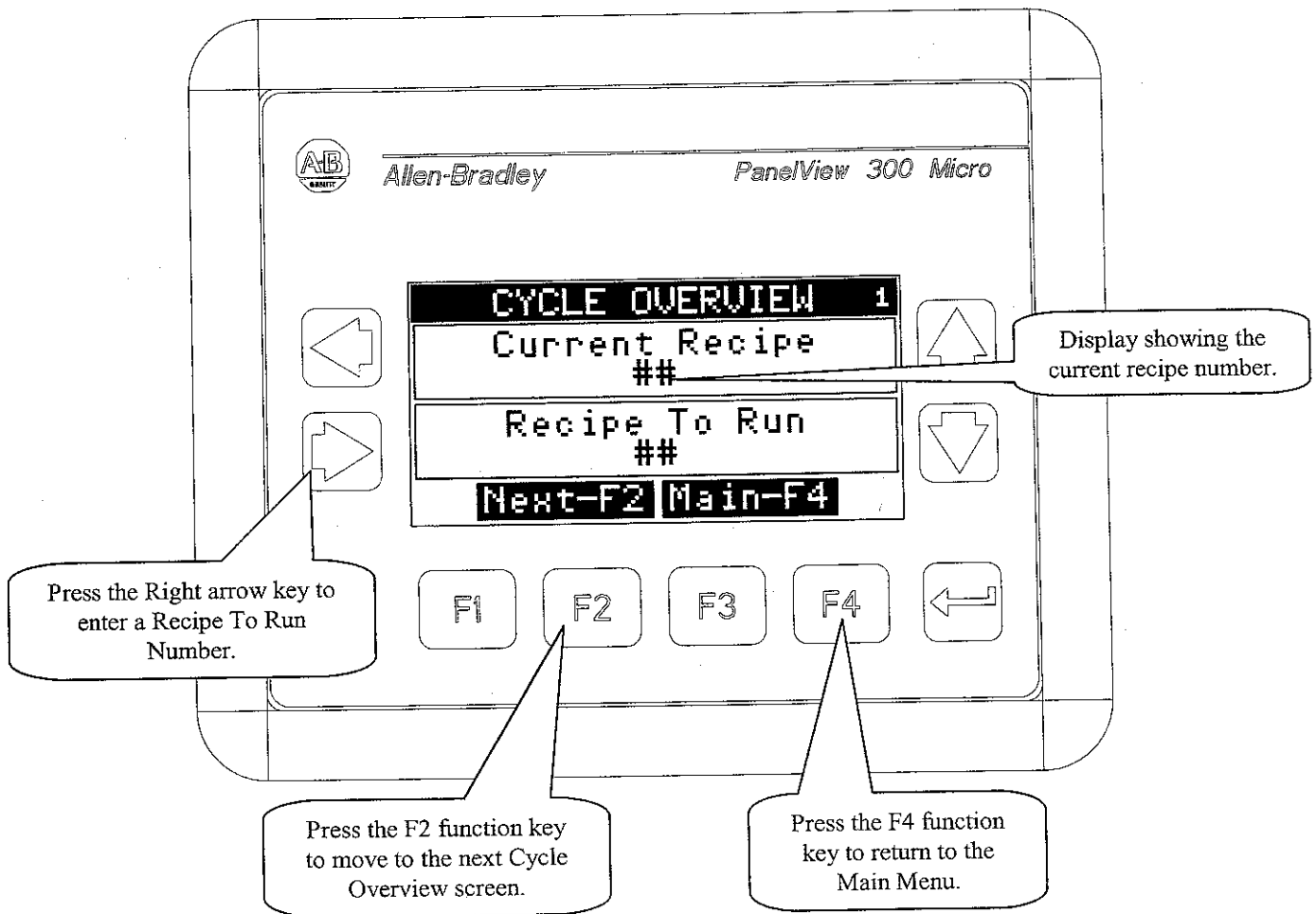

F3-MACHINE STATUS

The **MACHINE STATUS** menu allows access to the **PRODUCTION MONITOR** screen, the **PLC INPUTS** screens and the **PLC OUTPUTS** screen. Press the F3 function key on the **MAIN MENU** to access the **MACHINE STATUS** menu.

MACHINE STATUS
Prod. Monitor - F1
PLC Inputs - F2
PLC Outputs - F3
Main Menu - F4

The **PRODUCTION MONITOR** screen is displayed by pressing the F1 function key on the **MACHINE STATUS** menu. The **PRODUCTION MONITOR** screen shows the total number of hours the hydraulic pump motor has been running and the number of semi-automatic cycles that have been completed. Before the cycle counter can be reset a valid password has to be entered to unlock the reset function. To reset the cycle counter press the F1 function key. A screen will be displayed with the message "The Cycle Counter Will Be Reset. Do You Want To Proceed?" To confirm the cycle counter reset, press the Yes-F2 function key. A display with the message "The Cycle Counter Has Been Reset." will be displayed. Press the Ok-F2 function key to return to the **PRODUCTION MONITOR** screen. If you do not want to reset the cycle counter press the No-F3 function key and the **PRODUCTION MONITOR** screen will be displayed again without cycle counter getting reset.

PRODUCTION MONITOR
Pump Hours 0###0###
Cycle Counter #####
Reset-F1 Prev-F3

The Cycle Counter Will Be Reset. Do You Want To Proceed?
Yes-F2 No-F3

```

The Cycle Counter
Has Been Reset.

Ok-F2

```

The **PLC INPUTS** and **PLC OUTPUTS** screens display the status for each I/O point in the system. Each I/O point is labeled with a slot number and an address number. The first digit of the label shows the slot number. The base PLC I/O points are in slot 0. If any expansion I/O modules are used the first digit of the label corresponds to the slot location of the respective I/O module. The last two digits of the I/O point label denotes the I/O point.

To view the status of the PLC inputs press the F2 function key from the **MACHINE STATUS** menu. This will display the first **PLC INPUTS** screen.

```

PLC INPUTS 1
000  004  008  012 
001  005  009  013 
002  006  010  014 
003  007  011  015 
Next-F2 Prev-F3

```

```

PLC INPUTS 2
016  020 
017  021 
018  022 
019  023 
Prev-F3

```

To view the status of the PLC outputs press the F3 function key from the **MACHINE STATUS** menu. This will display the **PLC OUTPUTS** screen.

```

PLC OUTPUTS 1
000  004  008  012 
001  005  009  013 
002  006  010  014 
003  007  011  015 
Prev-F3

```

F4-SECURITY SETUP

Screen security is used on the operator interface screens to secure the **EDIT RECIPE** screens, the **SECURITY ADMIN** screen and the cycle counter reset function. A valid password will need to be entered before the secured screens and functions are accessible. There are two ways for an operator to login. The password entry screen will be automatically displayed when attempting to gain access to a secured screen. After a valid password has been entered the secured screen will be displayed. At this point the screens are unlocked and all the secured screens can be accessed without re-entering a password. The screens will automatically be locked out anytime the PanelView goes into screen saver mode or the logout button is pressed.

The second way to login and unlock the secured screens is to go to the **SECURITY SETUP** screen and press the Login button. Press the F4-Security Setup function key from the **MAIN MENU** to display the **SECURITY SETUP** screen. This screen has a Login and a Logout button on it, as well as a display showing the current security status (Locked or Unlocked). To login, press the left arrow button. This will display the password entry screen. Enter a valid password and press the enter button. The security status display will now say Unlocked. To logout, press the right arrow button. The security status display will then change to locked.

If an incorrect password is entered, a message will be displayed on the interface that says "Access denied. Press Any Key...". Press a key to make the message disappear.

To change the password, press the Next-F2 function key on the **SECURITY SETUP** screen. If the screens are currently locked the current password will need to be entered. After the password is entered the **SECURITY ADMIN** screen will be displayed. On this screen there is a **New Password** button, a **Verify Password** button, a current operator name button and a current operator password display. To change the password, press the up arrow button until the Operator display shows Unlocked. The current password is shown in the Password display. Next push the left arrow button to enter a new password. Enter the new password on the numeric entry screen and press enter. A message will be displayed that says "Please verify new password. Press Any Key..." Press a key and the **SECURITY ADMIN** screen is displayed again. Press the right arrow key and enter the new password again. A message will be displayed that says "Password changed. Press Any Key...". Press a key and the display will return to the **SECURITY ADMIN** screen.

Note: The default password is "1".

SECURITY ADMIN. 2	
New Password	Operator #####
Verify Password	Password #####
Prev-F3	

SECURITY SETUP 1	
Login	#####
Logout	#####
Next-F2 Main-F4	

ALARMS

The alarm banner will be displayed on the operator interface when an alarm condition becomes active. The banner will automatically disappear when the alarm condition no longer exists. The following is a list of the alarms and an example of the alarm banner associated with them.

Guard Door Open – This alarm is displayed when the guard door is open and the clamp is attempting to move. Make sure the guard door is closed before attempting to move the clamp.

Guard Door Open

Cycle Timer(s) Set To Zero – This alarm is displayed when a semi-automatic cycle is started and all of the active cycle timers (low pressure, high pressure, air cooling, water cooling) are set at zero. Make sure the selected recipe to run has cycle timer setpoints greater than zero before starting a semi-automatic cycle.

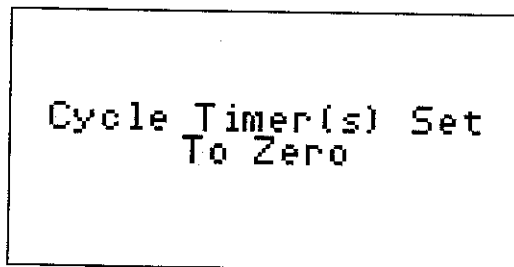

Cycle Timer(s) Set
To Zero

PLC Fault ##### - This alarm is displayed if the MicroLogix 1200 has a fault. The alarm screen will display the PLC Fault code. Consult the factory.

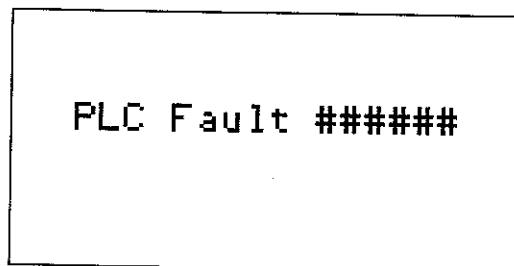

PLC Fault #####

4.11 “SLOW DOWN” AND “RESET” SWITCH ADJUSTMENT

Adjust the “RESET” proximity switch with the clamp fully retracted “OPEN”. Slide the switch until the light on the proximity switch is illuminated.

Adjust the “SLOWDOWN” proximity switch by following the same procedure. Position the “SLOWDOWN” proximity switch at the location where the slowdown sequence is to begin, typically 1/8” before mold contact is made.

5.1 SERVICING THE HYDRAULIC SYSTEM

CAUTION: Remove hydraulic pressure from system before loosening any hydraulic fittings.

IMPORTANT: Operating the press without filters installed will void the warranty.

IMPORTANT: Filter cleaning or replacement is an important part of press maintenance.

WABASH MPI Genesis Series Presses are equipped with a 100 mesh filter on the suction lines. These filters protect the pumps from contamination. Regular filter cleaning and/or replacement will keep your press operating at peak efficiency.

The filter is located in the hydraulic oil reservoir.

To clean the filter

- A. Open the press so the system is not under pressure.
- B. Turn off and lock out electrical power to the press.
- C. Drain the oil reservoir. Dispose of the contaminated oil following local and federal regulations.
- D. Loosen the clean-out door and remove it from the reservoir.
- E. Remove the filter element.
- F. Replace the filter if it is worn or cannot be cleaned. Empty any fines that may have collected on the filter element.
- G. Install the cleaned (or new) filter on the suction line.
- H. Replace and secure the clean-out door.
- I. Refill the oil reservoir with clean hydraulic oil pumped through a filter cart. (See Section 3-12)
- J. Jog the pump until primed. You may need to loosen a fitting on the outlet of the pump to bleed the air out of the system.

5.2 SYMPTOMS OF CONTAMINATED HYDRAULIC OIL

The hydraulic oil required for use in the **WABASH** press, like all hydraulic oils, degrades after an indefinite period of time. Useful life depends on variables such as moisture content, contamination, and operating conditions.

Your **WABASH** press may need new hydraulic oil if it exhibits any of the following symptoms:

- Elevated oil temperature with recommended cooling in operation.
- Milky color rather than clear.
- Burnt odor.

5.3 HEATER REPLACEMENT (WHERE APPLICABLE)

WARNING: Disconnect all power to the press before service.

1. DISCONNECT ALL POWER TO THE PRESS. "LOCK OUT" and "TAG OFF" the main breaker to the press.
2. Remove the thermocouple(s) from the adapter on the back of the platen and move away from the heater box.
3. Remove the heater box cover or complete heater box (whichever type is installed) from the back of the platen.
4. Locate the burned-out heater elements, and disconnect the wires.

IMPORTANT: Mark the wiring as necessary to ensure exact replacement to prevent heater imbalance.

5. Pull heater elements straight out the back of the platen. Some force will be required as heaters are peened in place at installation.
6. Before installing new heater elements, make sure to round out the heater hole with a file or reamer until the new heater slides easily into place.
7. Add a high temperature anti-seize compound on the new heater(s) and insert until
8. 1/4" (6.5 mm) of the heater is protruding from the back of the platen. Push the heater in so that it is flush with back of the platen and peen it on place.

9. Rewire and retape the new heater(s). Use a high temperature electrical tape. We recommend 3-M #69 glass tape. Reverse items 1, 2 and 3.

NOTE: Use only high temperature wire and electrical connectors if required.

WARNING: If your press is equipped with a door in the guard, and the door requires a tool to be opened it is for maintenance purposes only. The press is not to be run with this door open.

5.4 PLATEN DAYLIGHT ADJUSTMENT

CHANGING DAYLIGHT (DISTANCE BETWEEN BOLSTERS OR PLATENS)

When necessary to level platens or change daylight:

- A. Loosen 5/16" Allen-head set screws (Fig. 1) in both the top and bottom nuts serving the top head plate. (Fig. 2)

FIG. 1

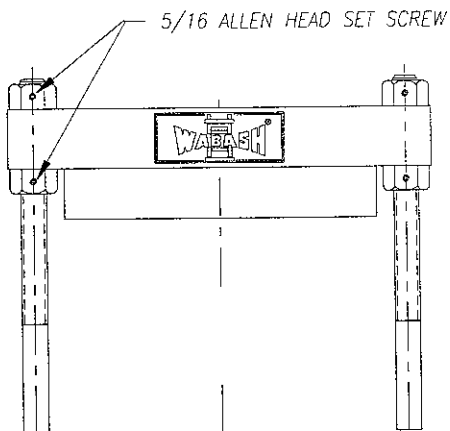
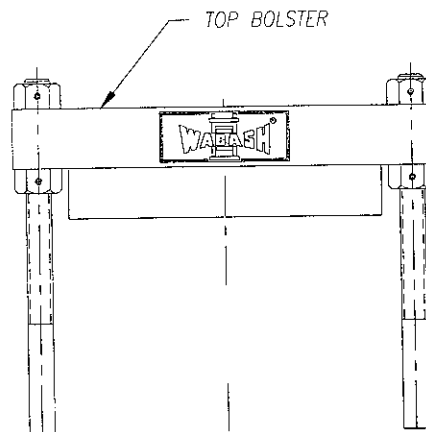
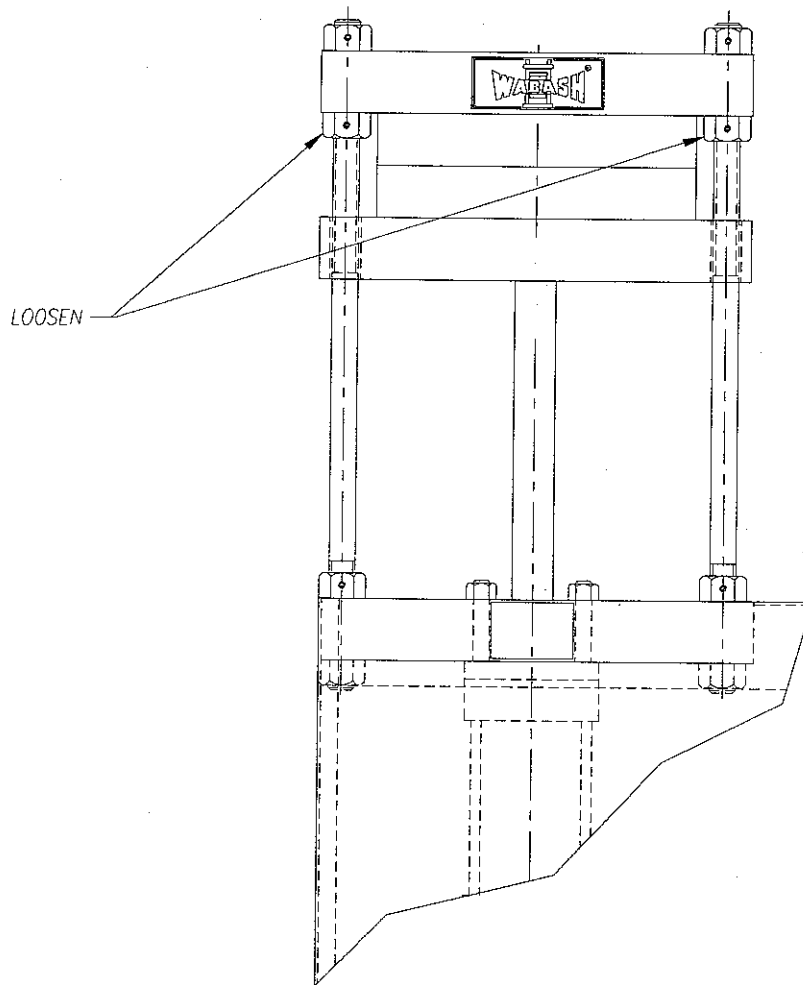

FIG. 2



- B. Close the press until the moving platen is touching the stationary platen. If the daylight is greater than the stroke, parallels will have to be used. (See Fig. 4)
- C. Set the relief valve, contact gauge or digital pressure setting to maximum press capacity, and close the press. Build pressure to the maximum setting.

FIG. 3



- D. The nuts on the bottom of the bolsters (Fig.3) will now be relieved of pressure and should be loosened by hand. (A wrench may be necessary to loosen the nuts.) Loosen the nut approximately 1/4" (6.5 mm). Relieve the hydraulic pressure until the top head is floating on the bottom platen. The platens are now parallel and none of the nuts should be touching the top head (Fig. 4).

FIG. 4

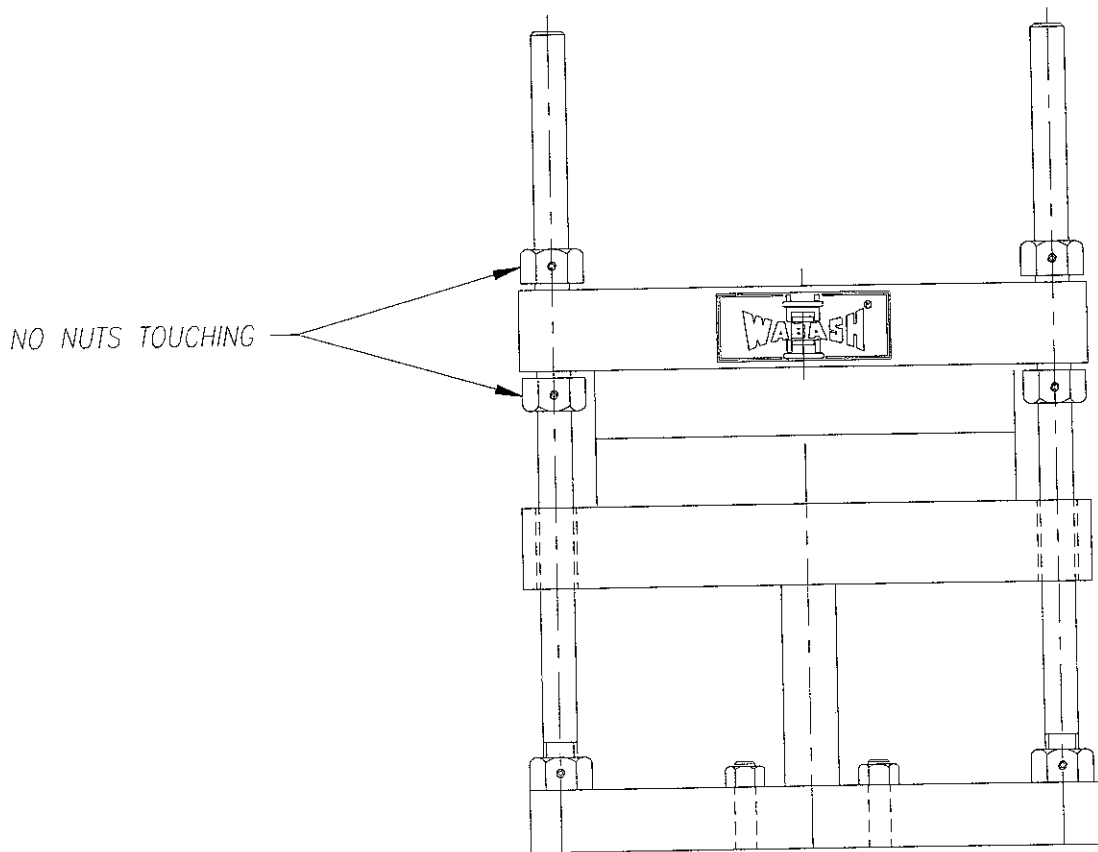

- E. Adjust the platens up or down as desired by positioning the hydraulic cylinder.
- F. When the stationary platen of the press is in the desired location, tighten the lower nuts evenly, using finger pressure only. (See Fig. 4)
- G. Evenly tighten the top nut finger tight and set the 5/16" Allen set screws so the large nuts will not turn.
- H. Close the press to full pressure and tighten the lower nuts finger tight. Tap a little tighter with a small hammer and secure the 5/16" Allen set screws. The press is now level and adjusted. Ensure that all set screws have been secured.

5.5 PLATEN PARALLELISM

EQUIPMENT REQUIRED:

- .125" (3mm) Solid Core Solder
- 1" (25mm) Micrometer
- Suitable sized wrench
- 5/32" Allen Wrench

CHECKING PRESS LEVEL

1. Platens are to be at room temperature.
2. Cut (9) strips of solder 1" (25mm) long.
3. Place the solder in the opening of the press. (In multi-opening presses, do one opening at a time.)
4. Solder should be placed approximately 2" (50mm) from the edge of the platen and one piece in the center.

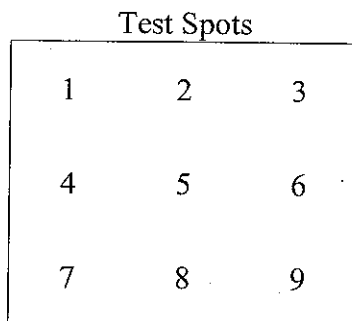

FRONT

Solder location

5. Close press and put approximately 15 or 30 tons (13 to 27 metric tons) depending on which model) of force on solder. (Maintain pressure for about 30 seconds)
6. Open the press.
7. Measure the thickness of the solder with a micrometer.
8. Solder should be compressed to approximately 2/3 of the original thickness for an accurate reading to be taken

<u>EXAMPLE:Reading</u>		
1. = .033 (.837mm)	4. = .033 (.837mm)	7. = .033 (.837mm)
2. = .033 (.837mm)	5. = .033 (.837mm)	8. = .034 (.862mm)
3. = .032 (.812mm)	6. = .034 (.862mm)	9. = .037 (.939mm)
Based on these findings, the front right corner of the top head will have to be lowered.		

9. If all four corners are within specifications and the platen is still not within specifications, the following changes will need to be made:

- Use shims to level the platens.
- Have platens resurfaced. The insulation board should be replaced anytime the platens are removed to be resurfaced.

NOTE: Heated platen mounting bolts must be checked regularly for proper torque specifications. The thermal expansion and contraction of the platens and bolts have allowed the bolts to loosen in some instances. Platen mounting bolts should be checked weekly when in a standard production cycle.

RECOMMENDED HEATED PLATEN BOLT TORQUE SPECIFICATIONS

<u>SCREW SIZE</u>	<u>TORQUE</u>
INCHES	FT-LBS
.375	15
.500	15
.625	25
.750	40

5.6 MOLD SIZE VERSUS TONNAGE CHART

Maximum tonnage allowed on different mold sizes before platen coining occurs.

MOLD SHAPE				MOLD AREA		MAXIMUM ALLOWABLE FORCE	
SQUARE		ROUND				TONS	
IN.	CM	IN.	CM	IN. ²	CM ²	U.S.	METRIC
		3	7.62	7.07	45.62	4.25	3.86
3	7.62			9.00	58.07	5.50	4.99
		4	10.16	12.56	81.04	7.50	6.80
4	10.16			16.00	103.23	9.60	8.71
		5	12.70	19.64	126.72	11.75	10.66
5	12.70			25.00	161.30	15.00	13.61
		6	15.24	28.27	182.40	17.00	15.42
6	15.24			36.00	232.27	21.60	19.59
		7	17.78	38.48	248.27	23.00	20.87
7	17.78			49.00	316.15	29.40	26.67
		8	20.32	50.27	324.34	30.15	27.35
8	20.32			64.00	412.93	38.40	34.84
		9	22.86	63.62	410.48	38.17	34.63
9	22.86			81.00	522.61	48.60	44.09
		10	25.40	78.54	506.74	47.12	42.75
10	25.40			100.00	645.20	60.00	54.43
		11	27.94	95.03	613.13	57.02	51.73
11	27.94			121.00	780.69	72.60	65.86
		12	30.48	113.13	729.91	67.85	61.55
12	30.48			144.00	929.09	86.40	78.38
		14	35.56	153.94	993.22	92.35	83.78
14	35.56			196.00	1264.59	117.60	106.68
		16	40.64	201.06	1297.24	120.60	109.40
16	40.64			256	1651.71	153.60	139.34
		18		254.47	1641.84	152.65	138.48
18	45.72		45.72	324	2090.45	194.40	176.35

5.7 RECOMMENDED SPARE PARTS

The following parts should be kept in stock to minimize downtime:

- Heater Contactor
- Fuses
- Cartridge Heater(s)
- Thermocouple
- Filters
- Proximity Switches
- Cylinder Rod Seals
- Hydraulic, Water, or Air Valve Solenoids
- Pushbutton or Pilot Light Bulbs

Please consult the drawing provided with the original information packet supplied at time of machine shipment for a complete description and part number.

The following is a list of websites for the major purchased components of the press. This is supplied for the purpose of helping trouble shooting and the correct identification of the replacement parts needed.

Allen Bradley: Controls - www.ab.com

Rexroth: Hydraulic pumps and valves - www.boschrexroth-us.com

Parker: Pneumatic cylinders - www.parker.com

Omron: Proximity switches - www.oeiweb.omron.com

West: Temperature controls - www.westinstruments.com

5.8 RECOMMENDED PREVENTIVE MAINTENANCE

1. Daily Maintenance Checks

- A. Clean platen surfaces of any foreign materials. Wipe with clean dry cloth.
- B. Check platen mounting bolts for tightness (180 in/lbs).
- C. Check for any hydraulic fluid or cooling water leakage.
- D. Check stress rod lubrication. (Do not over lubricate.)
- E. Check air line filters for water accumulation and drain if water is present.
- F. During platen heat up, at approximately 100-125°F use a hand held pyrometer to check for any HOT or COOL spots. HOT or COOL spots could indicate a bad heating element or water leaking by the valves into the platen. (If a HOT or COOL spot is detected, have Maintenance personnel check for a possible problem.)

2. Bi-Annual Inspections

A. PLATENS

- a. Check platen mounting bolts for tightness.
- b. Run solder test to check for flatness and parallelism. Clean all foreign material from platens before solder test is performed.
- c. Make proper adjustment if platens do not meet required specifications. (Refer to Section 5-5)
- d. Check for any leaks in the platen cooling system. (Replace cooling hoses with direct replacement.)

3. HEATERS

- A. Remove electrical power from press.
- B. Inspect heater wires and jumpers between heaters for broken or frayed leads.
- C. Repair or replace any broken or frayed wires.
- D. Use an ohmmeter to check all heaters for an open or short condition.
- E. Replace any defective heaters.

4. TEMPERATURE CONTROLLERS AND CONTACTORS

- A. Check that temperature controller is displaying the proper temperature.
- B. Check that temperature controller is controlling temperature at setpoint.
- C. Check contactor fuses.
- D. Check for the proper operation of the mercury tube on each contactor. (3 per contactor) Remove the wires from each end of the mercury tube, energize the coil on the mercury relay. Using an ohmmeter, check for continuity through the mercury tube. A properly operating mercury tube, should have very little resistance through the tube with the coil energized. (If a mercury relay is found to be defective and is replaced, dispose of the defective mercury relay following all local and federal regulations.)
- E. Check for any loose wires or connections at the contactor terminals.

5. THERMOCOUPLE

- A. Remove the thermocouple from the platen, clean the tip with steel wool.
- B. Check for loose or damaged wires and conduit.
- C. Replace thermocouple if there is any noticeable damage.

6. HYDRAULIC SYSTEM

- A. Check for any leakage of hydraulic fluid.
- B. Repair or replace any defective hydraulic component.
- C. Check hydraulic fluid level, which should be $\frac{3}{4}$ full on the sight glass.
- D. Replace (optional) high pressure or return line filter element. Refer to hydraulic circuit.
- E. Clean hydraulic heat exchanger water inlet screen. Refer to hydraulic circuit.

7. CLEANING OF THE PRESS

- A. Painted surfaces should be cleaned with a household cleaner.
- B. Non-painted surfaces should be kept clean and wiped down with a light coat of oil or grease.

8. ANNUAL INSPECTIONS

- A. Replace hydraulic fluid. Refer to sections 3-12 and 3-13.
- B. Clean the inside of the hydraulic reservoir.
- C. Clean or replace suction line screen.
- D. Calibrate the clamp pressure gauge. *
- E. Calibrate the platen temperature controllers. *

*This should be completed by a **WABASH MPI** service technician.

WABASH MPI PRESS PREVENTATIVE MAINTENANCE CHECK LIST

INSPECTION DATE: _____

Model # _____ Serial # _____

WEEKLY INSPECTION	WK 1	BY	WK 2	BY	WK 3	BY	WK 4	BY
Inspect all bushings for wear; replace if worn, grease weekly.								
Check all platen mounting bolts for proper tightness								
Check all mold mounting bolts for proper tightness								
Filter hydraulic oil with external filter cart.								

MONTHLY INSPECTION	Performed by	Date
Disconnect and lock out power. Check the heater element for continuity with an ohmmeter.		/ /
Check the temperature tracking with an external pyrometer.		/ /

YEARLY INSPECTION	Date of last Inspection	Next Scheduled Inspection
Replace hydraulic oil		
Calibrate Pressure Indicator*		
Level Platens*		

* Should be performed by WABASH MPI Service Technician.

6.1 PRESS WILL NOT CLOSE

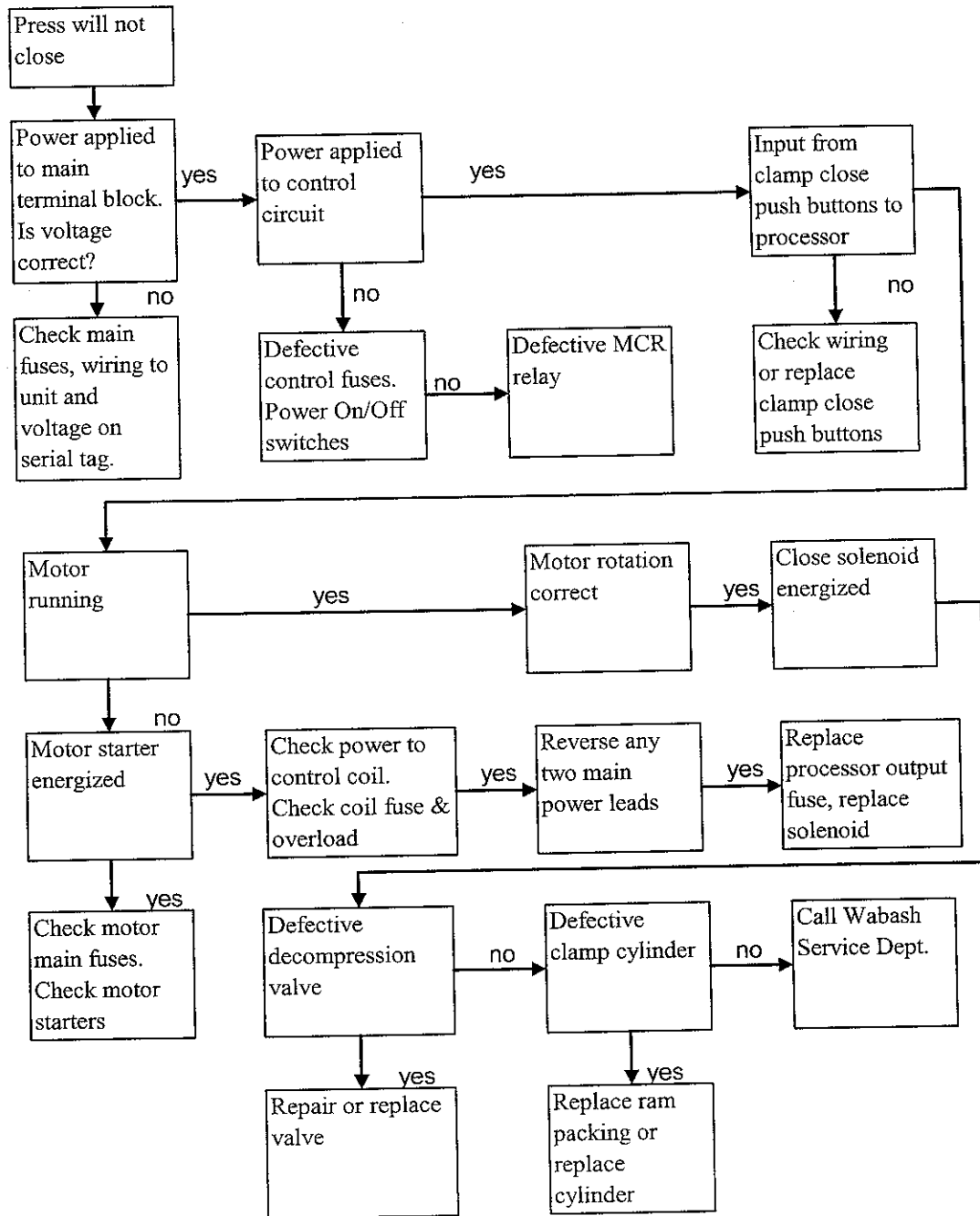

6.2 PRESS PLATENS WILL NOT HEAT

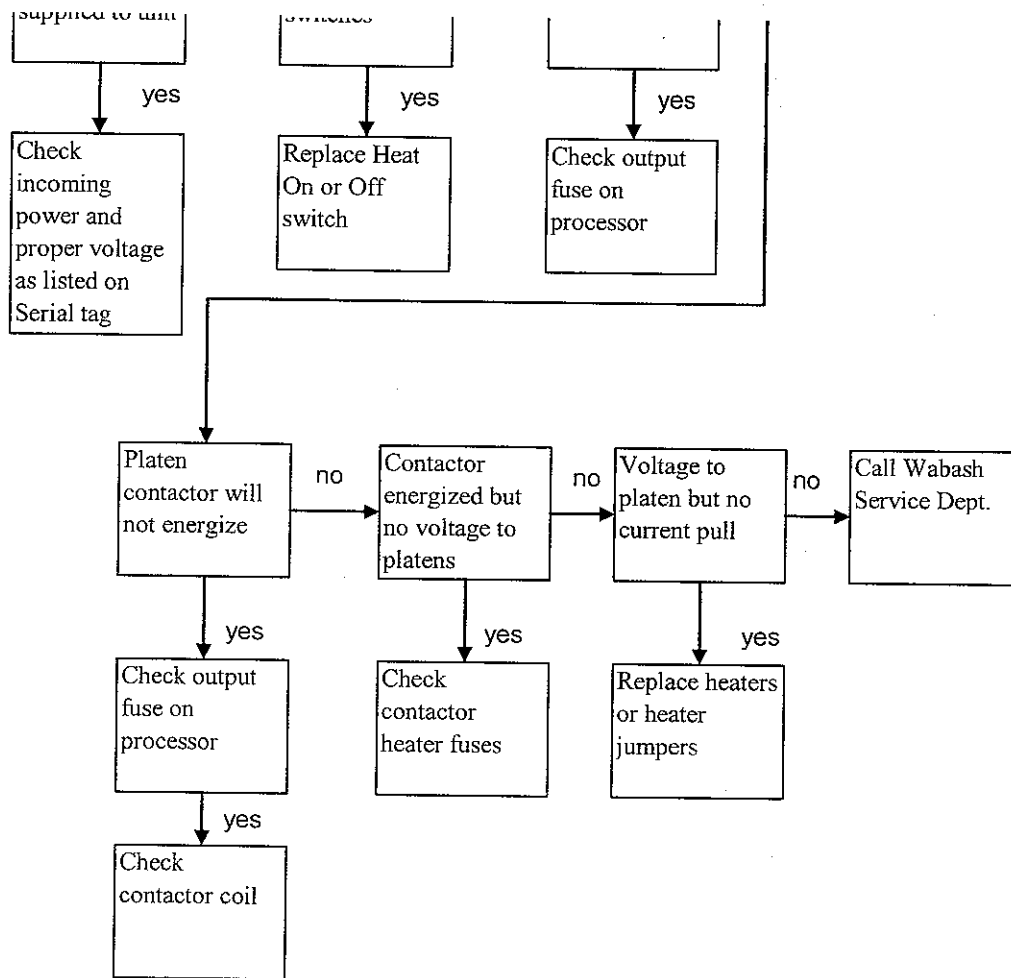

6.3 PRESS WILL NOT BUILD PRESSURE

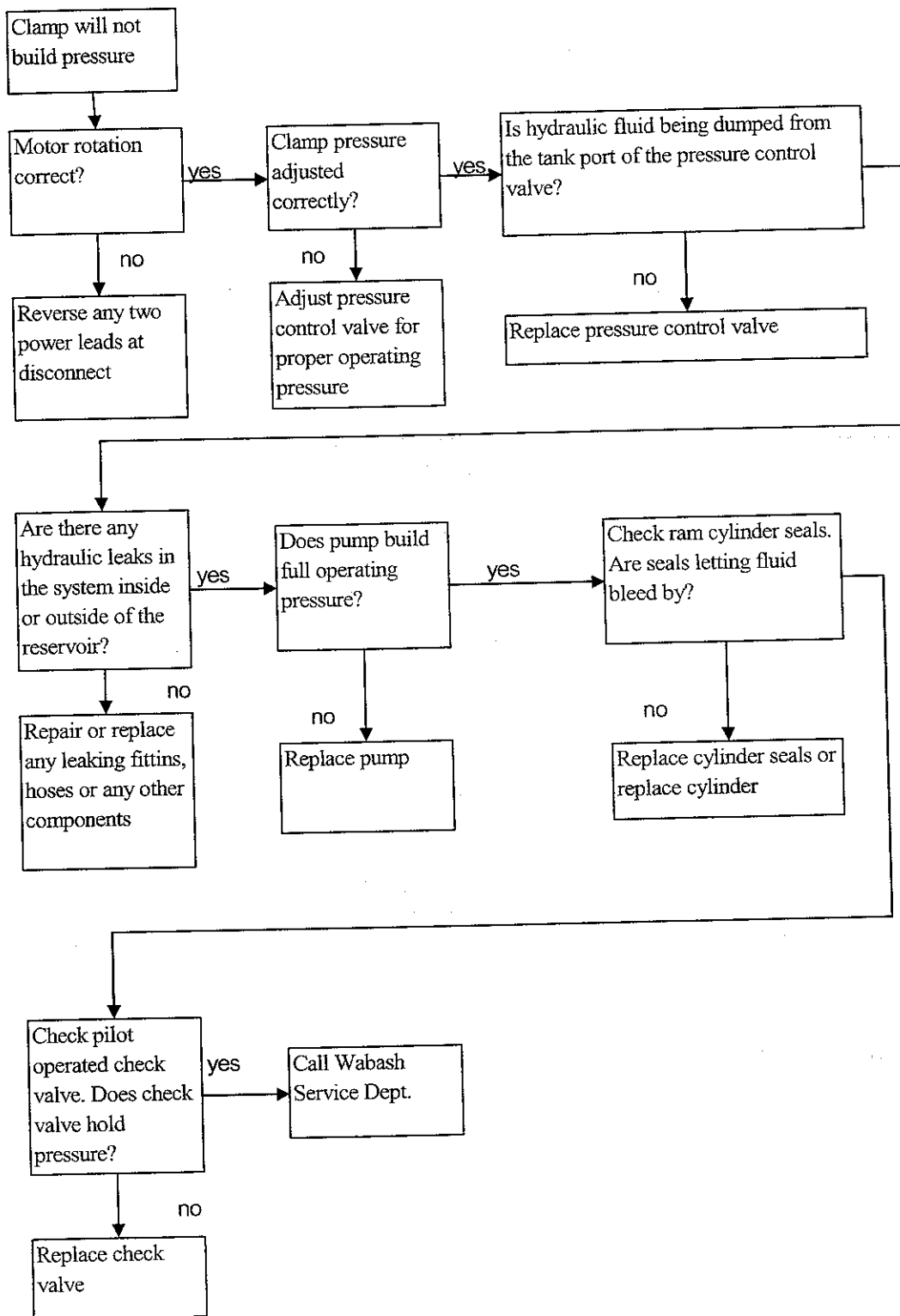

7.1 TECHNICAL ASSISTANCE**WABASH MPI PARTS DEPARTMENT**

Call from 7:30 a.m. to 4:30 p.m., Eastern Standard Time

(260) 563-1184, Extension 262

E-mail: wabashmpi@corpemail.com

The Parts Department at **WABASH MPI** is ready to provide the parts to keep your equipment up and running. Original replacement parts ensure operation at design specifications. Please have the model and serial number of your equipment available when you call. Consult the Parts List included in your information packet for replacement part numbers.

WABASH MPI SERVICE DEPARTMENT

Call from 7:30 a.m. to 4:30 p.m., Eastern Standard Time

(260) 563-1184, Extension 238 or 243

E-mail: wabashmpi@corpemail.com

WABASH MPI has a qualified Service Department ready to install, start-up, or service your press. Gauge calibration services are available. Contact Service Department for details. Yearly calibration and preventive maintenance by a **WABASH MPI** service technician is recommended.

WABASH MPI SALES DEPARTMENT

Call from 7:30 a.m. to 4:30 p.m., Eastern Standard Time

(260) 563-1184, Extension 230 or 233

E-mail, wabashmpi@corpemail.com

WABASH MPI products are sold through a worldwide network of independent sales representatives and distributors, as well as in-house sales personnel. Contact our Sales Department for the name of the sales representative or distributor nearest you.

7.2 RETURNED MATERIAL POLICY

1. Prior to the return of any material, authorization must be given by **WABASH MPI**. An RMA number will be assigned for the equipment to be returned.
2. A reason for requesting the return must be given.
3. All returned material purchased from **WABASH MPI** is subject to a 15% restocking charge.
4. All Returns are to be shipped prepaid.
5. The invoice number and date, or purchase order number and date must be supplied.
6. No credit will be issued for material that is not within the manufacturer's warranty period, and/or in new and unused condition, suitable for resale.

8.1 WARRANTY RETURNS

1. Prior to the return of any material, authorization must be given by **WABASH MPI**. An RMA number will be assigned for the part or equipment to be returned. All warranty returns require a Purchase Order.
2. Reason for requesting the return must be given.
3. All returns are to be shipped prepaid. Return freight, and replacement parts freight, are the responsibility of the customer.
4. The invoice number and date, or purchase order number and date, must be supplied.
5. After inspecting the material, a replacement or credit will be given at **WABASH'S** discretion, if the item is found to be defective in materials or workmanship and it was manufactured by **WABASH MPI**. Purchased components are covered under their specific warranty terms.

8.2 WARRANTY

WABASH MPI warrants all equipment we manufacture to be free from defects in workmanship and materials when used under recommended conditions. The Company's obligation under this warranty is limited to those parts which, within twelve (12) months from delivery of equipment to original purchaser, are returned to the factory with transportation prepaid, and upon examination shall be found to be defective.

WABASH MPI neither assumes, nor authorizes any other persons to assume any liability in connection with the sale of its equipment, except under the conditions of this warranty.

This warranty does not cover any labor charges for replacement of parts, adjustment, repair, or any other work done. This warranty shall not apply to any apparatus which, in our opinion, has been subjected to misuse, negligence, or pressures in excess of the limit recommended, or which shall have been repaired or altered outside of the factory.

Replacement of defective material(s) will be FOB from the **WABASH MPI** factory. Replacement of component parts not manufactured by **WABASH MPI** will be limited to the warranty of the manufacturer of such parts.

9.1 GLOSSARY OF TERMS

AIR PURGE: A timed cycle of air pressure used at the end of the cooling cycle or when the heat is turned on that purges (expels) any residual (left over) water left in the cooling cores of a platen after the cooling cycle.

BOLSTERS:

Base Bolster: The plate attached to the press frame that supports the clamp assembly.

Moving Bolster: The main moving press member that the platen or mold half is mounted to. (Normally actuated by the clamp cylinders.)

Top Bolster: The stationary press member that is mounted to the top of the stress/tie rods.

BUMP/BREATHE: An operation in the cycle when the clamp pressure is relieved for a short time period to vent trapped gases from the material and/or mold. This operation can occur multiple times when it is initiated.

CARTRIDGE HEATER: A cylindrical shaped electric resistive heating device that is typically inserted into drilled holes of a platen or mold.

CAUTION: A term used to indicate a potentially hazardous situation that, if not avoided, may result in minor or moderate injury.

CLAMP: The portion of the press that holds the two mold halves and opens and closes the mold.

CLOSING SPEED: The speed at which the clamp travels until making the slowdown position. Usually stated in inches per minute (IPM).

CONTACT GAUGE: A control feature that shuts the hydraulic system off at the manual setpoint of the gauge and restarts it if the pressure bleeds off.

COUNTERBALANCE SYSTEM: A system that provides for slowing, stopping or supporting, or any combination thereof, of a bolster and its attachments.

CURE TIME: The amount of time the press clamp stays closed and under pressure after making the slowdown position.

DANGER: A term used to indicate an imminently hazardous situation that, if not avoided, will result in death or serious injury.

DAYLIGHT: The distance between the platen or bolster work surfaces when the moving bolster is in its home or fully retracted position.

DOWN-ACTING CLAMP: A clamp assembly where the moving bolsters travels downward to apply pressure.

FLOATER: A bolster or platen assembly that is suspended in the clamp opening with cylinders or hanger rods to provide multiple daylights.

GUARD: A barrier or barriers which prevents entry of an individual's hand or other body part into the point of operation or other hazard area.

GUARD DOOR: An interlocked device arranged to enclose the point of operation.

HAZARD: A condition or set of circumstances that can cause physical harm to exposed personnel.

HANGER ROD: A steel rod used to suspend a floater to create multiple daylight.

IMPORTANT: A term used to emphasize areas where equipment damage could result, or provides additional information to make a step or procedure easier to understand.

INTERLOCK: An arrangement in which the operation of one control or mechanism automatically brings about or prevents the operation of another.

INTERLOCKED GUARD: A fixed or movable barrier attached and interlocked in such a manner that the press will not cycle or will not continue to cycle unless the guard itself or its hinged or movable sections enclose the hazardous area.

LIFTING POINT/HOLES: Threaded holes or drilled holes used for the sole purpose of lifting the press or one of its components.

MOLD AREA: The zone between the mold mounting surfaces of the press. This could be the zone between the platens if supplied, or the moving bolster and top or base bolster.

MOLD/DIE: The tooling used in a press for shearing, punching, forming, drawing, or assembling metal or other material.

NOTICE: A term used to indicate a statement of company policy directly or indirectly related to the safety of personnel or protection of property.

OPENING SPEED: The speed the clamp travels at when coming open. Usually stated in inches per minute (IPM).

OPERATOR: An individual who performs production work on the press or who controls the movement of the bolsters.

PLATEN: The plates attached to the moving and top bolsters of the press, they can be heated and or cooled, also they can have mounting provisions for the customers old/die.

POINT OF OPERATION: The location in the press where material is positioned and a process is performed.

PRESSING SPEED: The speed the clamp travels at after making the slowdown position. Usually stated in inches per minute (IPM) and considerably slower than closing speed. Sometimes called slowdown speed.

QUALIFIED PERSONNEL: One that is familiar with the construction and operation of the equipment or process and the hazards involved.

RESERVOIR: The tank mounted to the press that holds the hydraulic fluid used to operate the press.

RESET POSITION: The position of the moving bolster when the clamp cylinder(s) has retracted to switch position. This is usually full open position.

RIGGER: One that is familiar with the moving, transporting, and installation of machinery.

SAFETY BLOCK: A prop that, when inserted between opposing machine or tool members, prevents the press from closing of its own dead weight.

SLING: A device used to lift or support a machine or component.

SLOWDOWN POSITION: The position of the moving bolster when the clamp speed slows to pressing speed. This is usually 1/8 inch of being fully closed.

STRESS/TIE ROD: The round bar that is usually threaded at on both ends that the bolsters are mounted to and support the total load (tonnage) of the clamp assembly. The moving bolster slides on these rods also.

STRIP HEATER: A flat rectangular shaped electric resistive heating device that is typically placed under a platen or mold.

STROKE: The amount of travel the rod of a cylinder can extend and retract.

TWO HAND CONTROL: The control that requires the concurrent use (at the same time) of both of the operator's hands to both initiate and continue the press cycle during the hazardous portion of the press cycle.

UP-ACTING CLAMP: A clamp assembly where the moving bolsters travels upward to apply pressure.

WARNING: A term used to indicate a potentially hazardous situation that, if not avoided could result in death or serious injury.



0
1
2
3
4
5
6



GO TO EDIT RECIPE SUBROUTINE

RECIPE SUBROUTINE

JSR
Jump To Subroutine
SBR File Number U:3

ALARMS SUBROUTINE

JSR
Jump To Subroutine
SBR File Number U:6

MCR ZONE

HYDRAULIC PUMP ENABLED
CR4
I:0/8

(MCR)

ANTI-TIE DOWN TIMER

CLAMP CLOSE BUTTON
PB8
I:0/0

ANTI-TIE DOWN TO

TON

Timer On Delay
Timer T4:0
Time Base 0.01
Preset 50<
Accum 0<

CLAMP CLOSE BUTTON
PB9
I:0/1

CLOSED UNDER PRESSURE DELAY

CLAMP SEALED LIGHT
LT1
O:0/1

CLOSED UNDER PRESSURE DELAY

TON

Timer On Delay
Timer T4:10
Time Base 0.01
Preset 30<
Accum 0<

CLAMP CLOSED UNDER PRESSURE LATCH

CLAMP SEALED LIGHT
LT1
O:0/1

CLOSED UNDER PRESSURE DELAY
T4:10/DN

CLAMP CLOSED PRESSURE SWITCH
PS1
I:0/6

OPEN ENABLE
B1
B3/1

CLAMP UNDER PRESSURE LATCH
B27
B3/27

CLAMP UNDER PRESSURE LATCH
B27
B3/27

CLAMP CLOSE ENABLE

CLAMP CLOSE BUTTON
PB8
I:0/0

CLAMP CLOSE BUTTON
PB9
I:0/1

ANTI-TIE DOWN TO/DN
T4:0/DN

CLOSE ENABLE
B0
B3/0

CLOSE ENABLE
B0
B3/0

CLAMP SEALED LIGHT

CLOSE ENABLE
B0
B3/0

CLAMP SLOW DOWN
PRS2
I:0/5

GUARD DOOR CLOSED SWITCH
DS1
I:0/7

AUTO CYCLE COMPLETE
B31
B3/31

CLAMP SEALED LIGHT
LT1
O:0/1

CLAMP SEALED LIGHT
LT1
O:0/1

OPEN ENABLE
B1
B3/1

CLAMP UNDER PRESSURE LATCH
B27
B3/27

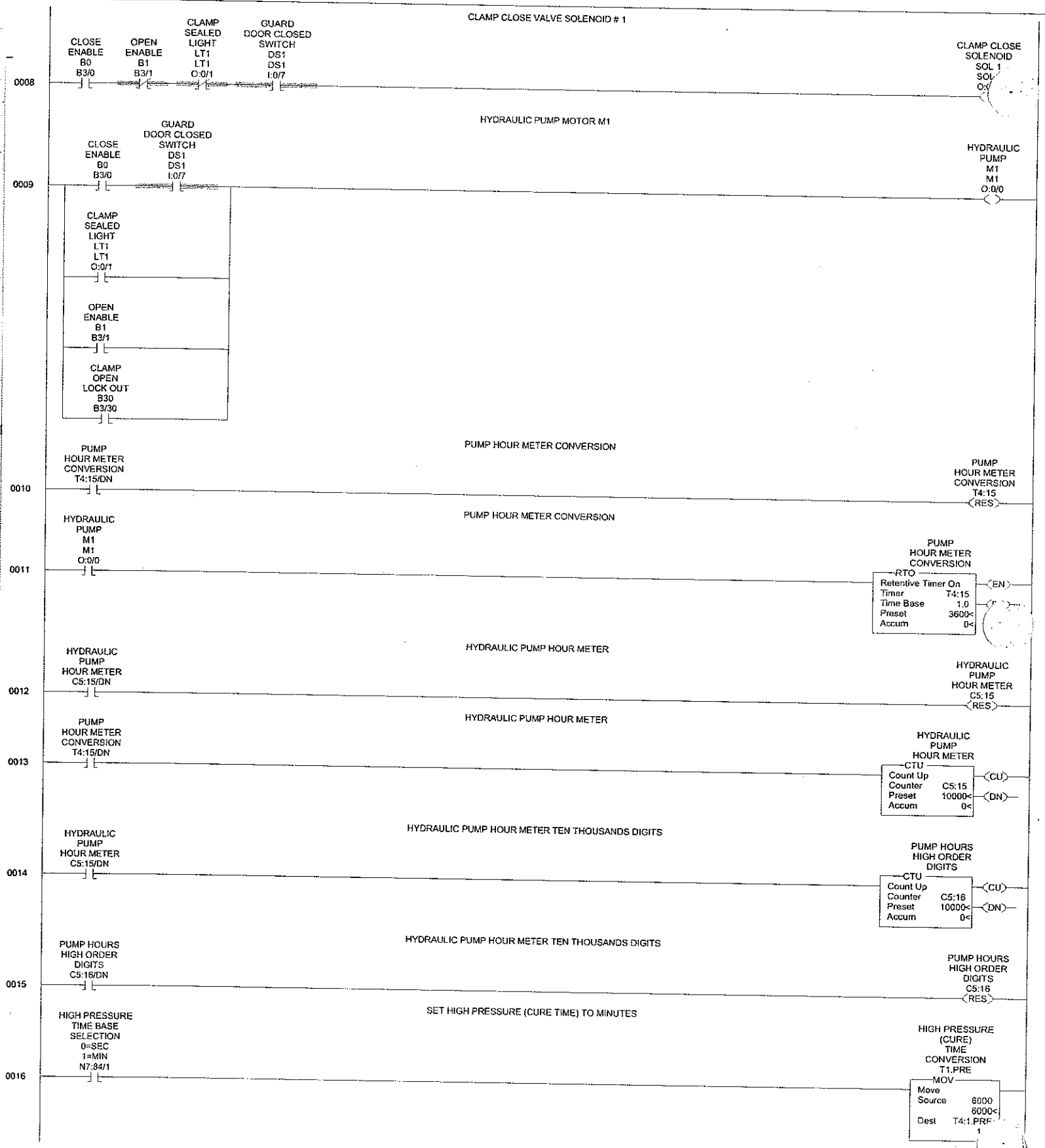

SET HIGH PRESSURE (CURE TIME) TO SECONDS

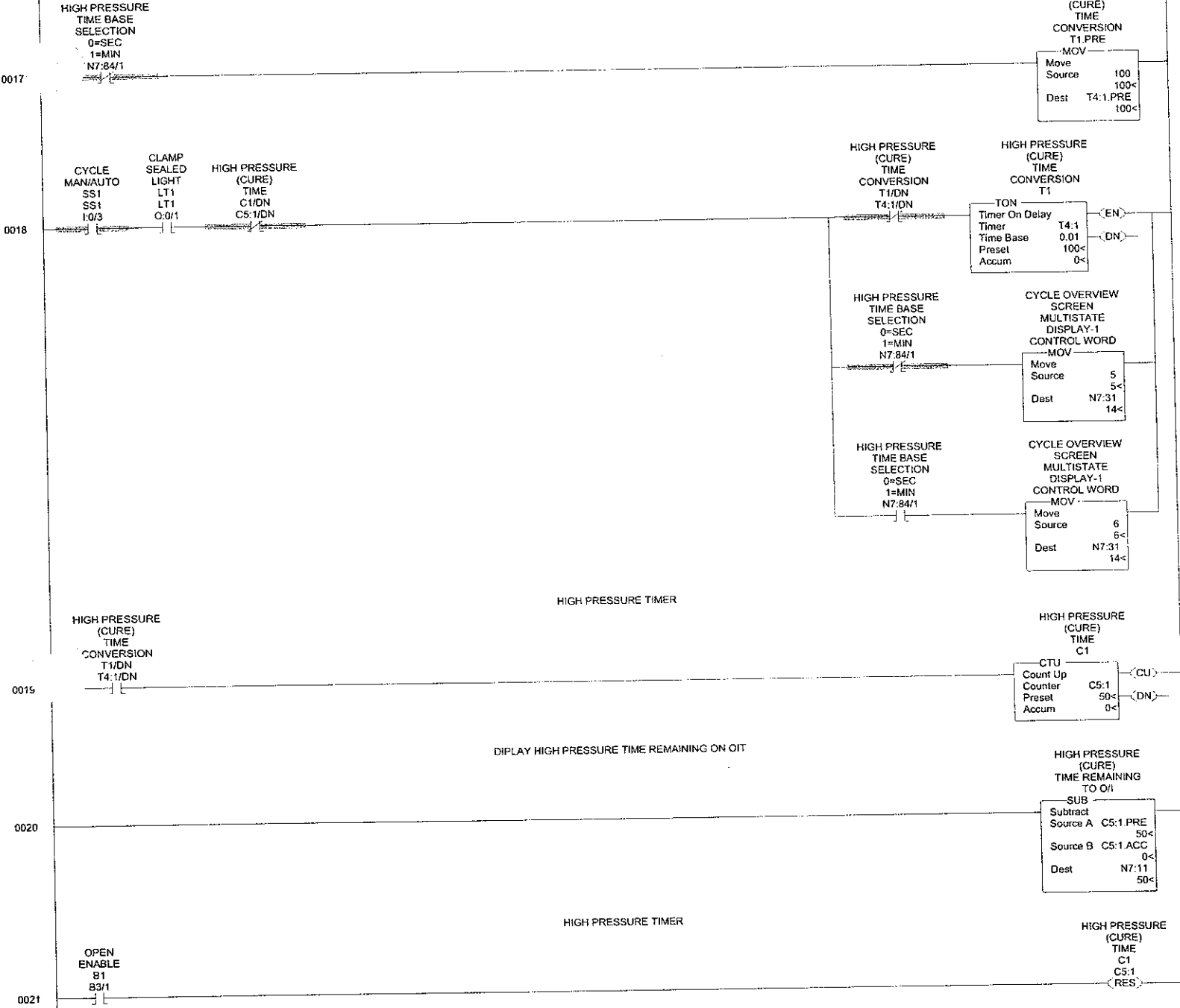

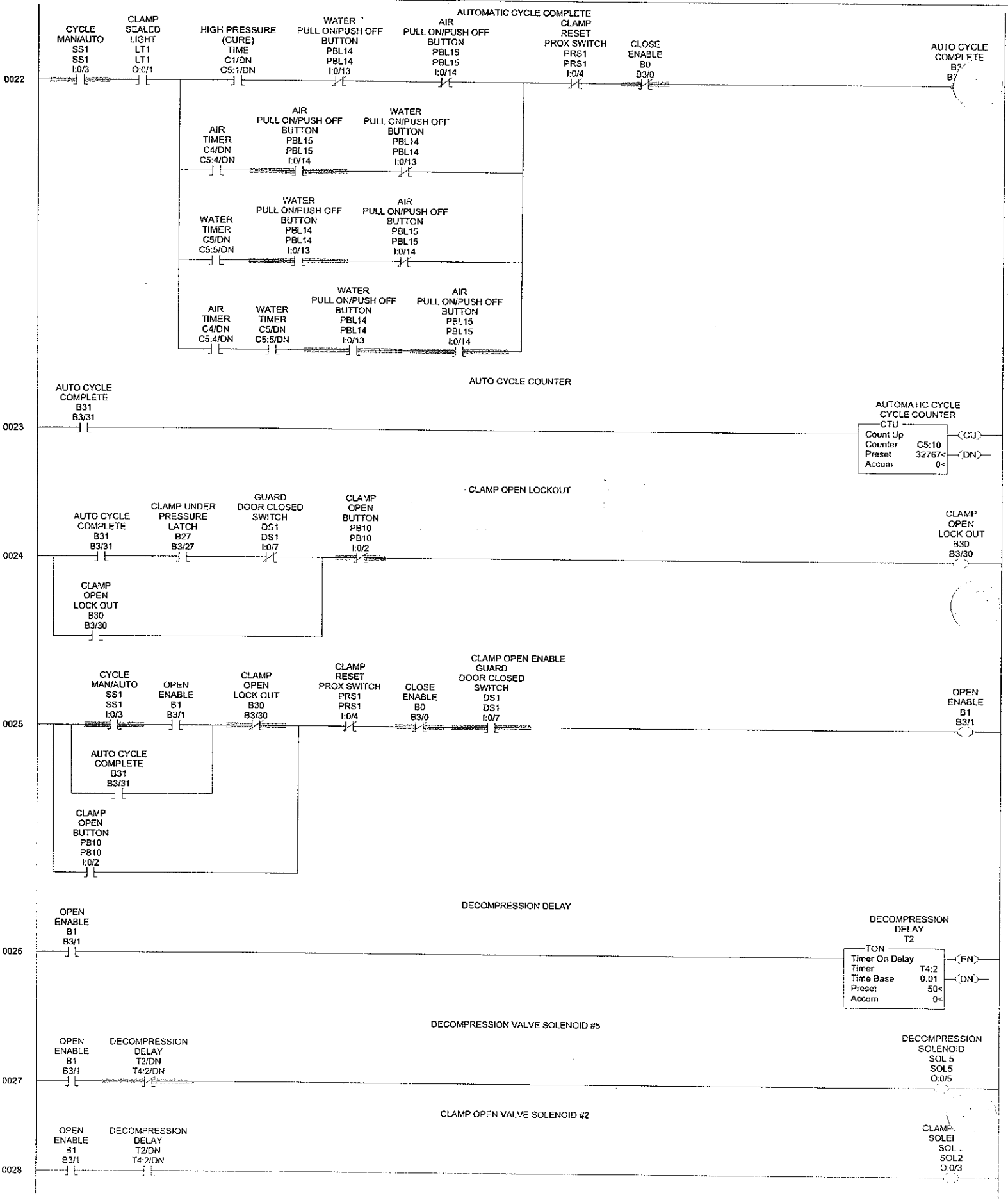

END MCR ZONE

(MCR)

0029

CYCLE
MAN/AUTO
SS1
SS1
I:0/3

CYCLE OVERVIEW
SCREEN
MULTISTATE
DISPLAY-1
CONTROL WORD

MOV

Move	
Source	13
	13<
Dest	N7:31
	14<

0030

CYCLE MAN/AUTO SS1 SS1 I:0/3	CLAMP SEALED LIGHT LT1 LT1 O:0/1	CLOSE ENABLE B0 B3/0	OPEN ENABLE B1 B3/1	AIR PURGE ENABLE B7 B3/7
--	---	-------------------------------	------------------------------	--------------------------------------

CYCLE OVERVIEW
SCREEN
MULTISTATE
DISPLAY-1
CONTROL WORD

MOV

Move	
Source	14
	14<
Dest	N7:31
	14<

0031

CLAMP
SEALED
LIGHT
LT1
LT1
O:0/1

CLOSE ENABLE B0 B3/0	AIR PURGE ENABLE B7 B3/7
OPEN ENABLE B1 B3/1	

CYCLE OVERVIEW
SCREEN
MULTISTATE
DISPLAY-1
CONTROL WORD

MOV

Move	
Source	0
	0<
Dest	N7:31
	14<

0032

CYCLE OVERVIEW
SCREEN
MULTISTATE
DISPLAY-2
CONTROL WORD

MOV

Move	
Source	0
	0<
Dest	N7:32
	0<

RESET AUTO CYCLE COUNTER

0033

CYCLE COUNTER
RESET
B3/32

AUTOMATIC CYCLE
CYCLE COUNTER
C5:10/DN

SCREEN NUMBER
BEING DISPLAYED
BY PANELVIEW

ECU

Equal	
Source A	N7:1
	3<
Source B	11
	11<

AUTOMATIC CYCLE
CYCLE COUNTER
C5:10

(RES)

CYCLE COUNTER
RESET
B3/32

(U)

COOLING ON CR 3

0034

WATER
VALVE
SOL<
SOL W1
SOLW1
O:0/11

COOLING
ON
CR3
CR3
O:0/12

AIR
VALVE
SOL<
SOL P1
SOLP1
O:0/10

HEAT OFF CR 2

0035

CYCLE MAN/AUTO SS1 SS1 I:0/3	OPEN ENABLE B1 B3/1
--	------------------------------

HEAT
OFF
CR2
CR2
O:0/13

SET AIR TIME TO MINUTES

0036

AIR COOLING
TIME BASE
SELECTION
0=SEC
1=MIN
N7:84/2

AIR
MINUTE/SECONDS
CONVERSION
T4:PRE

MOV

Move	
Source	6000
	6000<
Dest	T4:4,PRE
	6000<

SET AIR TIME TO SECONDS

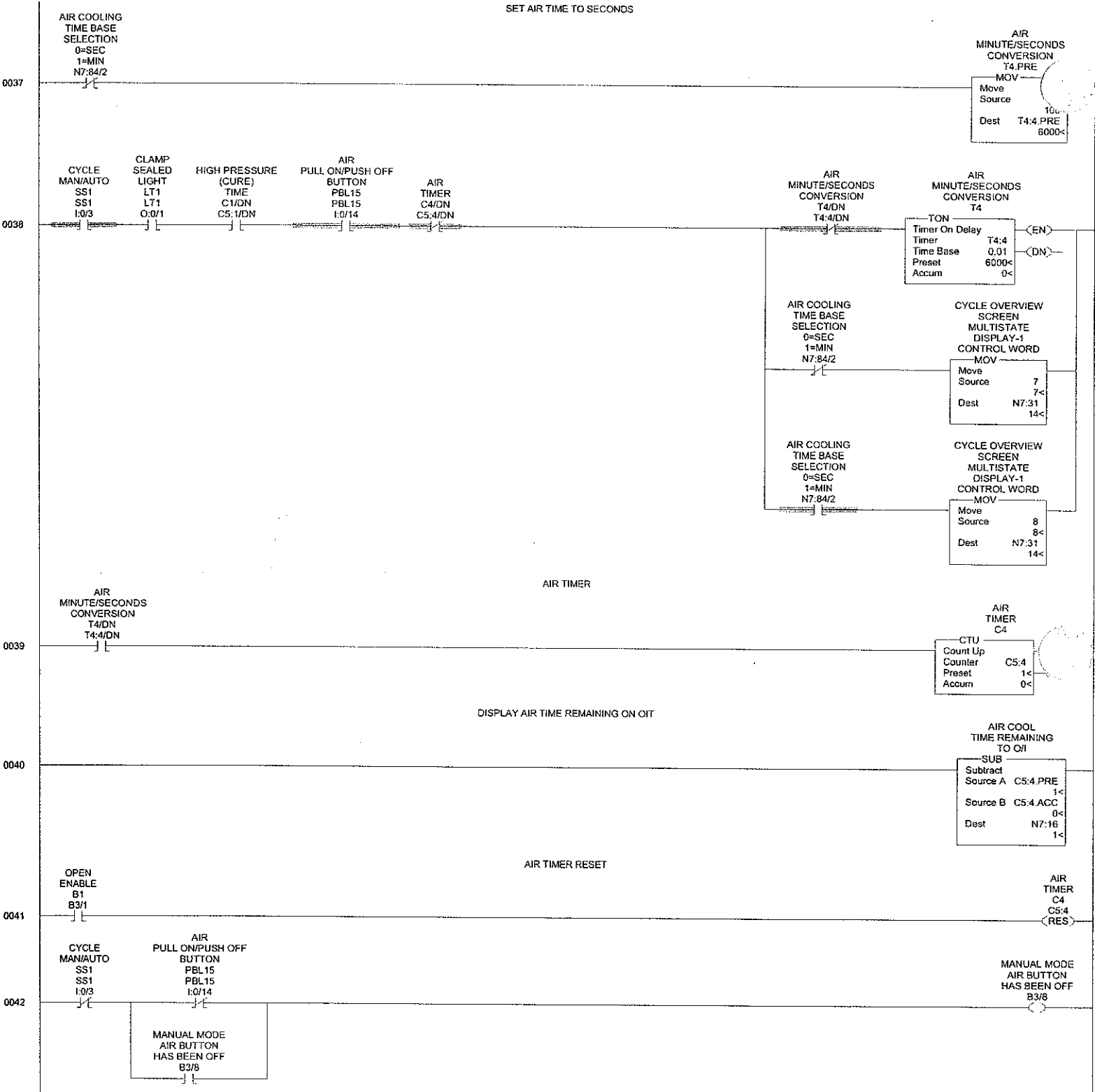

AIR VALVE AND LIGHT

AIR VALVE SOL< SOL P1 SOL P1 O:0/10

HIGH PRESSURE (CURE) TIME C1/DN C5:1/DN
AIR PULL ON/PUSH OFF BUTTON PBL15 PBL15 I:0/14
AIR TIMER C4/DN C5:4/DN

CYCLE MAN/AUTO SS1 SS1 I:0/3
AIR PULL ON/PUSH OFF BUTTON PBL15 PBL15 I:0/14
MANUAL MODE AIR BUTTON HAS BEEN OFF B3/8

AIR PURGE ENABLE B7 B3/7
AIR PURGE TIME C6/DN C5:6/DN

SET WATER TIME TO MINUTES

WATER COOLING TIME BASE SELECTION 0=SEC 1=MIN N7:84/3

WATER MINUTE/SECONDS CONVERSION T5.PRE
MOV Move Source 6000 6000< Dest T4:5.PRE 100<

SET WATER TIME TO SECONDS

WATER COOLING TIME BASE SELECTION 0=SEC 1=MIN N7:84/3

WATER MINUTE/SECONDS CONVERSION T5.PRE
MOV Move Source 100 100< Dest T4:5.PRE 100<

CYCLE MAN/AUTO SS1 SS1 I:0/3
CLAMP SEALED LIGHT LT1 LT1 O:0/1
HIGH PRESSURE (CURE) TIME C1/DN C5:1/DN
WATER PULL ON/PUSH OFF BUTTON PBL14 PBL14 I:0/13
WATER TIMER C5/DN C5:5/DN

WATER MINUTE/SECONDS CONVERSION T5/DN T4:5/DN

WATER MINUTE/SECONDS CONVERSION T5
TON Timer On Delay T4:5 EN DN Preset 0.01 100< Accum 0<

WATER COOLING TIME BASE SELECTION 0=SEC 1=MIN N7:84/3

CYCLE OVERVIEW SCREEN MULTISTATE DISPLAY-2 CONTROL WORD MOV Move Source 7 7< Dest N7:32 0<

WATER COOLING TIME BASE SELECTION 0=SEC 1=MIN N7:84/3

CYCLE OVERVIEW SCREEN MULTISTATE DISPLAY-2 CONTROL WORD MOV Move Source 8 8< Dest N7:32 0<

WATER TIMER RESET

WATER MINUTE/SECONDS CONVERSION T5/DN T4:5/DN

WATER TIMER C5
CTU Count Up Counter Preset 65< Accum 0< CU DN

DISPLAY WATER TIME REMAINING ON OIT

WATER COOL TIME REMAINING TO OIT
SUB Subtract Source A C5:5.PRE 65< Source B C5:5.ACC 0< Dest N7:17 65<

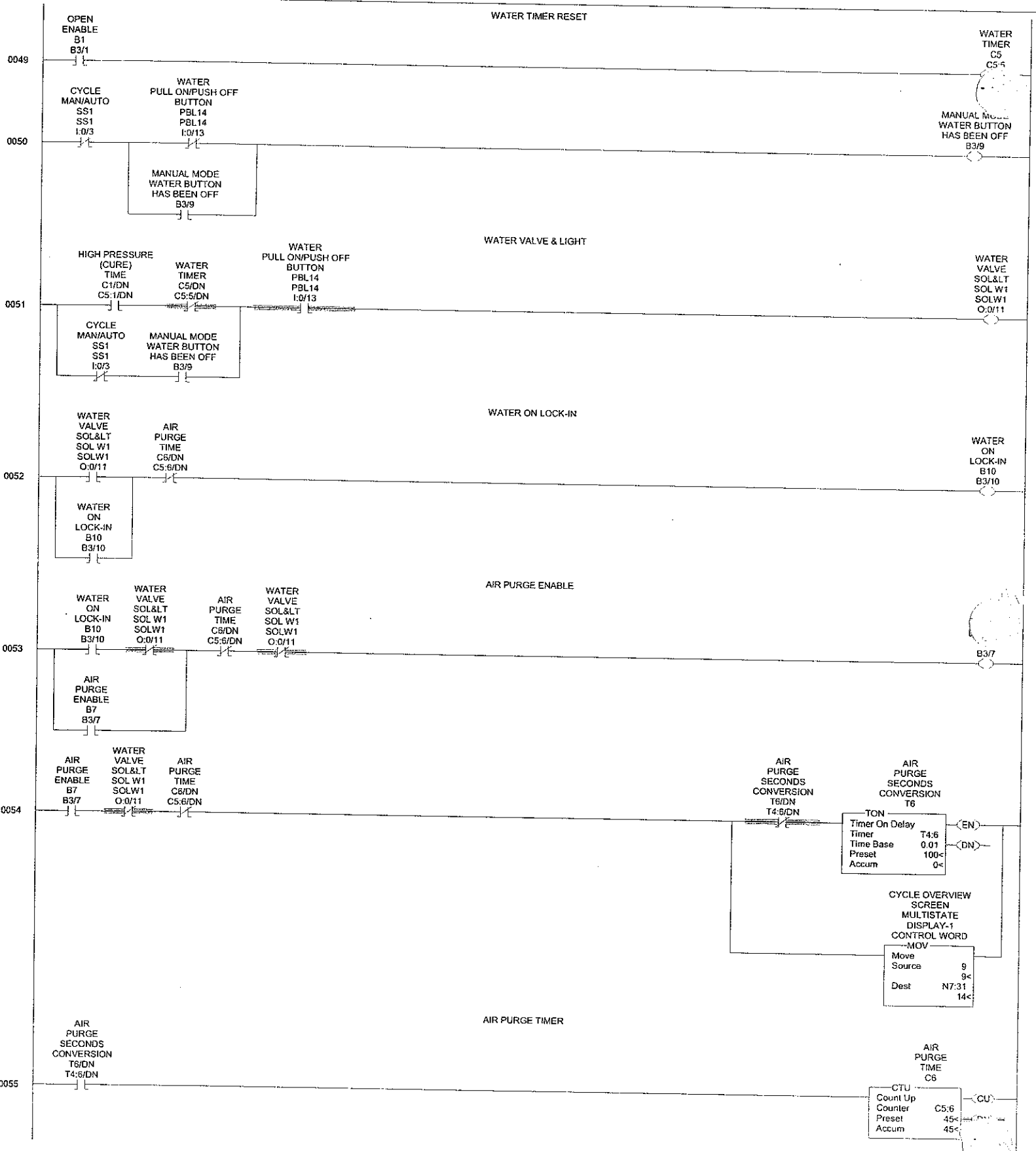

DISPLAY AIR PURGE TIME REMAINING ON OIT

AIR PURGE
TIME REMAINING
TO O/I

SUB	
Subtract	
Source A	C5:6.PRE 45<
Source B	C5:6.ACC 45<
Dest	N7:18 0<

AIR PURGE TIMER

AIR
PURGE
TIME
C6
C5:6
(RES)

WATER
VALVE
SOL<
SOL W1
SOLW1
O:0/11

(END)

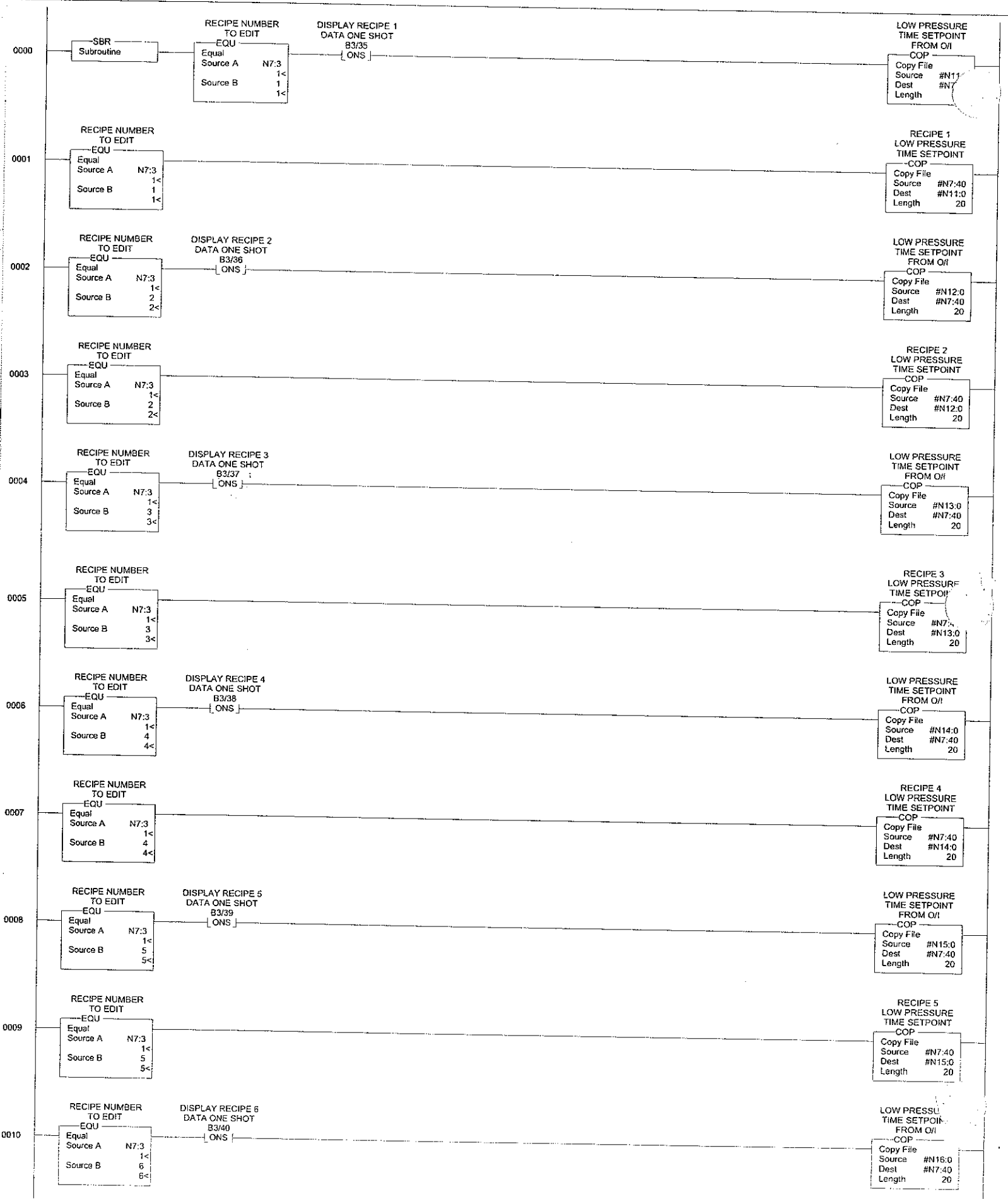

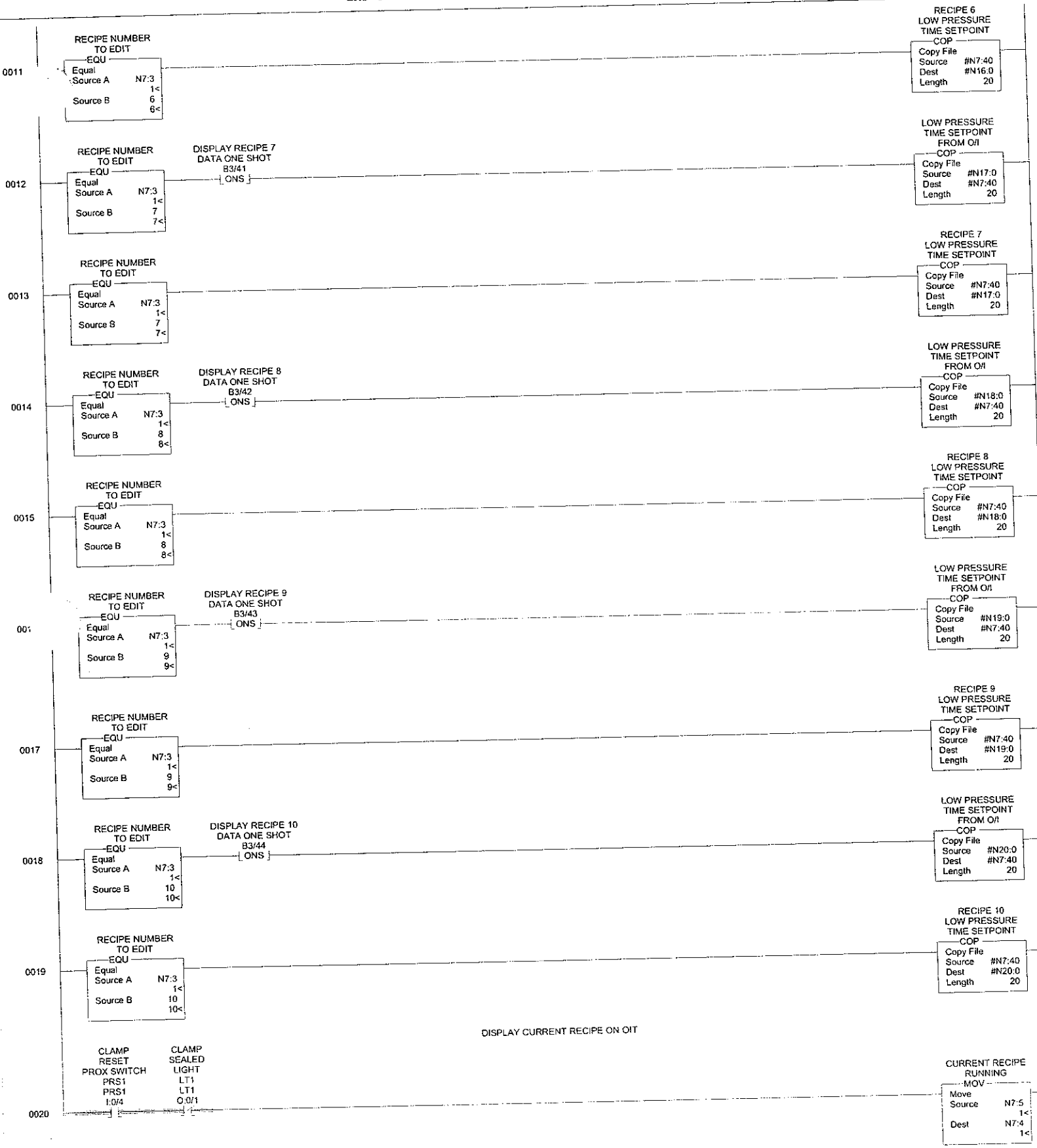

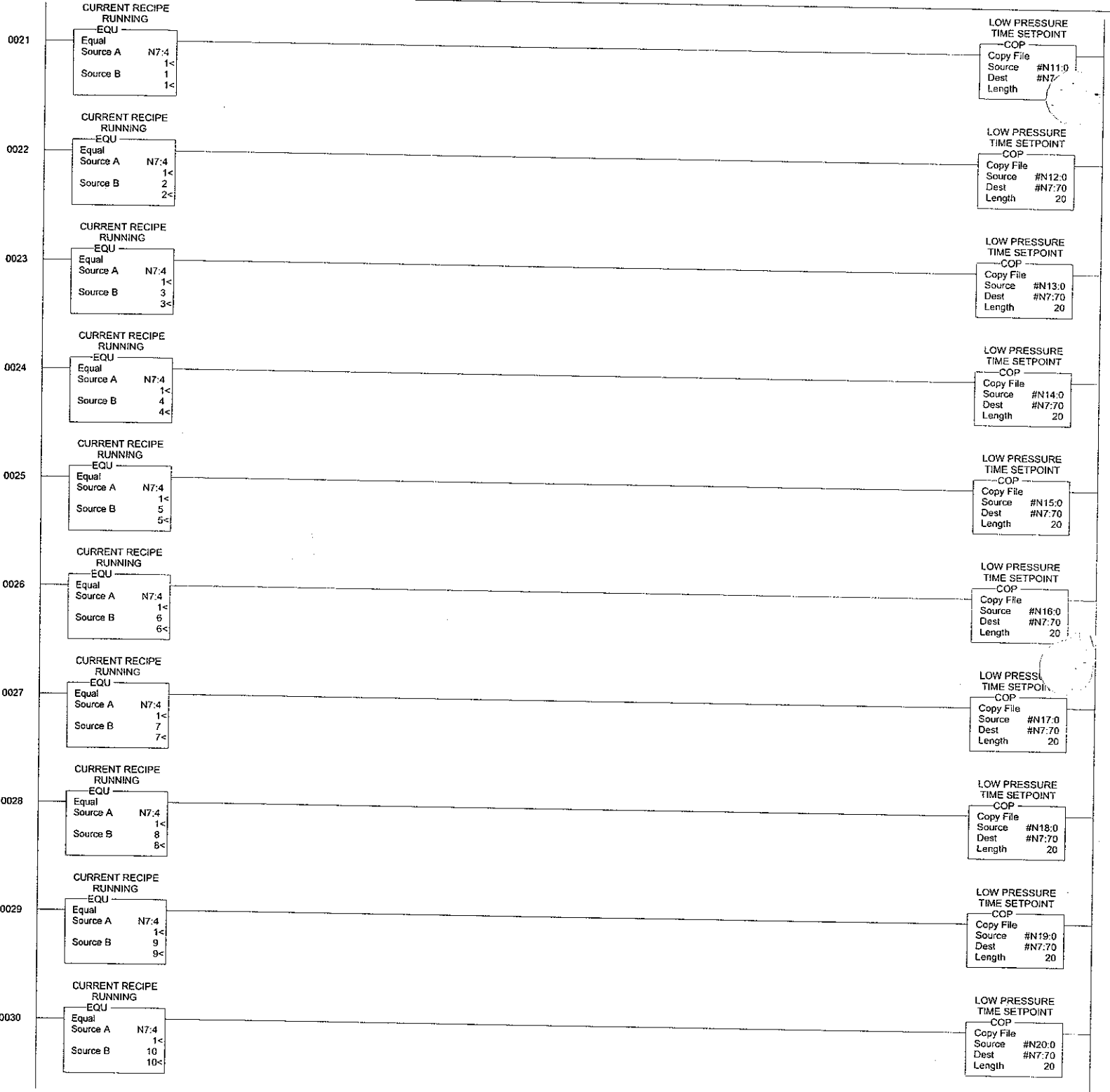

CLAMP
RESET
PROX SWITCH
PRS1
PRS1
I04

LOW PRESSURE
TIME
C3.PRE

MOV
Move
Source N7:70
Dest C5:3.PRE
20<
20<

HIGH PRESSURE
(CURE)
TIME
C1.PRE

MOV
Move
Source N7:71
Dest C5:1.PRE
50<
50<

PRE-BUMP
DWELL
TIME
C11.PRE

MOV
Move
Source N7:72
Dest C5:11.PRE
7<
7<

BUMP
OPEN
TIME
T12.PRE

MOV
Move
Source N7:73
Dest T4:12.PRE
100<
100<

DWELL
BETWEEN
BUMPS
C13.PRE

MOV
Move
Source N7:74
Dest C5:13.PRE
9<
9<

BUMP
COUNTS
C14.PRE

MOV
Move
Source N7:75
Dest C5:14.PRE
2<
2<

AIR
TIMER
C4.PRE

MOV
Move
Source N7:76
Dest C5:4.PRE
1<
1<

WATER
TIMER
C5.PRE

MOV
Move
Source N7:77
Dest C5:5.PRE
65<
65<

RET
Return

END

003

0032

0033

0000

PLC FAULT
CODE DISPLAYED
ON PANELVIEW

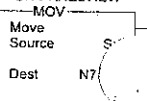

0001

PLC FAULT
ALARM
N7:110/4

0002

END



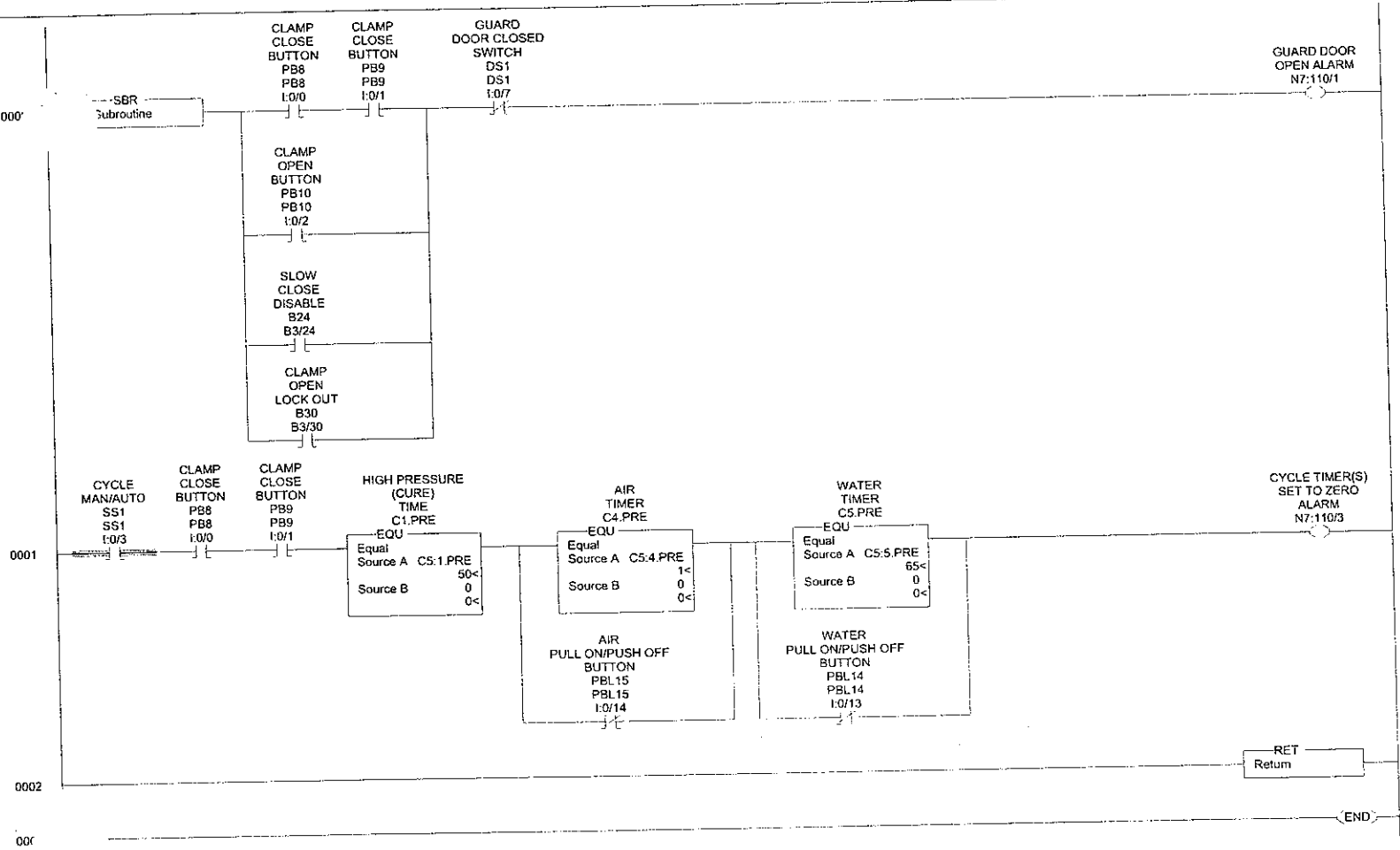

RSLogix 500 Cross Reference Report - Sorted by Address

0:0/0 - {M1} HYDRAULIC PUMP M1
 OTE - File #2 MAIN - 9
 XIC - File #2 MAIN - 11
 0:0/1 - {LT1} CLAMP SEALED LIGHT LT1
 OTE - File #2 MAIN - 7
 XIC - File #2 MAIN - 4, 5, 7, 9, 18, 22, 38, 46
 XIO - File #2 MAIN - 8, 31, 32
 File #3 RECIPE - 20
 0:0/2 - {SOL1} CLAMP CLOSE SOLENOID SOL 1
 OTE - File #2 MAIN - 8
 0:0/3 - {SOL2} CLAMP OPEN SOLENOID SOL 2
 OTE - File #2 MAIN - 28
 0:0/5 - {SOL5} DECOMPRESSION SOLENOID SOL 5
 OTE - File #2 MAIN - 27
 0:0/10 - {SOLP1} AIR VALVE SOL< SOL P1
 OTE - File #2 MAIN - 43
 XIC - File #2 MAIN - 34
 0:0/11 - {SOLW1} WATER VALVE SOL< SOL W1
 OTE - File #2 MAIN - 51
 XIC - File #2 MAIN - 34, 52, 57
 XIO - File #2 MAIN - 53, 54
 0:0/12 - {CR3} COOLING ON CR3
 OTE - File #2 MAIN - 34
 0:0/13 - {CR2} HEAT OFF CR2
 OTE - File #2 MAIN - 35
 I:0/0 - {PB8} CLAMP CLOSE BUTTON PB8
 XIC - File #2 MAIN - 3, 6
 File #6 ALARMS - 0, 1
 I:0/1 - {PB9} CLAMP CLOSE BUTTON PB9
 XIC - File #2 MAIN - 3, 6
 File #6 ALARMS - 0, 1
 I:0/2 - {PB10} CLAMP OPEN BUTTON PB10
 XIC - File #2 MAIN - 25
 File #6 ALARMS - 0
 XIO - File #2 MAIN - 24
 I:0/3 - {SS1} CYCLE MAN/AUTO SS1
 XIC - File #2 MAIN - 18, 22, 25, 31, 35, 38, 46
 File #6 ALARMS - 1
 XIO - File #2 MAIN - 30, 42, 43, 50, 51
 I:0/4 - {PRS1} CLAMP RESET PROX SWITCH PRS1
 XIC - File #3 RECIPE - 20, 31
 XIO - File #2 MAIN - 22, 25
 I:0/5 - {PRS2} CLAMP SLOW DOWN PROX PRS2
 XIC - File #2 MAIN - 7
 I:0/6 - {PS1} CLAMP CLOSED PRESSURE SWITCH PS1
 XIC - File #2 MAIN - 5
 I:0/7 - {DS1} GUARD DOOR CLOSED SWITCH DS1
 XIC - File #2 MAIN - 7, 8, 9, 25
 XIO - File #2 MAIN - 24
 File #6 ALARMS - 0
 I:0/8 - {CR4} HYDRAULIC PUMP ENABLED CR4
 XIC - File #2 MAIN - 2
 I:0/13 - {PBL14} WATER PULL ON/PUSH OFF BUTTON PBL14
 XIC - File #2 MAIN - 22, 46, 51
 XIO - File #2 MAIN - 22, 50
 File #6 ALARMS - 1
 I:0/14 - {PBL15} AIR PULL ON/PUSH OFF BUTTON PBL15
 XIC - File #2 MAIN - 22, 38, 43
 XIO - File #2 MAIN - 22, 42
 File #6 ALARMS - 1
 S:6 - Major Error Fault Code
 MOV - File #5 FAULT - 0
 B3/0 - {B0} CLOSE ENABLE
 OTE - File #2 MAIN - 6
 XIC - File #2 MAIN - 6, 7, 8, 9, 32
 XIO - File #2 MAIN - 22, 25, 31
 B3/1 - {B1} OPEN ENABLE
 OTE - File #2 MAIN - 25
 XIC - File #2 MAIN - 9, 21, 25, 26, 27, 28, 32, 35, 41, 49
 XIO - File #2 MAIN - 5, 7, 8, 31
 B3/7 - {B7} AIR PURGE ENABLE
 OTE - File #2 MAIN - 53
 XIC - File #2 MAIN - 43, 53, 54
 XIO - File #2 MAIN - 31, 32
 B3/8 - MANUAL MODE AIR BUTTON HAS BEEN OFF
 OTE - File #2 MAIN - 42
 XIC - File #2 MAIN - 42, 43
 B3/9 - MANUAL MODE WATER BUTTON HAS BEEN OFF
 OTE - File #2 MAIN - 50
 XIC - File #2 MAIN - 50, 51
 B3/10 - {B10} WATER ON LOCK-IN
 OTE - File #2 MAIN - 52
 XIC - File #2 MAIN - 52, 53
 B3/24 - {B24} SLOW CLOSE DISABLE
 XIC - File #6 ALARMS - 0
 B3/27 - {B27} CLAMP UNDER PRESSURE LATCH
 OTE - File #2 MAIN - 5
 XIC - File #2 MAIN - 5, 7, 24

```

B3/30 - {B30} CLAMP OPEN LOCK OUT
      OTE - File #2 MAIN - 24
      XIC - File #2 MAIN - 9, 24
          File #6 ALARMS - 0
      XIO - File #2 MAIN - 25
      - {B31} AUTO CYCLE COMPLETE
      OTE - File #2 MAIN - 22
      XIC - File #2 MAIN - 23, 24, 25
      XIO - File #2 MAIN - 7
B3/32 - CYCLE COUNTER RESET
      OTU - File #2 MAIN - 33
      XIC - File #2 MAIN - 33
B3/35 - DISPLAY RECIPE 1 DATA ONE SHOT
      ONS - File #3 RECIPE - 0
B3/36 - DISPLAY RECIPE 2 DATA ONE SHOT
      ONS - File #3 RECIPE - 2
B3/37 - DISPLAY RECIPE 3 DATA ONE SHOT
      ONS - File #3 RECIPE - 4
B3/38 - DISPLAY RECIPE 4 DATA ONE SHOT
      ONS - File #3 RECIPE - 6
B3/39 - DISPLAY RECIPE 5 DATA ONE SHOT
      ONS - File #3 RECIPE - 8
B3/40 - DISPLAY RECIPE 6 DATA ONE SHOT
      ONS - File #3 RECIPE - 10
B3/41 - DISPLAY RECIPE 7 DATA ONE SHOT
      ONS - File #3 RECIPE - 12
B3/42 - DISPLAY RECIPE 8 DATA ONE SHOT
      ONS - File #3 RECIPE - 14
B3/43 - DISPLAY RECIPE 9 DATA ONE SHOT
      ONS - File #3 RECIPE - 16
B3/44 - DISPLAY RECIPE 10 DATA ONE SHOT
      ONS - File #3 RECIPE - 18
T4:0 - {T0} ANTI-TIE DOWN
      TON - File #2 MAIN - 3
      XIO - File #2 MAIN - 6
T4:0/DN
T4:1 - {T1} HIGH PRESSURE (CURE) TIME CONVERSION
      TON - File #2 MAIN - 18
      XIC - File #2 MAIN - 19
      XIO - File #2 MAIN - 18
T4:1/DN
T4:1.PRE
1:2 - {T2} DECOMPRESSION DELAY
      TON - File #2 MAIN - 26
      XIC - File #2 MAIN - 28
      XIO - File #2 MAIN - 27
      /DN
T4:4 - {T4} AIR MINUTE/SECONDS CONVERSION
      TON - File #2 MAIN - 38
      XIC - File #2 MAIN - 39
      XIO - File #2 MAIN - 38
T4:4/DN
T4:4.PRE
T4:5 - {T5} WATER MINUTE/SECONDS CONVERSION
      TON - File #2 MAIN - 46
      XIC - File #2 MAIN - 47
      XIO - File #2 MAIN - 46
      MOV - File #2 MAIN - 44, 45
T4:5/DN
T4:5.PRE
T4:6 - {T6} AIR PURGE SECONDS CONVERSION
      TON - File #2 MAIN - 54
      XIC - File #2 MAIN - 55
      XIO - File #2 MAIN - 54
T4:6/DN
T4:10 - CLOSED UNDER PRESSURE DELAY
      TON - File #2 MAIN - 4
      XIC - File #2 MAIN - 5
      MOV - File #3 RECIPE - 31
T4:10/DN
T4:12.PRE
T4:15 - PUMP HOUR METER CONVERSION
      RTO - File #2 MAIN - 11
      RES - File #2 MAIN - 10
      XIC - File #2 MAIN - 10, 13
T4:15/DN
C5:1 - {C1} HIGH PRESSURE (CURE) TIME
      CTU - File #2 MAIN - 19
      RES - File #2 MAIN - 21
      XIC - File #2 MAIN - 22, 38, 43, 46, 51
      XIO - File #2 MAIN - 18
C5:1/DN
C5:1.PRE
      MOV - File #3 RECIPE - 31
      SUB - File #2 MAIN - 20
      EQU - File #6 ALARMS - 1
C5:1.ACC
C5:3.PRE
C5:4 - {C4} AIR TIMER
      CTU - File #2 MAIN - 39
      RES - File #2 MAIN - 41
      XIC - File #2 MAIN - 22
      XIO - File #2 MAIN - 38, 43
      MOV - File #3 RECIPE - 31
      SUB - File #2 MAIN - 40
      EQU - File #6 ALARMS - 1
      /DN
C5:4.PRE
      SUB - File #2 MAIN - 40
C5:4.ACC
C5:5 - {C5} WATER TIMER
      CTU - File #2 MAIN - 47
      RES - File #2 MAIN - 49

```

RSLogix 500 Cross Reference Report - Sorted by Address

C5:5/DN - XIC - File #2 MAIN - 22
 XIO - File #2 MAIN - 46, 51
 C5:5.PRE - MOV - File #3 RECIPE - 31
 SUB - File #2 MAIN - 48
 EQU - File #6 ALARMS - 1
 C5:5.ACC - SUB - File #2 MAIN - 48
 C5:6 - {C6} AIR PURGE TIME
 CTU - File #2 MAIN - 55
 RES - File #2 MAIN - 57
 C5:6/DN - XIO - File #2 MAIN - 43, 52, 53, 54
 C5:6.PRE - SUB - File #2 MAIN - 56
 C5:6.ACC - SUB - File #2 MAIN - 56
 C5:10 - AUTOMATIC CYCLE CYCLE COUNTER
 CTU - File #2 MAIN - 23
 RES - File #2 MAIN - 33
 C5:10/DN - XIC - File #2 MAIN - 33
 C5:11.PRE - MOV - File #3 RECIPE - 31
 C5:13.PRE - MOV - File #3 RECIPE - 31
 C5:14.PRE - MOV - File #3 RECIPE - 31
 C5:15 - HYDRAULIC PUMP HOUR METER
 CTU - File #2 MAIN - 13
 RES - File #2 MAIN - 12
 C5:15/DN - XIC - File #2 MAIN - 12, 14
 C5:16 - PUMP HOURS HIGH ORDER DIGITS
 CTU - File #2 MAIN - 14
 RES - File #2 MAIN - 15
 C5:16/DN - XIC - File #2 MAIN - 15
 N7:1 - SCREEN NUMBER BEING DISPLAYED BY PANELVIEW
 EQU - File #2 MAIN - 33
 N7:3 - RECIPE NUMBER TO EDIT
 EQU - File #3 RECIPE - 0, 1, 2, 3, 4, 5, 6, 7, 8, 9, 10, 11, 12
 13, 14, 15, 16, 17, 18, 19
 N7:4 - CURRENT RECIPE RUNNING
 MOV - File #3 RECIPE - 20
 EQU - File #3 RECIPE - 21, 22, 23, 24, 25, 26, 27, 28, 29, 30
 N7:5 - RECIPE NUMBER TO RUN
 MOV - File #3 RECIPE - 20
 N7:11 - HIGH PRESSURE (CURE) TIME REMAINING TO O/I
 SUB - File #2 MAIN - 20
 N7:16 - AIR COOL TIME REMAINING TO O/I
 SUB - File #2 MAIN - 40
 N7:17 - WATER COOL TIME REMAINING TO O/I
 SUB - File #2 MAIN - 48
 N7:18 - AIR PURGE TIME REMAINING TO O/I
 SUB - File #2 MAIN - 56
 N7:31 - CYCLE OVERVIEW SCREEN MULTISTATE DISPLAY-1 CONTROL WORD
 MOV - File #2 MAIN - 18, 30, 31, 32, 38, 54
 N7:32 - CYCLE OVERVIEW SCREEN MULTISTATE DISPLAY-2 CONTROL WORD
 MOV - File #2 MAIN - 32, 46
 N7:40 - LOW PRESSURE TIME SETPOINT FROM O/I
 COP - File #3 RECIPE - 0, 1, 2, 3, 4, 5, 6, 7, 8, 9, 10, 11, 12
 13, 14, 15, 16, 17, 18, 19
 FILE N7:40 LEN:20 - COP - File #3 RECIPE - 0, 1, 2, 3, 4, 5, 6, 7, 8, 9, 10, 11
 12, 13, 14, 15, 16, 17, 18, 19
 N7:70 - LOW PRESSURE TIME SETPOINT
 MOV - File #3 RECIPE - 31
 COP - File #3 RECIPE - 21, 22, 23, 24, 25, 26, 27, 28, 29, 30
 FILE N7:70 LEN:20 - COP - File #3 RECIPE - 21, 22, 23, 24, 25, 26, 27, 28, 29, 30
 N7:71 - HIGH PRESSURE (CURE) TIME SETPOINT
 MOV - File #3 RECIPE - 31
 FILE N7:71 LEN:19 - COP - File #3 RECIPE - 21, 22, 23, 24, 25, 26, 27, 28, 29, 30
 N7:72 - PRE-BUMP DWELL TIME SETPOINT
 MOV - File #3 RECIPE - 31
 FILE N7:72 LEN:18 - COP - File #3 RECIPE - 21, 22, 23, 24, 25, 26, 27, 28, 29, 30
 N7:73 - BUMP OPEN TIME SETPOINT
 MOV - File #3 RECIPE - 31
 FILE N7:73 LEN:17 - COP - File #3 RECIPE - 21, 22, 23, 24, 25, 26, 27, 28, 29, 30
 N7:74 - DWELL BETWEEN BUMPS TIME
 MOV - File #3 RECIPE - 31
 FILE N7:74 LEN:16 - COP - File #3 RECIPE - 21, 22, 23, 24, 25, 26, 27, 28, 29, 30
 N7:75 - NUMBER OF BUMPS SETPOINT
 MOV - File #3 RECIPE - 31
 FILE N7:75 LEN:15 - COP - File #3 RECIPE - 21, 22, 23, 24, 25, 26, 27, 28, 29, 30
 N7:76 - AIR COOL TIME SETPOINT
 MOV - File #3 RECIPE - 31
 FILE N7:76 LEN:14 - COP - File #3 RECIPE - 21, 22, 23, 24, 25, 26, 27, 28, 29, 30
 N7:77 - WATER COOL TIME SETPOINT
 MOV - File #3 RECIPE - 31
 FILE N7:77 LEN:13 - COP - File #3 RECIPE - 21, 22, 23, 24, 25, 26, 27, 28, 29, 30
 N7:84/1 - HIGH PRESSURE TIME BASE SELECTION 0=SEC 1=MIN
 XIC - File #2 MAIN - 16, 18
 XIO - File #2 MAIN - 17, 18
 FILE N7:84/1 LEN:6 - COP - File #3 RECIPE - 21, 22, 23, 24, 25, 26, 27, 28, 29
 30
 N7:84/2 - AIR COOLING TIME BASE SELECTION 0=SEC 1=MIN
 XIC - File #2 MAIN - 36, 38
 XIO - File #2 MAIN - 37, 38
 FILE N7:84/2 LEN:6 - COP - File #3 RECIPE - 21, 22, 23, 24, 25, 26, 27, 28, 29

```

30
N7:84/3 - WATER COOLING TIME BASE SELECTION 0=SEC 1=MIN
        XIC - File #2 MAIN - 44, 46
        XIO - File #2 MAIN - 45, 46
N7:84/3 LEN:6 - COP - File #3 RECIPE - 21, 22, 23, 24, 25, 26, 27, 28, 29
30
...:110/1 - GUARD DOOR OPEN ALARM
        OTE - File #6 ALARMS - 0
N7:110/3 - CYCLE TIMER(S) SET TO ZERO ALARM
        OTE - File #6 ALARMS - 1
N7:110/4 - PLC FAULT ALARM
        OTE - File #5 FAULT - 1
N7:111 - PLC FAULT CODE DISPLAYED ON PANELVIEW
        MOV - File #5 FAULT - 0
N11:0 - RECIPE 1 LOW PRESSURE TIME SETPOINT
        COP - File #3 RECIPE - 0, 1, 21
FILE N11:0 LEN:20 - COP - File #3 RECIPE - 0, 1, 21
N12:0 - RECIPE 2 LOW PRESSURE TIME SETPOINT
        COP - File #3 RECIPE - 2, 3, 22
FILE N12:0 LEN:20 - COP - File #3 RECIPE - 2, 3, 22
N13:0 - RECIPE 3 LOW PRESSURE TIME SETPOINT
        COP - File #3 RECIPE - 4, 5, 23
FILE N13:0 LEN:20 - COP - File #3 RECIPE - 4, 5, 23
N14:0 - RECIPE 4 LOW PRESSURE TIME SETPOINT
        COP - File #3 RECIPE - 6, 7, 24
FILE N14:0 LEN:20 - COP - File #3 RECIPE - 6, 7, 24
N15:0 - RECIPE 5 LOW PRESSURE TIME SETPOINT
        COP - File #3 RECIPE - 8, 9, 25
FILE N15:0 LEN:20 - COP - File #3 RECIPE - 8, 9, 25
N16:0 - RECIPE 6 LOW PRESSURE TIME SETPOINT
        COP - File #3 RECIPE - 10, 11, 26
FILE N16:0 LEN:20 - COP - File #3 RECIPE - 10, 11, 26
N17:0 - RECIPE 7 LOW PRESSURE TIME SETPOINT
        COP - File #3 RECIPE - 12, 13, 27
FILE N17:0 LEN:20 - COP - File #3 RECIPE - 12, 13, 27
N18:0 - RECIPE 8 LOW PRESSURE TIME SETPOINT
        COP - File #3 RECIPE - 14, 15, 28
FILE N18:0 LEN:20 - COP - File #3 RECIPE - 14, 15, 28
N19:0 - RECIPE 9 LOW PRESSURE TIME SETPOINT
        COP - File #3 RECIPE - 16, 17, 29
FILE N19:0 LEN:20 - COP - File #3 RECIPE - 16, 17, 29
N20:0 - RECIPE 10 LOW PRESSURE TIME SETPOINT
        COP - File #3 RECIPE - 18, 19, 30
FILE N20:0 LEN:20 - COP - File #3 RECIPE - 18, 19, 30
U:3 - RECIPE SUBROUTINE
        JSR - File #2 MAIN - 0
U:6 - ALARMS SUBROUTINE
        JSR - File #2 MAIN - 1

```

