

IKA® WORKS

Operating Instructions

## LABOR-PILOT 2000/4



Serial Number:



## TABLE OF CONTENTS

<b>1</b>	<b>EC DECLARATION OF CONFORMITY .....</b>	<b>5</b>
<b>2</b>	<b>FOR YOUR SAFETY.....</b>	<b>7</b>
2.1	GENERAL DANGERS .....	7
2.2	DEFINITION .....	7
2.3	CORRECT USE .....	7
2.4	SAFETY PRECAUTIONS.....	7
2.4.1	<i>User's duty of care .....</i>	<i>7</i>
2.4.2	<i>Special safety information and symbols used.....</i>	<i>8</i>
2.4.3	<i>General safety information.....</i>	<i>9</i>
2.4.4	<i>Basic safety precautions during normal operation.....</i>	<i>9</i>
2.4.5	<i>Basic safety precautions during service and maintenance .....</i>	<i>11</i>
2.4.6	<i>Work on the electrical equipment .....</i>	<i>12</i>
2.4.7	<i>Observe the environmental protection regulations.....</i>	<i>12</i>
2.5	OTHER DANGERS .....	12
<b>3</b>	<b>DESCRIPTION OF THE LABOR-PILOT 2000/4.....</b>	<b>14</b>
3.1	BEFORE USING THE LABOR-PILOT .....	14
3.2	DESCRIPTION OF THE DEVICE.....	14
3.2.1	<i>Description of the main unit and of the attached notes .....</i>	<i>14</i>
3.2.2	<i>Electronic control .....</i>	<i>15</i>
3.3	PRINCIPLE OF OPERATION .....	16
3.3.1	<i>Modular design .....</i>	<i>16</i>
3.3.2	<i>Principle of operation of the basic device.....</i>	<i>17</i>
3.3.3	<i>Principle of operation of the Module DISPAX-REACTOR® DR.....</i>	<i>19</i>
3.3.4	<i>Principle of operation of the MHD module.....</i>	<i>20</i>
3.3.5	<i>Principle of operation of the Colloid mill MK module .....</i>	<i>21</i>
3.4	DIMENSIONS.....	23
3.4.1	<i>Figure 1 Dimension sheet.....</i>	<i>23</i>
3.4.2	<i>Figure 2 Dimension sheet.....</i>	<i>24</i>
3.4.3	<i>Figure 3 Dimension sheet.....</i>	<i>25</i>
3.4.4	<i>Dimension table .....</i>	<i>25</i>
<b>4</b>	<b>SPECIFICATIONS.....</b>	<b>26</b>
4.1	LABOR-PILOT .....	26
4.2	ELECTRICAL SYSTEM .....	27
4.2.1	<i>Motor:.....</i>	<i>27</i>
4.2.2	<i>LABOR-PILOT CONTROLLER.....</i>	<i>28</i>
4.2.3	<i>Power supply / Cable .....</i>	<i>29</i>
4.3	DIMENSIONS AND WEIGHTS OF LABOR-PILOT 2000/4:.....	29
<b>5</b>	<b>INSTALLATION.....</b>	<b>30</b>
5.1	MOUNTING AND ALIGNMENT OF THE MACHINE .....	30
5.2	PRODUCT CONNECTIONS .....	30
5.2.1	<i>Connection size at the inlet and outlet socket .....</i>	<i>30</i>
5.2.2	<i>Operation using flow-through processes.....</i>	<i>31</i>
	<i>Accessories for operation using circulation processes .....</i>	<i>32</i>
5.2.3.1	<i>Circulation pipe.....</i>	<i>33</i>
5.2.3.2	<i>Telescopic stand leg .....</i>	<i>33</i>



5.2.4	Connection on the suction side .....	34
5.2.5	Connection on the delivery side.....	35
5.2.6	Connection of the MHD module .....	36
5.3	HEATING/COOLING CONNECTIONS .....	37
5.4	VOLTAGE SUPPLY.....	38
<b>6</b>	<b>OPERATION .....</b>	<b>39</b>
6.1	OPERATING DEVICES OF THE MACHINE WITHOUT LABOR-PILOT CONTROLLER .....	39
6.1.1	Operating element.....	39
6.1.2	Functions.....	<i>Error! Bookmark not defined.</i>
6.1.3	Operation.....	<i>Error! Bookmark not defined.</i>
6.2	OPERATION OF THE LABOR-PILOT CONTROLLER.....	40
6.2.1	Abbreviations:.....	40
6.2.2	Design:.....	40
6.2.3	Controller speed range:.....	40
6.2.4	Installation.....	41
6.2.5	Wiring Diagram.....	42
6.2.6	Functions:.....	44
6.2.7	Operating elements:.....	44
6.2.8	Operation of the controller:.....	44
6.2.9	View of HMI display:.....	45
6.2.10	HMI function keys:.....	46
6.2.11	LEDs of the HMI:.....	47
6.2.12	View of all display pages:.....	48
<b>7</b>	<b>COMMISSIONING OF THE LABOR-PILOT 2000/4.....</b>	<b>54</b>
7.1	CONNECTING THE MACHINE.....	<b>ERROR! BOOKMARK NOT DEFINED.</b>
7.2	BRIEF TEST .....	55
7.3	INFORMATION ON WORKING WITH PRODUCT .....	56
7.3.1	Peripheral equipment .....	56
7.3.1.1	General .....	56
7.3.1.2	MHD module .....	56
7.3.2	Adaptation possibilities of the LABOR-PILOT to the process.....	57
7.3.2.1	General .....	57
7.3.2.2	Grinding gap adjustment MK module .....	58
7.3.3	Starting the machine.....	59
7.3.4	Calculation of the throughput rate.....	60
7.3.5	Operation using circulation processes with the hopper.....	61
<b>8</b>	<b>ASSEMBLY AND DISASSEMBLY.....</b>	<b>64</b>
8.1	FITTING TOOLS .....	65
8.2	DISASSEMBLY OF GENERATOR AND ROTARY SHAFT SEAL.....	66
8.3	ASSEMBLY OF ROTARY SHAFT SEAL.....	71
<b>9</b>	<b>MODIFICATION OF THE BASIC DEVICE TO OTHER MODULES .....</b>	<b>73</b>
9.1	GENERAL NOTES .....	73
9.2	PREPARATORY WORK:.....	73
9.3	MODIFICATION TO DR MODULE.....	74
9.3.1	Disassembly of pump unit.....	74
9.3.2	Assembly of DR module.....	74
9.4	MODIFICATION TO MHD MODULE .....	79
9.4.1	Disassembly of pump unit.....	79



9.4.2 Assembly of MHD module ..... 79

9.5 MODIFICATION TO MK MODULE..... 84

9.5.1 Disassembly of pump unit..... 84

9.5.2 Assembly of MK module ..... 84

**10 MAINTENANCE.....89**

10.1 THE ROTARY SHAFT SEAL ..... 89

10.2 THE GENERATORS..... 90

10.3 THE BEARINGS..... 90

10.4 DRIVE SHAFT ..... 90

10.4.1 Disassembly of the drive shaft..... 90

10.4.2 Assembly of drive shaft ..... 90

10.5 TENSIONING THE V-BELT ..... 91

**11 TROUBLES/CAUSES AND TROUBLESHOOTING .....93**

**12 ORDERING SPARE PARTS .....95**

**13 SPARE PARTS LIST AND DRAWINGS:.....95**

13.1 MACHINE SPARE PARTS LIST ..... 95

13.2 FIGURE 3 MACHINE SPARE PARTS DRAWING ..... 98

13.2.1 Figure 4 Detail of figure 3 ..... 99

13.2.2 Figure 5 Detail of figure 3 ..... 100

13.3 ..... 101

13.4 - DR MODULE SPARE PARTS LIST AND DRAWING ..... 101

13.5 - MHD MODULE SPARE PARTS LIST AND DRAWING ..... 103

13.6 - MK MODULE SPARE PARTS LIST AND DRAWING ..... 105

**14 APPENDIX .....106**

14.1 SCALE-UP ..... 106



## 1 EC Declaration of Conformity

**EC Declaration of Conformity  
as defined by EC Machinery Directive 98/37/EG, Appendix II A**

Herewith we, **IKA<sup>®</sup> - WERKE GMBH & Co. KG**  
Janke und Kunkel-Str. 10  
D - 79219 Staufen

declare that the below named machine on account of its design and construction as well as in the version we offer for sale complies with the relevant underlying safety and health requirements stipulated by the EC directives. In case of a modification of the machine which is not co-ordinated with us this declaration will no longer be valid.

Designation of the machine: **LABOR-PILOT**  
Machine type: **2000/4**

**Serial no.:**  
**Year of construction:** **2002**

Relevant EC directives: 98/37/EEC, Appendix II A  
Applied harmonised standards: EN 292-1  
EN 292-2  
EN 294  
EN 349  
EN 414  
EN 418

Applied national standards  
and technical specifications: DIN 42673  
DIN 42677  
DIN 11851  
DIN 50049  
VDE 0530 Part 5/ IEC 34 Part 5  
VDE 0100/0113

Date 14/03/2001

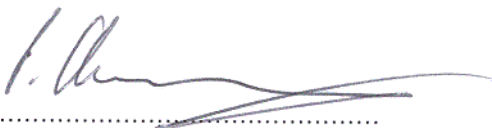
Manufacturer's signature:   
Information on the undersigned: Assistant Manager



## 2 For your safety

### 2.1 General dangers

Used correctly, the machine itself does not pose any danger. Installation or combination with other machinery can, however, present dangers that are unintentional on the part of the manufacturer. We would like to draw your attention to the fact that the user must observe work area guidelines when operating the machine.

### 2.2 Definition

The terms used in these operating instructions correspond to the EN 292-1 / 2.

The in-company technical documentation also corresponds to the EN 292-1 / 2.

### 2.3 Correct use

In order to prevent damage to persons or machinery, the machine may only be operated in accordance with its intended use.

The LABOR-PILOT 2000/4 has a modular design, i.e. the machine can be operated as basic device or can be turned into differently operating devices using modules. The basic device LABOR-PILOT 2000/4 as well as the modules DISPAX-REACTOR<sup>®</sup> DR and Colloid mill MK are designed for dispersing mixtures during the liquid, pumpable phase. Dispersions include the area of emulsions (liquid/liquid), suspensions (liquid/solid), and aerosols (gaseous/liquid).

The device is also suitable for both homogenisation and solution of colloid substances. In order to ensure protection of the machine against foreign bodies such as screws, stones, welding beads etc. on the mixing tools, it is recommended that a sieve or filter is placed in front of the machine prior to feeding in substances.

The LABOR-PILOT including the MHD module is designed for mixing and homogenising liquid substances with powdery substances.

### 2.4 Safety precautions

#### 2.4.1 User's duty of care

The machine (including the subassemblies) has been designed and built considering a danger analysis and after careful selection of the harmonised standards to be observed as well as further

technical specifications. It corresponds to the latest state of the technology and allows for maximum safety during operation.

The safety of machinery, however, can only be realised during operation if all required measures have been taken. It is the user's duty of care to plan these measures and to check their realisation.

The user must especially ensure that:

- the machine is only operated in accordance with its intended use
- the machine is only operated in a technically perfect and operational condition and that in particular the functional reliability of the safety equipment is checked at regular intervals
- required personal protective equipment for operating, maintenance, and repair personnel is available and will be worn
- the operating instructions are always legible and complete at the site of operation of the machine
- the machine is exclusively operated, maintained, and repaired by qualified and authorised personnel
- this personnel, at regular intervals, shall receive instruction regarding all questions concerning work safety and environmental protection and that they are familiar with the operating instructions and in particular with the included safety information
- all safety signs and warnings attached to the machine itself will not be removed and made illegible

#### 2.4.2 Special safety information and symbols used

The following operating instructions give special safety information in order to point to residual risks involved when operating or maintaining the machine that can not be avoided. These residual risks include dangers for

- persons
- product and machine
- environment

The symbols used in these operating instructions are mainly meant to draw the attention to the safety information!



**Danger**

**This symbol indicates that above all dangers for persons must be expected.**

**(Danger of life, risk of injury)**



**Attention**

**This symbol indicates that above all dangers for machine, material, and environment must be expected.**

The most important aim of the safety information is to prevent personal injury.

If the warning triangle with the “Danger” caption is placed in front of a safety instruction, this means that dangers for machine, material, and environment can not be excluded.



If the warning triangle with the “Attention” caption is placed in front of a safety instruction, this means that dangers for persons are, however, not to be expected.  
The respective symbol used can not replace the text of the safety instruction. Therefore, always read the text completely!



Note

**This symbol does not point to safety information, but to information for a better understanding of the sequences of machine operation.**

### 2.4.3 General safety information



Danger

**Modifications of the system and parts of it are only allowed with written approval of IKA. Otherwise the warranty and the declaration of conformity will become void!**



Danger

**If connected to the power supply, the system is live. This voltage may have highly dangerous effects when being touched.**



Note

**Subject to technical modifications.**

### 2.4.4 Basic safety precautions during normal operation



Danger

**Before switching the machine on, inform yourselves about the correct behaviour in case of failures!**



Danger

**The machine may only be operated by trained and authorised persons who are familiar with the operating instructions (also of the subassemblies) and who are able to follow these instructions!**



**Danger**

Replace all hose lines at regular intervals as a preventive maintenance measure, even if no damages can be recognised! (Observe the manufacturers' indications!)



**Danger**

If the working chamber is brought to a specified temperature, above 65 °C the danger of burns exists at the non-insulated parts of the reservoir and the supply lines. In this case, the hot parts must be provided with a touch guard by the user



**Danger**

Make sure that an additional stirrer in the hopper is adjusted to a low speed before switching it on. In case of too high speed adjustments some liquid may spurt out of the hopper in dependence on the filling level when operating with open hopper. Particularly during operation with installed wiping stirrer the lowest speed must be adjusted before operation.



**Note**

The machine is not appropriate for the exclusive supply and treatment of pure dry substances. This may cause serious damages of the device



**Note**

When changing the dispersing material, it should be checked if the material of the rotary shaft seal and the O-rings is still suitable. It may be necessary to replace the parts against parts made of other materials.

In case of doubt, please contact your supplier or the IKA plants directly.



**Note**

After the assembly work is completed and before the drive is switched on, check the clearance of the machine's drive shaft by manually turning it.

In doing so, protect the drive against inadvertent starting!



**Note**

The machine is not suitable for processing abrasive substances. Abrasive substances cause early wear particularly of the rotary shaft seal which may lead to undesired product leakage.

### 2.4.5 Basic safety precautions during service and maintenance



**Danger**

The machine may only be maintained by qualified and authorised persons observing the safety information and who are familiar with the operating instructions (also of the sub-assemblies) and who are able to follow these instructions!



**Danger**

Before any maintenance and repair work switch off the main switch of the power supply and lock it with a padlock! The key of this lock must be with the person carrying out the maintenance or repair work!



**Danger**

Before any maintenance and repair work ensure that all parts of the machine that must possibly be touched have cooled down to ambient temperature!



**Danger**

Before carrying out any maintenance or repair work close the access to the work area of the machine for unauthorised persons! Attach or erect a sign that draws the attention to the maintenance or repair work!



**Danger**

Observe the inspection and maintenance intervals prescribed by the operating instructions!  
Observe the maintenance and repair instructions of the sub-assemblies included in these operating instructions!



**Danger**

Ensure proper disposal of environmentally hazardous lubricating, cooling or cleaning agents!



**Note**

The pressing screw (730) should be screwed hand-tight and then be tightened with a tightening torque of approx. 17 Nm. It is recommended to additionally lock the thread with a liquid but with normal tools detachable screw locking (e.g. LOCTITE).

### 2.4.6 Work on the electrical equipment



**Attention**



**Danger**

Connection of the device must correspond to VDE standards. The connection to the power supply must be realised in accordance with the indicated data, such as rated voltage, rated frequency, rated current, and maximum fuse protection. The motor rating can be found on the motor rating plate or the technical data sheet.

- Repair work on the electrical equipment of the machine may only be carried out by a skilled electrician!
- Check the electrical equipment at regular intervals!
- Tighten loose connections again!
- Immediately replace damaged lines/cables!
- Always keep the control cabinet closed! Access only for authorised persons with key/tool!
- Never clean control cabinets and other housings of the electrical equipment using a water hose!

### 2.4.7 Observe the environmental protection regulations



**Danger**

During any work at and with the machine the legal obligations concerning waste avoidance and proper recycling/disposal must be observed

Especially during installation, repair, and maintenance work substances being hazardous to water such as

- lubricating greases and oils
- coolants
- solvent-based cleaning liquids

may not contaminate the soil or get into the sewage system! These substances must be stored, transported, and disposed in suitable containers!

## 2.5 Other dangers

The machine has been designed in such a way that neither the machine itself nor its accessories may present any danger to persons, products or the environment. The operating instructions have been drawn up in such a way that no dangers should arise if the warnings and maintenance guidelines are observed.

It is, however, impossible to rule out danger sources attributable to human error.



No other risks are to be anticipated upon proper use of the device and consideration of the recommendations and guidelines in accordance with the regulations governing the prevention of accidents and the employer's liability insurance associations.

### 3 Description of the LABOR-PILOT 2000/4

#### 3.1 Before using the LABOR-PILOT

After unpacking the device, check the following items, and the number and completeness in accordance with your order.

- Does the type designation and serial number on the rating plate correspond to your order ?
  - Has the LABOR-PILOT 2000/4 been damaged during transport, have some screws loosened ?
- Should the indicated data not correspond to your order, please contact us immediately.

#### 3.2 Description of the device

##### 3.2.1 Description of the main unit and of the attached notes

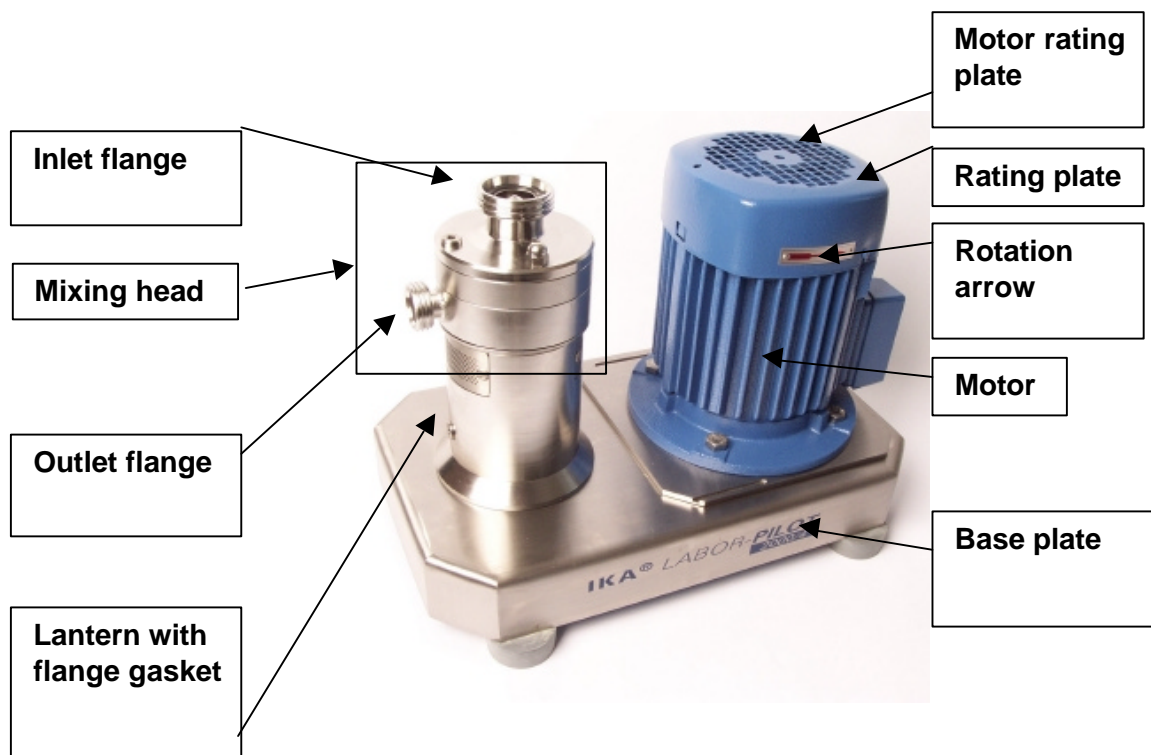

During cleaning of the machine, please make sure not to destroy signs and labels using solvents or to make them illegible.

### **Motor**

The transmission of power from the motor (100) to the drive shaft (426) and the dispersing tools (904) is performed by a sufficiently dimensioned belt drive. The drive shaft is separately supported in the lantern. The motor is mounted on a movable base plate (210) so that the V-belt can be tensioned.

### **Base plate**

The base plate ensures that the device is set up safely on the floor. In order to achieve an isolation between machine and floor the equipment is installed on adjustable rubber feet.

### **Lantern with flange gasket**

In order to seal the pump housing (710) against the drive shaft (426), a rotary shaft seal (501) is integrated in the flange gasket (500).

### **Mixing head**

The mixing head consists of the inlet socket ( 704 ), the pump housing ( 710 ) as well as a mixing tool. Depending on the current module, this mixing tool can be replaced by other mixing tools. According to the module, the mixing heads have different designs. Each module is equipped with independent mixing tools and chambers.

In case of the basic device the stationary part of the mixing tool, i.e. the stator, is double-walled and simultaneously designed as housing of the dispersion chamber. All other modules, such as DISPAX-REACTOR<sup>®</sup> DR, MHD, colloid mill MK, are as well equipped with a standard double casing.

The double casing is suited for heating or cooling of the dispersion housing. Appropriate tempering media can be fed in or discharged at the two connections G 1/8". Appropriate tempering media are e.g. water, heat-transfer oil, steam.

### **3.2.2 Electronic control**

The electronic control of the basic device is realised by a switch mounted on the motor. The switch includes a motor protection switch for overload monitoring, an undervoltage release for protection against restarting after a voltage breakdown and the emergency stop switch.

The optional controller is a separate device being connected to the motor using a 1.5 m long cable.

### 3.3 Principle of operation

#### 3.3.1 Modular design

The basic version of the LABOR-PILOT is a single-stage, high-quality, and multipurpose dispersion device for continuous dispersion of liquids.

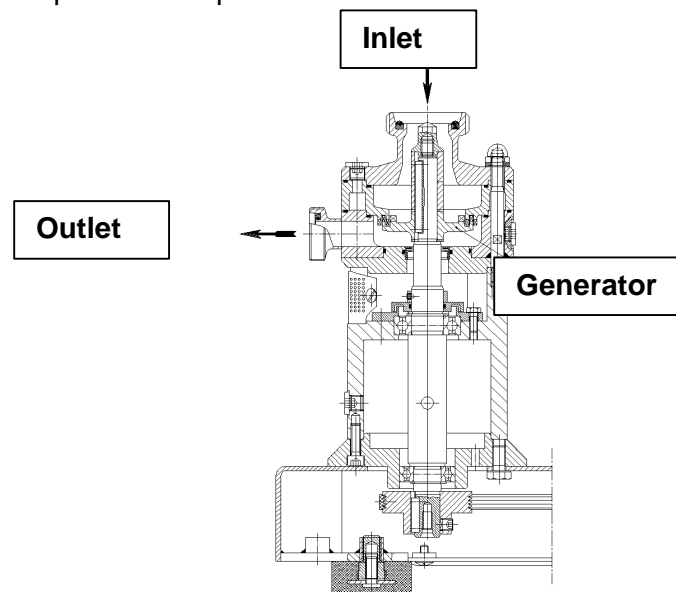

The LABOR-PILOT has a modular design. In its basic version, the LABOR-PILOT will be delivered ready for connection. Optionally, it can be converted into the following devices using the modules listed below:

- Module DISPAX-REACTOR® DR : Extension stage for the three-stage dispersing machine
- MHD module : Extension stage for mixing and dispersion of powdery substances in liquids
- Colloid mill MK module : Extension stage for the colloid mill

The conversion is described in chapter 9. The conversion from the basic version into one of the modules is mainly limited to changing the product-contacting parts. The following parts are equal for all modules and need not be modified:

- The complete drive with the motor, the belt drive, and the base plate
- The lantern with the shaft, the shaft bearing, and the rotary shaft seal
- The product outlet case with the outlet socket



### 3.3.2 Principle of operation of the basic device

The basic device is a single-stage high-performance instrument for continuous dispersion of liquids. Single-stage dispersing instruments are also known at IKA Plants under the trade name ULTRA-TURRAX<sup>®</sup> INLINE or abbreviated UTL. Thus, the LABOR-PILOT is especially suitable for scale-up purposes to larger production machines particularly of the Inline 2000 series.

The dispersing action is based on the rotor-stator principle, which means that a high-speed rotor with very narrow slots rotates in a stator. This produces high shearing energies between rotor and stator. The system consisting of rotor and stator is also called generator. With the help of differently fine-toothed generators the device can be adapted to the respective dispersing task. The different generators must always be used in pairs. Rotors and stators with differently fine-toothed generators must not be combined with one another, as this might damage the device.

The device is not self-priming, however, it can build up a pressure at the outlet and thus overcome a certain lift. The lift depends on the tool used and the speed.

A standard three-phase a.c. motor powers the drive at 3000 rpm and protection category IP55. The transmission ratio of the belt drive increases the speed of the rotor shaft to 7900 rpm. The circumferential speed at the periphery of the rotor given this speed is 23 m/s.

Optionally, the speed of the LABOR-PILOT can be adjusted with the LABOR-PILOT CONTROLLER. The adjustable speed ranges from 3160 rpm to 13750 rpm. The maximum circumferential speed at the periphery of the rotor is reached at the highest speed and is approx. 40 m/s. As the circumferential speed of the rotor has a decisive influence on the dispersion result, the LABOR-PILOT CONTROLLER offers an excellent possibility to adapt the device to the processing requirements.

**Generator – pumping stage  
2P**



**Generator, coarse-  
toothed 2G**



**Generator, medium-  
toothed 4M**



**Generator, fine-  
toothed 6F**



### 3.3.3 Principle of operation of the Module DISPAX-REACTOR<sup>®</sup> DR

The LABOR-PILOT with the module DISPAX-REACTOR<sup>®</sup> in contrast to the basic device is a three-stage dispersing instrument with three generators being installed one after the other. This multistage arrangement of rotor-stator-systems makes it possible to answer maximum requirements on homogenisation and dispersion of emulsions and suspensions. With the help of differently fine-toothed generators the device can be adapted to the respective dispersing task. The generators can be combined in any order, but the coarser-toothed generators should be installed towards the inlet.

The device is not self-priming, however, it can build up a pressure at the outlet and thus overcome a certain lift. The lift depends on the tool used and the speed. The three-stage device achieves a higher lift than the single-stage basic device.

Like the basic device, the speed of LABOR-PILOT with the module DISPAX-REACTOR<sup>®</sup> can optionally be adjusted using the LABOR-PILOT CONTROLLER. The adjustable speed ranges from 3160 rpm to 13750 rpm. The maximum circumferential speed at the periphery of the rotor is reached at the highest speed and is approx. 40 m/s. As the circumferential speed of the rotor has a decisive influence on the dispersion result, the LABOR-PILOT CONTROLLER offers an excellent possibility to adapt the device to the processing requirements.

In case of certain generator combinations, particularly in case of the combination with three fine-toothed generators 6F6F6F, and in dependence on the product to be mixed, the power limit can be reached at very high speeds. Nevertheless, the rated current of the motor should not be exceeded for a longer period. If necessary, the speed must be reduced to such an extent that the rated current of the motor will just not be exceeded. The rated current can be read at the display of the LABOR-PILOT CONTROLLER. In case of an overload of the motor, it will be switched off by activating a thermal motor protection.

### 3.3.4 Principle of operation of the MHD module

The LABOR-PILOT with the MHD module is a high-quality, multipurpose mixing device for continuous mixing of solid substances with liquids. Both the solid and the liquid component must be proportioned into the device at the respective inlet socket. In the device itself, the components are intimately mixed, dispersed or homogenised and are discharged from the device via an outlet socket.

The controlled feeding of the liquid and the solid component results in a final product with proportional quantities, the exactness depending on the feeding devices. Feeding can be realised using e.g. the following devices:

	<b>Proportioning device</b>	<b>Remark</b>
<b>Proportioning of the solid component</b>	Volumetric proportioning screw	Reduced expenditure, varying proportioning accuracy
	Gravimetric ratio weigher	High expenditure, high proportioning accuracy
<b>Proportioning of the liquid component</b>	Eccentric screw pump	Simple, not suitable for all products
	Rotary-piston pump, gear pump	High expenditure, suitable for most products

The MHD module can build up a pressure on the outlet side and thus overcome a certain lift. The lift depends on the tool used and the speed.

#### Mixing tools

The mixing tools of the machine are located above the rotary shaft seal on the drive shaft. All the tools can be dismantled individually and thus an optimum adaptation to the set process goal is possible. Their task is to bring the fed mixing components in contact with each other, to mix them intimately, and to discharge the mixed product from the machine.

The tools used differ in dependence on the mixing zone. They are mounted on the drive shaft one after the other and are fixed by the topmost tool. This topmost tool is designed as a screw. The screw is located in the area of the solids inlet and has the following tasks:

- Take the solid substance in the premixing chamber
- Clear the solids inlet area from possible caking
- Cut the "wet" premixing area off of the "dry" solids area

The tools of the premixing area are located below the screw. In this zone, the solid and the liquid component get in touch with each other. With their high speeds the tools cause a strong turbulence and thus the mixing of the substances as well as a transport into the next chamber downwards.

The lowest chamber houses a centrifugal impeller. Depending on the application, this can be designed purely as a pump wheel or an additional dispersing stage together with a stator can be installed. The types 2P, 2G, 4M can be used as generators. The generator 6F can not be used for the

MHD module.

### **Premixing chamber**

In the premixing chamber, the components to be mixed get in touch with each other. It consists of a casing with a central liquid connection and an exchangeable injector jacket. It is fixed by the solids inlet socket. The liquid component is fed into the central connection under pressure, distributes in the space between casing and injector jacket and will then be injected into the premixing area via the openings of the injector jacket.

### **Pump housing**

The pump housing is located below the premixing chamber. A stator and thus an additional dispersing stage can be installed optionally here. The product to be mixed is radially accelerated by the rotating impeller and discharged via the outlet socket.

Like the basic device, the speed of the LABOR-PILOT with the MHD module can optionally be adjusted using the LABOR-PILOT CONTROLLER. The adjustable speed ranges from 3160 rpm to 13750 rpm. The maximum circumferential speed at the periphery of the rotor is reached at the highest speed and is approx. 40 m/s. As the circumferential speed of the rotor has a decisive influence on the dispersion result, the LABOR-PILOT CONTROLLER offers an excellent possibility to adapt the device to the processing requirements. Operation with the MHD module should first be started at the standard speed of 7900 rpm, and all further optimisations should be realised on the basis of this speed.

### **3.3.5 Principle of operation of the Colloid mill MK module**

The LABOR-PILOT with the colloid mill MK module is a high-performance colloid mill incl. a grinding gear, which, like the basic device, is designed according to the rotor-stator-principle. However, the grinding gear design differs considerably from that of the basic device. The grinding gap between rotor and stator has a conical design and allows a continuous adjustment of the grinding gap by means of axially displacing the stator. This grinding gap adjustment enables an optimum adaptation of the device for the production of stable emulsions and finest particles during wet milling.

The grinding gap is adjusted manually using an adjusting ring on the outside of the housing. The grinding gear has a standard longitudinal toothing and is made up of two parts, i.e. both the rotor and the stator consist of two stages in tandem arrangement with different fine toothings each. The first stage has a slightly coarser toothing and is provided with a special feed zone. The second stage has a very fine toothing.

The device is not self-priming, however, it can build up a pressure at the outlet and thus overcome a certain lift. The lift depends on the adjusted grinding gap and the speed.

Like the basic device, the speed of the LABOR-PILOT with the colloid mill MK module can optionally be adjusted using the LABOR-PILOT CONTROLLER. The adjustable speed ranges from 3160 rpm to 13750 rpm. The maximum circumferential speed at the periphery of the rotor is reached at the



highest speed and is approx. 40 m/s. As the circumferential speed of the rotor influences the milling result, the LABOR-PILOT CONTROLLER offers an additional possibility to adapt the device to the processing requirements. Operation with the colloid mill MK module should first be started at the standard speed of 7900 rpm, and all further optimisations should be realised on the basis of this speed.

In case of certain products or product characteristics, e.g. high viscosity, especially the power limit of the device can be reached at very high speeds. Nevertheless, the rated current of the motor should not be exceeded for a longer period. If necessary, the speed must be reduced to such an extent that the rated current of the motor will just not be exceeded. The rated current can be read at the display of the LABOR-PILOT CONTROLLER. In case of an overload of the motor, it will be switched off by activating a thermal motor protection.

### 3.4 Dimensions

#### 3.4.1 Figure 1 Dimension sheet

LABOR-PILOT 2000/4 with motor protection switch

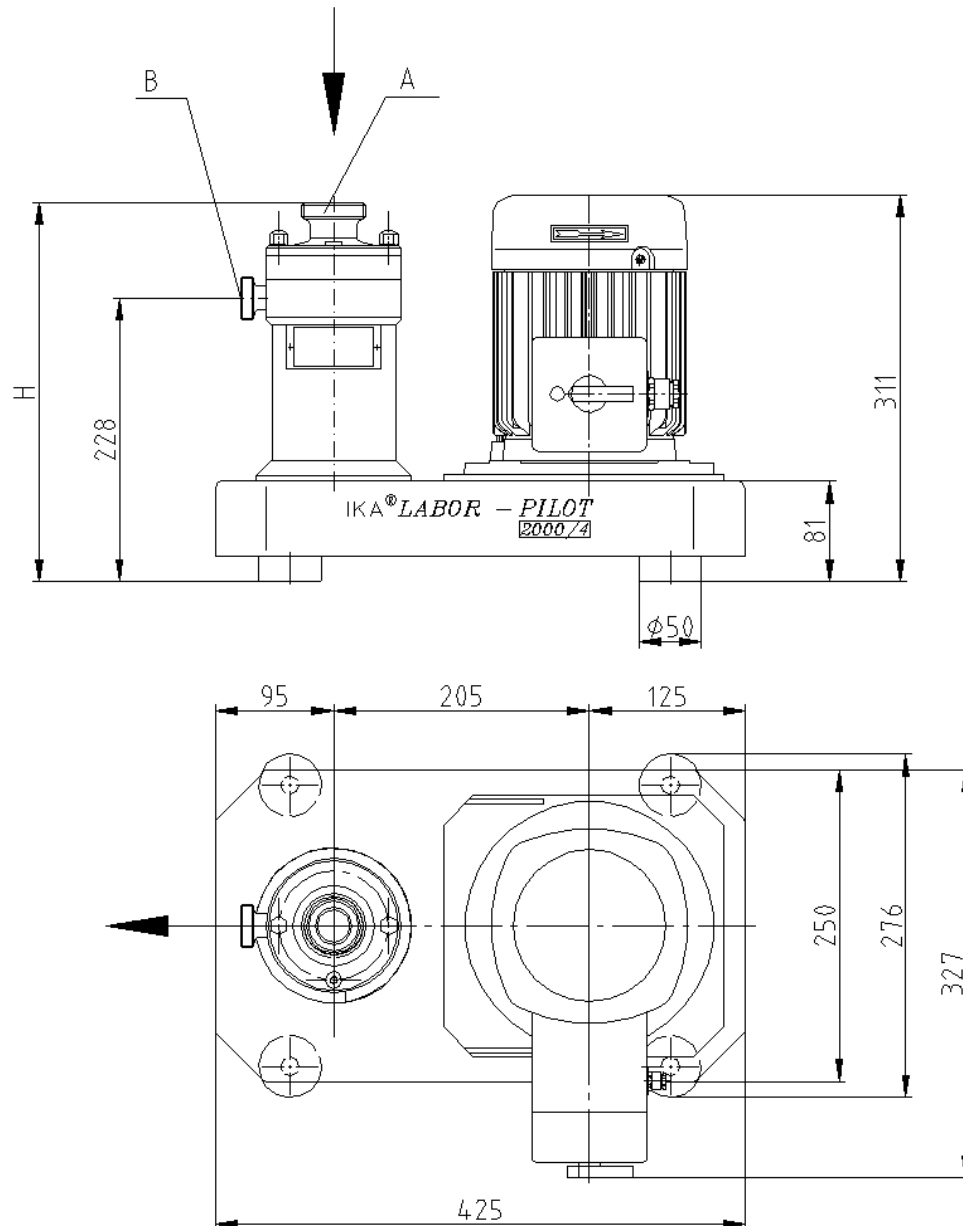

3.4.2 Figure 2 Dimension sheet

LABOR-PILOT 2000/4 for operation with LABOR-PILOT CONTROLLER

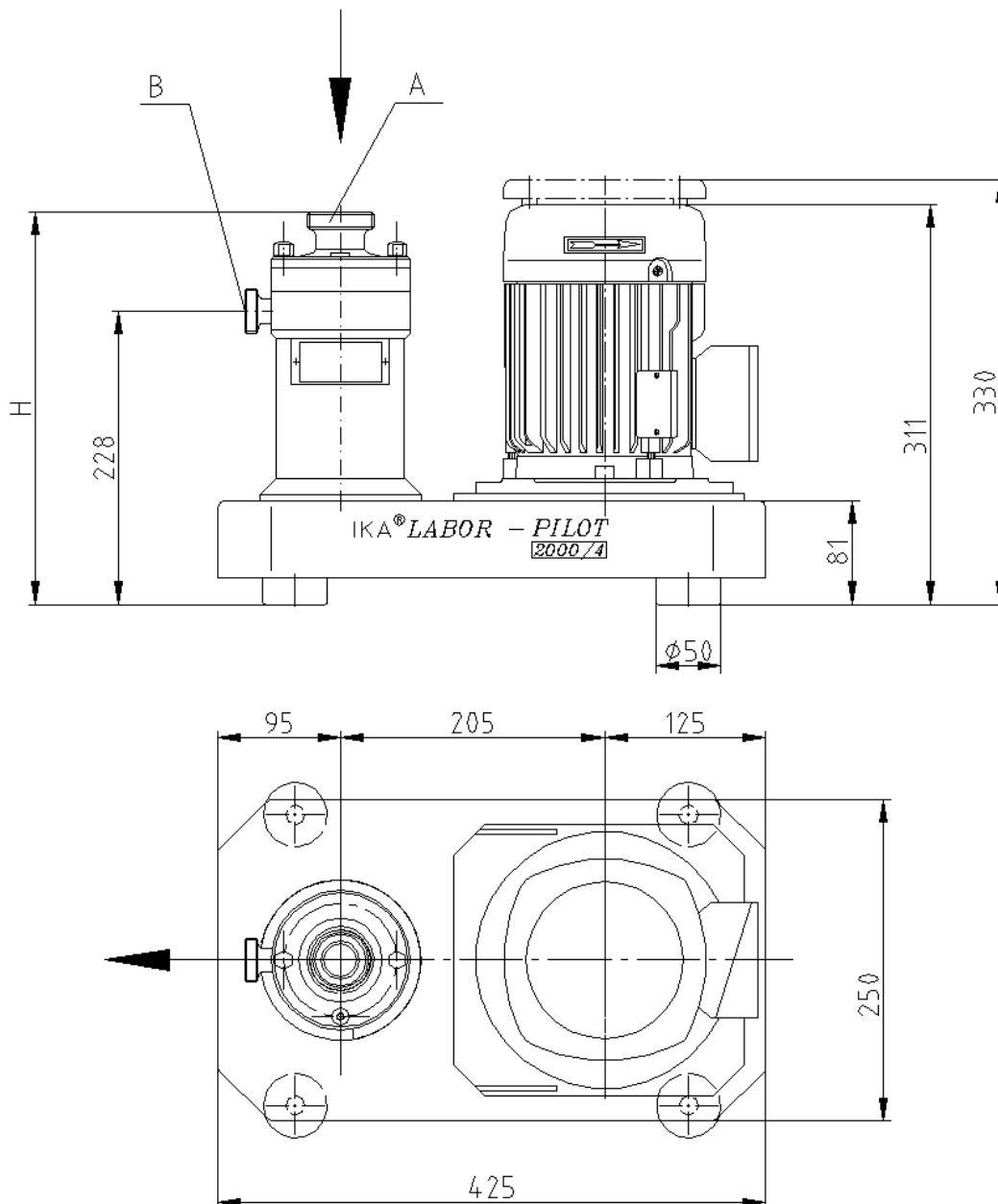

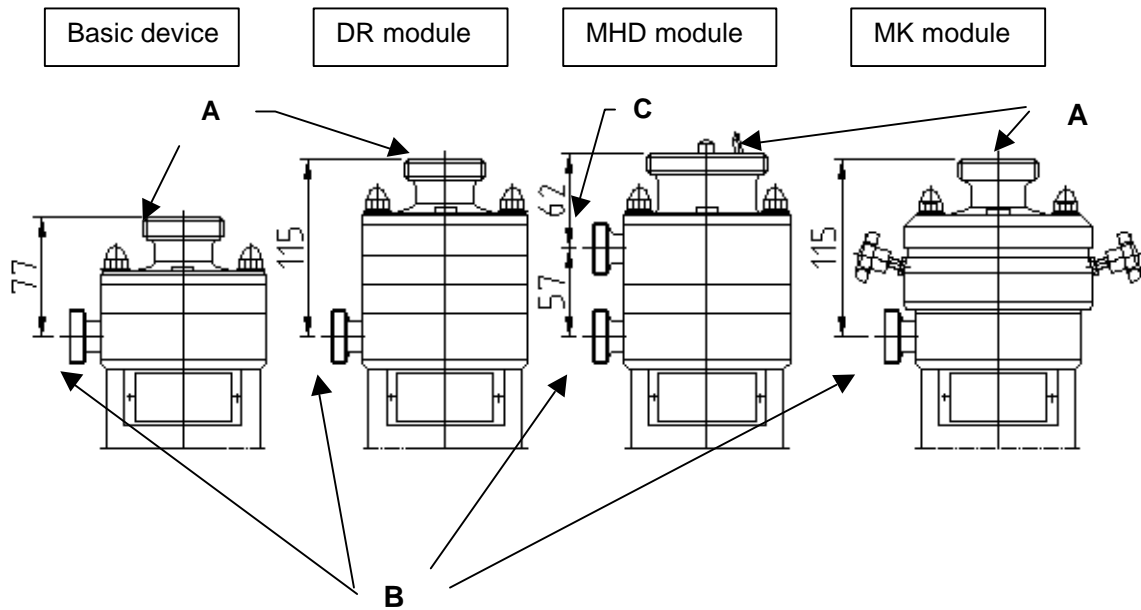

**3.4.3 Figure 3 Dimension sheet**

**3.4.4 Dimension table**

See also figures 1, 2, and 3

Modules	A Inlet	B Outlet	C Liquid on	H Height in mm
Basic device LABOR-PILOT 2000/4	DN 25	DN 15	-	305
Module DISPAX-REACTOR® DR	DN 25	DN 15	-	343
MHD module	DN 50	DN 15	DN 15	347
Colloid mill MK module	DN 25	DN 15	-	343

## 4 Specifications

### 4.1 LABOR-PILOT

#### Operation as basic device without speed regulation

Rotor speed (60 Hz)	:	7900 rpm
Sound pressure level	:	73 dB(A)

#### Operation with speed regulation at the LABOR-PILOT CONTROLLER

Rotor speed (24 – 105 Hz)	:	3160 – 13750 rpm
Max. sound pressure level	:	83 dB(A)

#### Other general data

Max. permissible product temperature	:	120 °C
Max. permissible operating overpressure	:	3 bar
Max. permissible temperature of double casing	:	120 °C
Max. permissible operating overpressure of double casing	:	2 bar

#### Max. throughput rates

The values apply to the standard speed of 7900 rpm, water 20 °C, the throughput rates increase almost linearly with the speed

Basic device, single-stage, generators 2G, 4M, 6F	:	approx. 350 liters/h
Basic device, single-stage, generator 2P (pump stage)	:	approx. 3500 liters/h
Module DISPAX-REACTOR® DR	:	approx. 350 liters/h
Colloid mill MK module	:	approx. 300 liters/h
MHD module, total quantity	:	approx. 100 liters/h

#### Materials

Product-contacting parts	Stainless steel 1.4571 / 316 Ti
Lantern, frame	Stainless steel
Rotary shaft seal	PTFE Compound
Elastomeric working chamber (only standard version)	FPM (Viton)

## 4.2 Electrical system

### 4.2.1 Motor:

#### General

Operating voltage (depending on the version)	:	3 x 240/460V / N / PE
Frequency	:	60 Hz
Capacity	:	2HP
Motor speed (60 Hz)	:	3600 rpm
Protection category	:	IP 55
Insulation class	:	F
Explosion protection	:	none
with thermocouple, suitable for frequency converter operation	:	24 - 105 Hz

#### Mains power supply

Supply line	:	Supplied by customer
Mains voltage	:	3 x 230 V + PE / $\pm 10$ %
Mains frequency	:	60 Hz
Max. distortion of the supply voltage	:	$\pm 2.0$ % of the rated supply voltage
Power factor (400 V) / $\cos. \varphi$	:	0.9 / 1.0 given rated load
Switching actions at the supply input	:	2 x / min
Max. fuse protection	:	16 A, class B characteristics, circuit-breaker for overcurrent protection (IEC898)

#### Connection cable:

Motor cable	:	3 m, oil-resistant cable with integrated thermistor line, connected ready for use
-------------	---	---

#### Environment:

Housing	:	Stainless steel
Protection category	:	Front IP 55, back IP 53
Dimensions	:	W x H x D = 210 x 380 x 300 mm
Ambient temperature	:	10 – 35 °C
Max. relative humidity	:	5 % - 85 % during operation
Atmosphere	:	Must be free from aggressive liquids, particles, and gases which might damage or impair the electronic parts
Max. height above sea level	:	1000 m

**EMC:**

Interference voltage (conducted emission at the mains connection)	:	DIN EN 50 081-1	:	EN 55011-1 B
Interfering field strength (emission level)	:	DIN EN 50 081-1	:	EN 55011-1 B
Immunity	:	DIN EN 50 081-2	:	EN 61000-4-2/3/4/5/6

**Speed regulation:**

Rated speed of motor	:	7900 rpm (60 Hz)
Speed control range	:	3160 – 13750 rpm (24 – 105 Hz)
Increment	:	106.2 rpm (0.67 Hz)

**Motor current measurement:**

Motor current measuring range	:	0.00 - 6.00 A
Accuracy of motor current measurement	:	+/-

**Temperature measurement:**

Temperature measuring range	:	0 – 200 °C
Accuracy of temperature measurement	:	+/- 1 °C

**Timer function:**

Time range	:	0 – 120 min
Discrimination	:	1 min

**4.2.2 LABOR-PILOT CONTROLLER**

Operating voltage (depending on the version)	:	3 x 220-240V / N / PE
Frequency	:	60 Hz
Power output	:	2HP
Ambient temperature	:	10 - 35 °C
Output frequency range	:	24 - 105 Hz
Temperature indicator	:	0 - 200 °C
Explosion protection	:	none

The LABOR-PILOT CONTROLLER consists of a stainless steel housing complete with frequency converter, speed indicator, temperature indicator, timer, clear text display with language selection, adapter DN 15 with thermosensor Pt 100 at the product outlet

→ refer to special description in chapter 6.2 !

### 4.2.3 Power supply / Cable

The device will be delivered without an input power connection. It is the customer's responsibility to have a qualified electrician make the input power connection. It is recommended that a 4-conductor cable, of correct wire AWG, be connected through the liquid tight hub, located on the rear panel, into the 3-pole fuseblock. On the input side, the device is connected for a clockwise rotating field as a standard. → refer to brief test!

## 4.3 Dimensions and weights of LABOR-PILOT 2000/4:

See also figure 1 to 3

These indications relate to a standard device with a 2HP drive motor.

Height	:	approx. 319 mm
Length	:	approx. 464 mm
Width	:	approx. 250 mm
Weight of LABOR-PILOT 2000/4	:	approx. 36 kg
Weight of LABOR-PILOT CONTROLLER	:	approx. 17 kg

## 5 Installation

### 5.1 Mounting and alignment of the machine

The machine can be mounted freely with the base plate.

The machine must be mounted on even ground. The machine base must be aligned horizontally using a spirit level along its longitudinal and transverse axis. For levelling, the rubber feet (item 204) at the base plate can be height-adjusted. The rubber feet are self-locking and must not be additionally secured after adjustment.

### 5.2 Product connections

The LABOR-PILOT 2000/4 including the modules DISPAX-REACTOR® DR and Colloid mill MK can either be operated using circulation or flow-through processes.

The corresponding accessories for the respective operating modes can be supplied by IKA Plants.

#### 5.2.1 Connection size at the inlet and outlet socket

The LABOR-PILOT is equipped with screwed pipe connections acc. to DIN 11851 (milk pipe fitting) for product supply and discharge. The nominal widths of the basic device and the individual modules can be found in the following table:

Modules	Inlet socket	Inlet socket Powder	Inlet socket Liquid	Outlet socket
Basic device LABOR-PILOT 2000/4	DN 25	-	-	DN 15
Module DISPAX-REACTOR® DR	DN 25	-	-	DN 15
MHD module	-	DN 50	DN 15	DN 15
Colloid mill MK module	DN 25	-	-	DN 15

### 5.2.2 Operation using flow-through processes

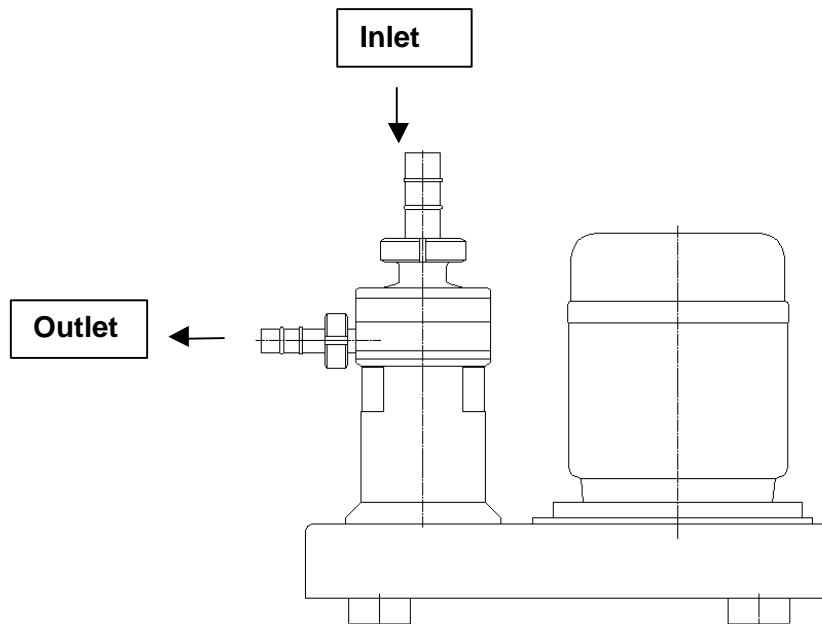

If the hose connectors, which can be delivered as accessories, are screwed to the inlet and outlet, it is possible to connect corresponding hoses for product supply and discharge. Pay attention that the hoses are securely clamped at the hose connectors. Exclusively use hoses that are compatible with the product and show a sufficient pressure, temperature, and media resistance.

5.2.3 Accessories for operation using circulation processes

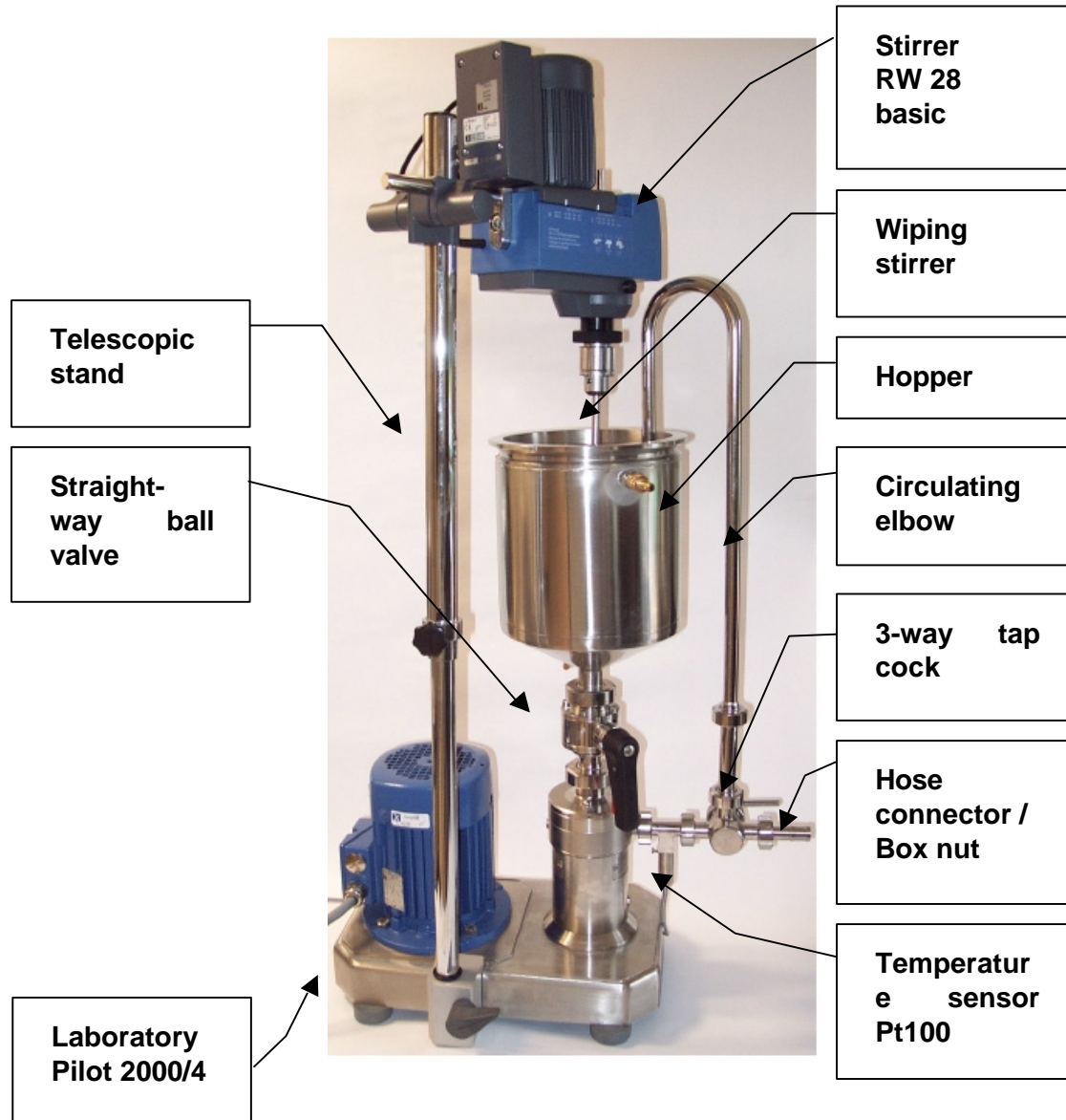

The accessories, which can be delivered by the IKA Plants, can be mounted to the LABOR-PILOT according to the dimension drawing. Instead of the wiping stirrer shown it is also possible to use other stirring tools, such as propeller stirrer, turbine stirrer etc., depending on the product quality



### 5.2.3.1 Circulation pipe

As far as the circulating elbow is concerned pay attention that, when using the wiping stirrer, the lower edge of the outlet is at least 5 mm above the upper edge of the wiping stirrer. For this a straight extension is delivered which must be mounted between the 3-way tap cock and the outlet elbow.

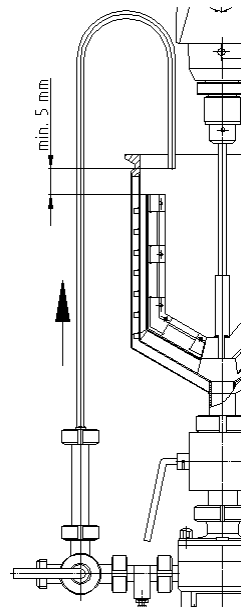

If the wiping stirrer is not used or another stirring tool is used, the intermediate piece is not necessary. However, always pay attention that the stirring tool can definitely not touch the outlet elbow.

### 5.2.3.2 Telescopic stand leg

The telescopic stand leg is fixed at the base of the LABOR-PILOT using a clamping piece:

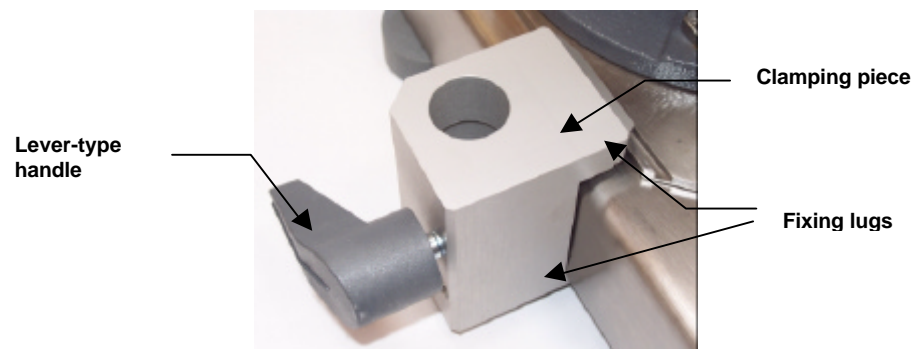

- The telescopic leg must be securely screwed to the clamping piece.
- Push the clamping piece with the two fixing lugs into the groove on the motor base plate and into the groove on the bottom of the plate.
- Align the clamping piece vertically using the adjusting screw
- Firmly tighten the clamping lever

- Check that the fastening is free from play and secure

### 5.2.4 Connection on the suction side

If the accessories provided by the IKA Plants are not used or the machine is permanently piped, pay attention that the pipework does not exert any additional load on the machine.

The following items have to be observed:

- The suction side should be designed as a free inlet if possible. The piping should be as short as possible and fitted with few elbows. Provide suitable supports and flexible connections in order to keep the machine free of loads exerted by the pipework.
- If the suction side is not designed as a free inlet, provide a prefilling unit.
- Carefully realise the connections on the suction side and avoid leakage.
- Avoid unfavourable conditions on the suction side, e.g. long piping, high suction height etc.
- Absolutely avoid any inclusion of air. The supply line must be laid rising towards the machine, and falling in case of inlet.
- Do not dimension the suction pipe smaller than the suction connection.

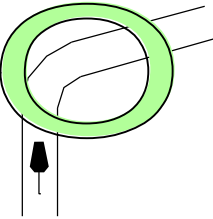
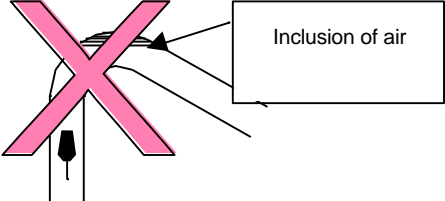
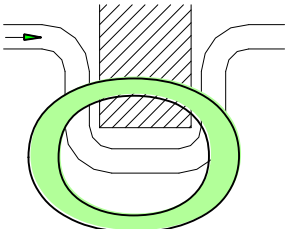
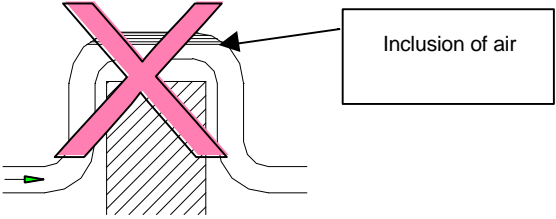
Optimum conditions	Unsuitable conditions
	
	

### 5.2.5 Connection on the delivery side

If the accessories provided by the IKA Plants are not used or the machine is permanently piped, pay attention to the following.

- Keep the machine free of loads exerted by the pipework. Provide suitable supports and flexible connections for this.
- If the pipework is too long, the resistance of the pipework increases and the performance data of the machine change. The pipework diameter should be selected considering the resistance of the pipework.
- To be able to adjust the delivery volume later, it is advisable to install a control valve on the delivery side, e.g. a ball valve, flap valve.
- A pressure gauge preceding the control valve as near as possible to the outlet is useful.
- In case of long horizontal delivery lines, a ventilation possibility should be provided.
- The installation of non-return devices and shut-off elements is especially useful with long pipework.
- Before commissioning, containers, pipework, and connections must be thoroughly cleaned and rinsed, so that during operation no welding beads, scale or other impurities can loosen and damage the machine or other system parts.

### 5.2.6 Connection of the MHD module

The machine has three connections for product pipes.

The vertical connecting sleeve for the solids supply is located in the upper section of the machine. Here, the connection of a volumetric or gravimetric proportioning screw must be realised. The central connection for the liquid mixing component supply is located in the casing. The connection is situated at the side of the casing. Here, the delivery line of a delivery pump or a proportioning unit for the liquid must be provided. When installing pipework, observe the items mentioned under "5.2.4 Connection on the suction side".

The connection for the product discharge is located in the pump housing. When installing pipework, observe the items mentioned under "5.2.5 Connection on the delivery side".

#### Installation example LABOR-PILOT with MHD module

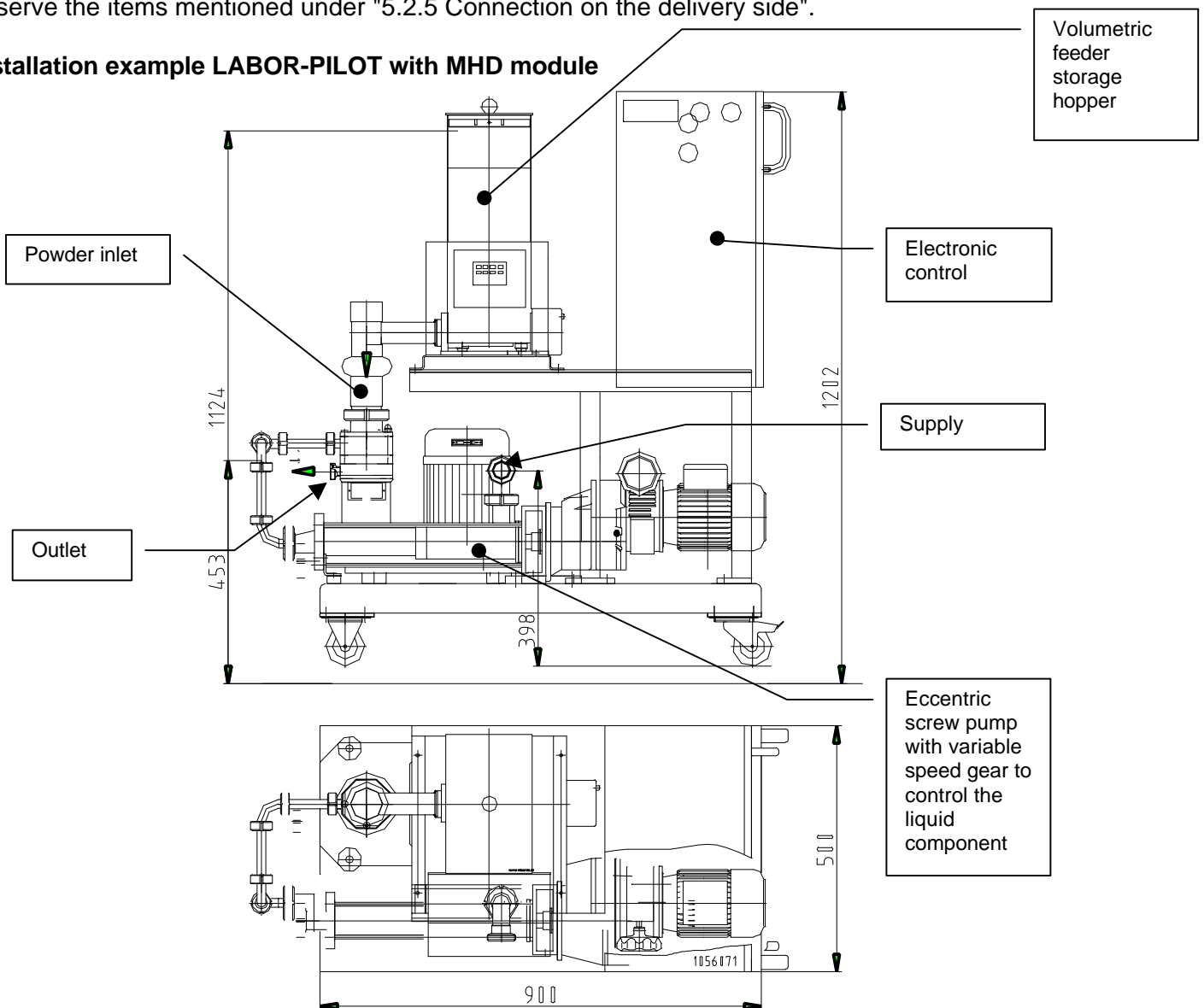

### 5.3 Heating/Cooling connections

The basic device as well as all other modules are additionally equipped with heating/cooling connections in the form of female threads G 1/8. One connection each is located in the inlet cover and one in the outlet chamber. They are protected with a standard closing plug, and in case of need they can be connected to suitable heating or cooling devices via hose lines using suitable screwed pipe connections. Appropriate tempering media are e.g. water, heat-transfer oil, and steam.

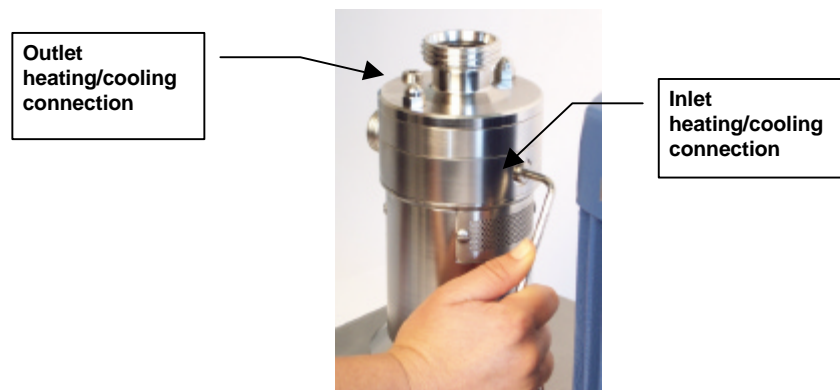

**Danger**

If the working chamber is brought to a specified temperature, above 65 °C the danger of burns exists at the non-insulated working chamber and the supply lines. In this case the hot parts must be provided with a touch guard by the user.



**Note**

The permissible temperature range in the double casing is 10 up to 120 °C. The permissible pressure of 2 bar must not be exceeded.

## 5.4 Voltage supply

Refer to Appendix Electrical description



**Attention**

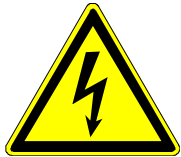

**Danger**

The electrical connection of the device must be made in accordance with local and building codes and comply with all applicable regulatory standards.

The incoming electrical power must be compatible with the motor data, such as rated voltage, rated frequency, rated current, and maximum fuse protection. The motor rating can be found on the motor rating plate, technical data sheet or consult the manufacturer.

- Use only a qualified electrician to carry out repair work on the electrical equipment of the machine!
- Check the electrical equipment at regular intervals!
- Tighten loose connections again!
- Immediately replace damaged lines/cables!
- Always keep the control cabinet closed! Access only for authorized persons with key/tool!
- Never clean control cabinets and other electrical equipment using a water hose!



## 6 Operation

### 6.1 Operating the machine without LABOR-PILOT CONTROLLER

#### 6.1.1 Operating controls

It is the customer's responsibility to provide the electrical controls to operate the machine. At a minimum an on/off switch with emergency-stop function should be connected in the incoming power to turn the drive motor on and off. Have a qualified electrician determine the proper controls and wire needed to meet all national, local and building codes. Electrical safety must be followed to keep the user safe.

#### 6.1.2 Optional controls

To vary the speed of the motor a Variable Frequency Drive (VFD) may be purchased and installed. Always follow the manufacturers instructions for proper installation.

-or-

Purchase a Process Controller from IKA Works to control the machine as described in the following section.



## 6.2 Operation of the LABOR-PILOT Controller

After unpacking the device, check the following items, and the number and completeness in accordance with your order.

- Does the type designation and serial number on the rating plate correspond to your order?
  - Has the LABOR-PILOT 2000/4 been damaged during transport or have some screws loosened?
- Should the indicated data not correspond to your order, please contact us immediately.

### 6.2.1 Abbreviations:

The following abbreviations are used throughout the text:

- HMI = Controls and displays (Human Machine Interface)  
 FC = Frequency converter (controls the motor)

### 6.2.2 Design:

The controller is housed in a separate control cabinet, which will be installed separately. The inter-connection lines between controller and drive motor are hardwired to the machine. The temperature measuring line can be plugged in at the controller.

The controller utilizes a VFD (Variable Frequency Drive), which provides adjustable speed control of the Labor Pilot®.

### 6.2.3 Controller speed range:

The controller can be adjusted from 24Hz to 105Hz for a shaft speed range of 3160RPM to 13750RPM.

The following chart specifies the speed range to operate each module. It is recommended that you operate within these specifications. Exceeding these ranges may result in mechanical failure.

Module	SHAFT/RPM	Hz	MOTOR/RPM	M/sec.
MK	3160-7900	24-60	1440-3600	8.5-23
MHD	3160-7900	24-60	1440-3600	8.5-23
UTL	3160-7900	24-60	1440-3600	8.5-23
DR	3160-7900	24-60	1440-3600	8.5-23
DRS	3160-13750	24-105	1440-6300	8.5-40

All IKA® 2000 machines are designed to operate at rotor tip speed of 23m/sec at 60Hz from this size through all production models. The speed can be reduced if process conditions require it. The DRS is the only exception. It is designed to operate at a rotor tip speed of 40 m/sec when maximum energy input is required.

Please consult IKA with any questions regarding the application.

**Note:** The speed value shown on HMI display indicates the shaft speed.



## 6.2.4 Installation



**Attention**



**Danger**

The electrical connection of the device must be made in accordance with local and building codes and comply with all applicable regulatory standards.

The incoming electrical power must be compatible with the motor data, such as rated voltage, rated frequency, rated current, and maximum fuse protection. The motor rating can be found on the motor rating plate, technical data sheet or consult the manufacturer.

- Use only a qualified electrician to carry out repair work on the electrical equipment of the machine!
- Check the electrical equipment at regular intervals!
- Tighten loose connections again!
- Immediately replace damaged lines/cables!
- Always keep the control cabinet closed! Access only for authorized persons with key/tool!
- Never clean control cabinets and other electrical equipment using a water hose!

### Power Supply Connection

After determining the proper wiring requirements, run the incoming power cable through the seal-tight fitting located on the rear panel of the controller. Connect the corresponding leads to L1/L2/L3 terminals of the fuseblock. (refer to wiring diagram) It will be necessary to remove the fuse covers to access the terminals. Connect the ground wire to the ground stud located near the main switch making sure to allow enough lead length for door to open and close properly. After connecting all wires, replace the fuse covers back on to the fuses.

### Labor-Pilot Motor Connection

The cable exiting the controller box will be connected to the labor-pilot motor. The cable contains 6 wires. After determining the correct motor configuration, connect the wire labelled U1 to L1, V1 to L2, W1 to L3, and ground wire to motor ground. Wires labelled 5 and 6 are used to connect to the motor thermal overload sensor, if it has one. If the motor does not have an internal thermal sensing device, then connect wires 5 and 6 together.

Note: Once the Labor-Pilot and Controller are connected and verified, then test run the motor very briefly to verify the motor is rotating in the correct direction. If it is not rotating in the right direction, then change the direction of rotation by switching two phases of the incoming power at the fuseblock terminals or switching two phases at the motor terminals.



## 6.2.5 Wiring Diagram

## LABOR-PILOT CONTROLLER WIRING DIAGRAM

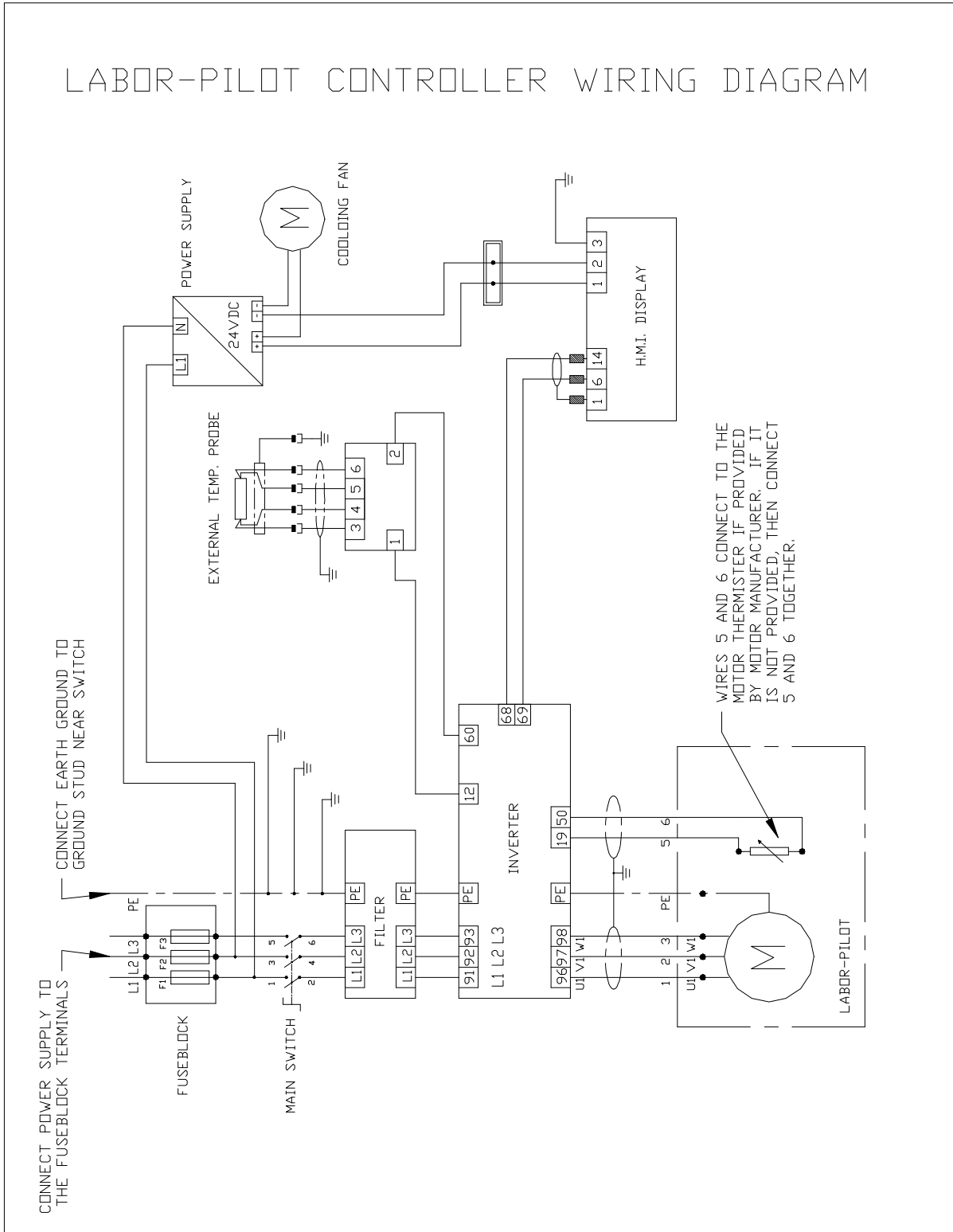

### 6.2.6 Functions:

The LABOR-PILOT Controller has the following functions:

- Clear text display with language selection
- Variable speed adjustment
- Displays for:
  - Set point value of speed
  - Actual value of speed
  - Actual value of motor current
  - Actual value of product temperature
  - Set point value of operating time in timer mode
  - Actual value of remaining time in timer mode
  - Actual value of operating hours
- Timer mode
- Error messages as text display

### 6.2.7 Operating elements:

The following operating elements are available and can be found on the front of the controller:

Operating element	Function
<ul style="list-style-type: none"><li>• Main switch</li></ul>	<ul style="list-style-type: none"><li>• Switching the power supply on and off</li><li>• Emergency stop</li></ul>
<ul style="list-style-type: none"><li>• Controls and displays (HMI)</li></ul>	<ul style="list-style-type: none"><li>• Switching the drive on and off</li><li>• Set point assignment</li><li>• Actual indication</li><li>• Malfunction indication</li></ul>

### 6.2.8 Operation of the controller:

On-off switching:

With the 1 button the drive is switched on, with the 0 button it is switched off again. The LED above the 1 button indicates the operation of the drive.

Speed regulation:

The ↑ and ↓ buttons are used for speed regulation. This depends on the selected display. Please find information on the matter in the descriptions of the displays.

Time function:

The Timer button is used to switch the Time function on and off. If the Timer function is switched on, the LED above the Timer button indicates this.

During the time function, the drive runs for the set period and is then switched off.

For starting, the 1 button must also be actuated and can be stopped again using the 0 button before the time has elapsed.

If the drive is stopped before the remaining time has elapsed, it will automatically be set to 0. When starting in timer mode, the remaining time is automatically set to the period for which the drive still has to run.







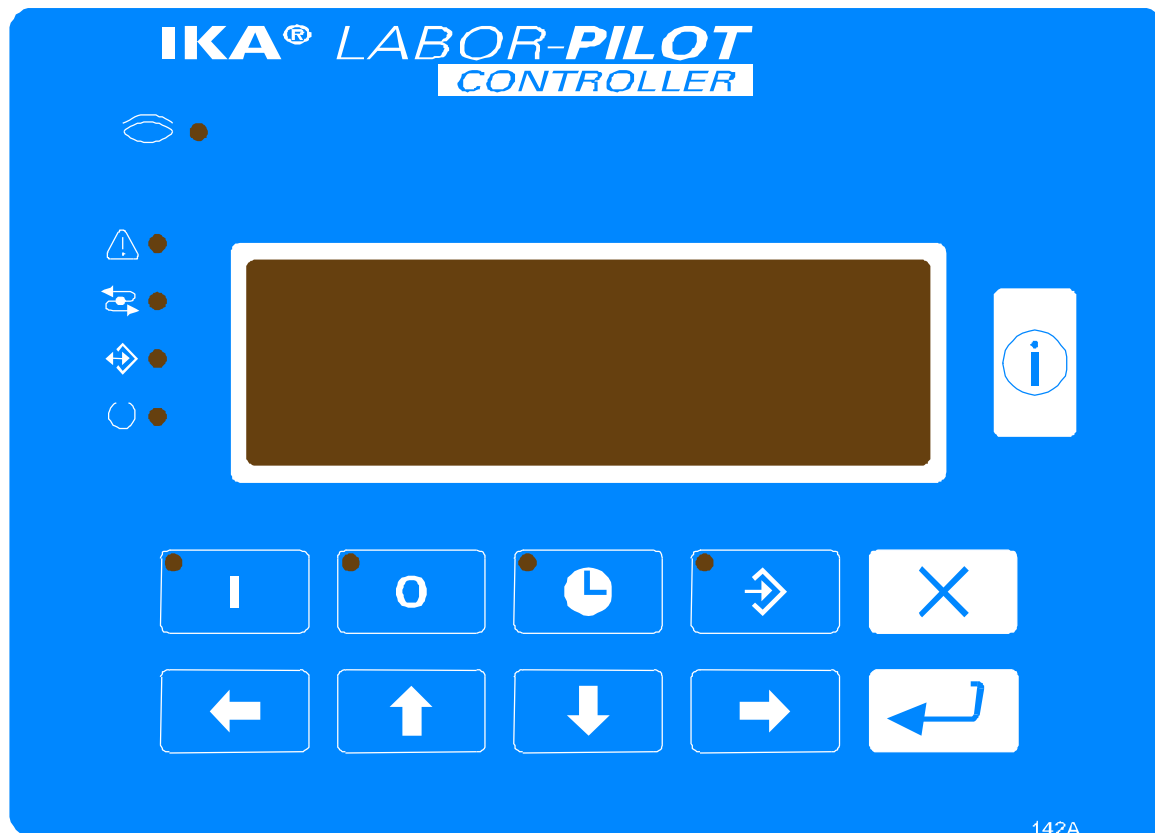

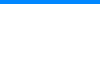

Automatic switching-off:

In case of each switching-on of the main switch or of failures of the FC or the motor, the drive will be automatically switched off and must be switched on manually again.





### 6.2.9 View of HMI display:

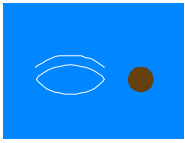

## 6.2.10 HMI function keys:

Keys	Page	Function	LED	
		all	Switching on the drive	Drive on
		all	Switching off the drive	no function
	TIMER	all	Switching on the time function: If the time function is switched on, the drive must be switched on first. It will then run for the indicated period and will then automatically switch off	Time function on/off
			no function	Time runs
		all	Deleting failures	-
		all	Paging to the previous display	-
		all	Paging to the following display	-
			Increasing the value (with auto-repeat function)	-
			Decreasing the value (with auto-repeat function)	-
		all	Only for setup function, password-protected	-
			Call and quit info display	-

## 6.2.11 LEDs of the HMI:

Name/symbol	Colour	State	Signification
	red	OFF	No hardware problem detected
		FLASHING	Battery low (this instrument has no battery)
		ON	HMI hardware error
	green	OFF	No button pressed
		ON	With each keystroke (visual feedback)
	red	OFF	No alarms
		FLASHING	Alarm requires acknowledgement (not used)
		ON	Alarm active
	red	OFF	no function
		FLASHING	no function
		ON	no function
	green	FLASHING	Communication error (with the frequency converter)
		ON	Communication OK (with the frequency converter)
	green	OFF	HMI hardware error
		ON	Device in operation

### 6.2.12 View of all display pages:

#### Display page 1:

s	p	e	e	d	X	X	X	X	X	1	/	m	i	n
t	e	m	p	.				X	X	°	C			

This is the start page after switching on; the speed can be adjusted here, too.

Display line	Display contents	Unit
1	Actual speed	[rpm]
2	Actual temperature	[°C]











Keys	Function	LED
	Switching on the drive	Drive on
	Switching off the drive	no function
TIMER	Switching the time function on/off	Time function on/off
	no function	Time runs (flashes)
	Deleting failures	-
	no function	-
	Paging to display 2	-
	Increasing the speed	-
	Decreasing the speed	-
	Setup function, password-protected	-
	Call and quit info display	-



**Display page 2:**

s e t	v a l .	X X X X X	1 / m i n
c u r r e n t		X . X X	A

Display line	Display contents	Unit
1	Set speed	[rpm]
2	Actual current consumption	[A]

Keys	Function	LED
	Switching on the drive	Drive on
	Switching off the drive	no function
 TIMER	Switching the time function on/off	Time function on/off
	no function	Time runs (flashes)
	Deleting failures	-
	Paging to display 1	-
	Paging to display 3	-
	Increasing the speed	-
	Decreasing the speed	-
	Setup function, password-protected	-
	Call and quit info display	-

**Display page 3:**

n o m . - t i m e	X X X	m i n
r e s t - t i m e	X X X	m i n

During timer operation, the set point value is set and the remaining time is displayed on this page.

Display line	Display contents	Unit
1	Setpoint time	[min]
2	Actual remaining time (after timer start)	[min]











Keys	Function	LED
	Switching on the drive	Drive on
	Switching off the drive	no function
	TIMER Switching the time function on/off	Time function on/off
	no function	Time runs (flashes)
	Deleting failures	-
	Paging to display 2	-
	Paging to display 4	-
	Increasing the time	-
	Decreasing the time	-
	Setup function, password-protected	-
	Call and quit info display	-

**Display page 4:**

i	n	v	e	r	t	e	r		X	X	X	X	X	.	X		h
m	o	t	o	r					X	X	X	X	X	.	X		h

On this page, the operating hours of the frequency converter and the motor are displayed.









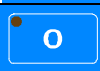

Display line	Display contents	Unit
1	Actual value of operating hours of converter	[h]
2	Actual value of operating hours of motor	[h]

Keys	Function	LED
	1 Switching on the drive	Drive on
	0 Switching off the drive	no function
	TIMER Switching the time function on/off	Time function on/off
	no function	Time runs (flashes)
	Deleting failures	-
	Paging to display 3	-
	Paging to display 5	-
	Increasing the speed	-
	Decreasing the speed	-
	Setup function, password-protected	-
	Call and quit info display	-

**Display page 5:**

A d j u s t m e n t   c o n t r a s t  
d i s p l a y :

The readability of the display strongly depends on the angle of view to the display. This can be balanced by adjusting the contrast of the display on this page.

Keys		Function	LED
	1	Switching on the drive	Drive on
	0	Switching off the drive	no function
	TIMER	Switching the time function on/off	Time function on/off
		no function	Time runs (flashes)
		Deleting failures	-
		Paging to display 3	-
		Paging to display 5	-
		Increasing the contrast	-
		Decreasing the contrast	-
		Setup function, password-protected	-
		Call and quit info display	-











**Display page 6:**

S e l e c t l a n g u a g e :		
1	=	e n g l i s h

On this page, the operator language is selected.  
At present, the following languages can be selected:

No.	Display	Language
1	English	English
2	Deutsch	German
3	Francais	French

Display line	Display contents	Language
2	Selected language	

Keys	Function	LED
	Switching on the drive	Drive on
	Switching off the drive	no function
 TIMER	Switching the time function on/off	Time function on/off
	no function	Time runs (flashes)
	Deleting failures	-
	Paging to display 3	-
	Paging to display 5	-
	Select next language	-
	Select previous language	-
	Setup function, password-protected	-
	Call and quit info display	-

## 7 Commissioning of the LABOR-PILOT 2000/4

For the following description refer to the figure

### 7.1 Start-up

After proper installation of the machine on a safe ground and proper installation of the controller, the device is ready for start-up. Please read the following sections to understand how your specific machine will work. It is important that user fully understands how the machine will work for safe operation.

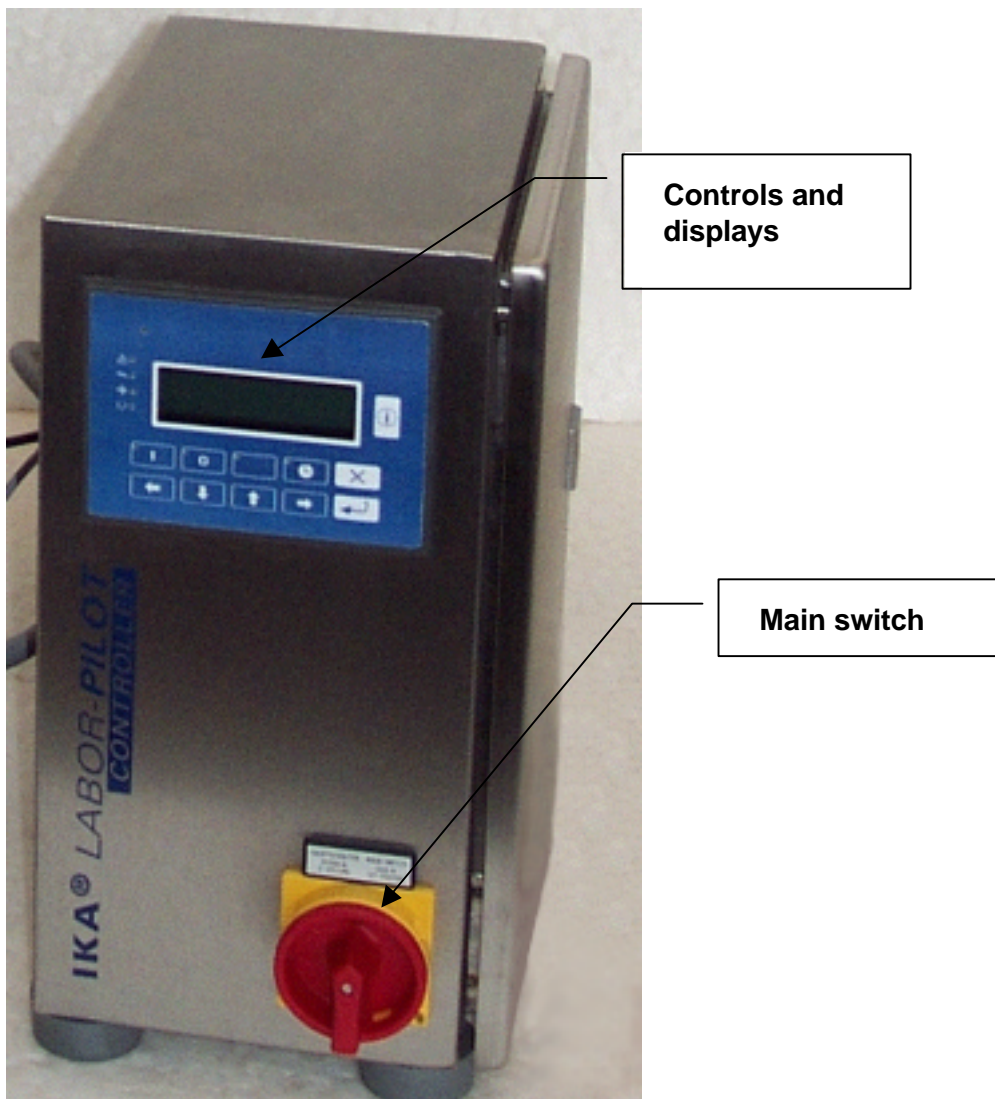

## 7.2 Brief test

The following should be checked during a brief test run:

- Direction of rotation of the motor
- Unusual, mechanical noise



**Attention**

**The device may only run dry for a short period, otherwise the rotary shaft seal on the product side will be destroyed.**



**Attention**

**In case of the colloid mill module, observe a sufficient running clearance between the grinding gears. Otherwise the machine may be damaged.**



**Attention**

**Check by briefly switching-on if the motor turns in the marked direction (arrow on the blower housing). If the motor turns in the wrong direction, the input rotating field in the connecting plug must be changed by an authorised person by means of shifting two phases.**



**Danger**

**Never reach into the mixing chamber while the motor is running. The rotating mixing tools present the risk of injury.**

## 7.3 Information on working with product

The LABOR-PILOT has been particularly designed for processing liquids. With the MHD module, the LABOR-PILOT can also mix powdery solids with liquids and homogenise them. However, for successful operation with the machine, the following must be observed:

### 7.3.1 Peripheral equipment

#### 7.3.1.1 General

The LABOR-PILOT is not self-priming, however, it can build up a pressure at the outlet and thus overcome a certain lift. The lift depends on the tool used and the speed. In case of the MK module, the lift also depends on the set grinding gap.

A precondition for a proper function and a constant mixing performance is that the product to be mixed is supplied uniformly e.g. via the optional feeding hopper (does not apply to the MHD module). Viscous product to be mixed, which does not flow independently into the machine via a hopper, may require to be fed into the LABOR-PILOT using a pump. To feed the liquid component or to circulate the product to be mixed, pumps working according to the displacement principle, such as rotary piston, gear or eccentric screw pumps, proved successful.

They have a relatively stable characteristic and are generally driven by variable speed geared motors.

When using a pump, pay attention that the permissible operating pressure of 3 bar is not exceeded.

#### 7.3.1.2 MHD module

In case of the MHD module, both the solid and the liquid component must be **proportioned** into the device at the respective inlet socket. In the device itself, the components are mixed or homogenised and discharged from the device via an outlet socket.

The controlled feeding of the liquid and the solid component results in a final product with proportional quantities, the exactness depending on the feeding devices. Feeding can be realised using e.g. the following devices:

	Proportioning device	Remark
<b>Proportioning of the solid component</b>	Volumetric proportioning screw	Reduced expenditure, varying proportioning accuracy
	Gravimetric ratio weigher	High expenditure, high proportioning accuracy
<b>Proportioning of the liquid component</b>	Eccentric screw pump	Simple, not suitable for all products
	Rotary-piston pump, gear pump	High expenditure, suitable for most products

The MHD module can build up a pressure on the outlet side and thus overcome a certain lift. The lift depends on the tool used and the speed.



## 7.3.2 Adaptation possibilities of the LABOR-PILOT to the process

### 7.3.2.1 General

The LABOR-PILOT can be adapted to the application in question by means of individually exchangeable mixing tools.

However, attention has to be paid that generally the possible throughput rates and lifts decrease with the use of finer tools.



**Note**

**The generator 6F is not suitable for operation with the MHD module and must not be installed there.**

**With the MHD module, the standard generator to be used is the 2P generator (pump rotor combined with a single-rim stator). Alternatively, the generators 2G and 4M can be used.**

### 7.3.2.2 Grinding gap adjustment MK module

The colloid mill MK module can be adapted to the process using the continuous grinding gap adjustment. The grinding gap is adjusted manually by turning the adjusting ring being located on the outside of the housing. In dependence on the angle of rotation the following grinding gap is obtained.

**Table: Radial gap adjustment**

Indicated angle in °	Rotations of the adjusting ring	Radial gap in mm
0	0	0
90	1/4	0,104
180	1/2	0,208
270	3/4	0,312
360	1	0,416
450	1 1/4	0,520
540	1 1/2	0,624
630	1 3/4	0,728
720	2	0,832
810	2 1/4	0,936
900	2 1/2	1,040
990	2 3/4	1,144
1080	3	1,247
1170	3 1/4	1,351
1260	3 1/2	1,455
1350	3 3/4	1,559
1440	4	1,663
1530	4 1/4	1,767
1620	4 1/2	1,871
1710	4 3/4	1,975
1800	5	2,079

### Adjusting the grinding gap

#### *Zero position*

During initial start-up, after a disassembly as well as after a longer operating period, the grinding gap adjustment must be checked and, if necessary, be corrected. For that purpose, first loosen the lock nuts (736) at the star knob screws (734) of the adjusting ring (716). Subsequently, turn the adjusting ring clockwise until it reaches a tangible stop. The radial gap is now set to zero, i.e. the rotor is now in contact with the stator. In this position, the machine must definitely not be switched on. Now, the running clearance must be adjusted.

#### *Running clearance*

The adjusting ring (716) is now turned anticlockwise until the desired clearance according to the radial gap adjustment table is reached. For this, the adjusting ring must be turned (clockwise to the left)

by at least 180° in order to ensure a sufficiently safe running clearance between rotor and stator. Subsequently, check by manually turning the shaft if the rotor can be rotated freely. This can be done with the help of the delivered open-end wrench (OW10) which is placed on the upper shaft nut and is used to turn the shaft clockwise. Subsequently, the lock nuts (736) at the star knob screws (734) of the adjusting ring (716) must be tightened.

### 7.3.3 Starting the machine

Fundamentally, it must be mentioned that the LABOR-PILOT is a flow machine. As a result of the high speed, a minimum liquid content of the product to be mixed is required for the function of the machine. The possible mixing ratio is strongly dependent on the product as with a too high solids content the limit of the permissible product viscosities may be reached.



**Note**

**The machine is not appropriate for the exclusive supply and treatment of pure dry substances. This may cause serious damages of the device.**



**Note**

**The machine is not suitable for processing abrasive substances. Abrasive substances cause early wear particularly of the rotary shaft seal which may lead to undesired product leakage.**

Therefore it is recommended to provide a flow monitor when using the machine in unsupervised systems which monitors the liquid supply and immediately switches the LABOR-PILOT off if no liquid is supplied.

Moreover, this basic rule influences the sequence of starting and stopping the machine. The sequence should be as follows:



**Attention**

**The instrument may only be switched on after radial gap adjustment.**

### Starting the machine

1. Preselect the maximum standard speed of 7900 rpm (only for operation at the LABOR-PILOT CONTROLLER)
2. Start the LABOR-PILOT motor
3. Start the liquid component (pump)

4. Start the powdery component (only with MHD module)
5. If necessary, increase speed slowly

### Stopping the machine

1. Stop the powder supply (only with MHD module)
2. Stop the liquid supply, if necessary rinse briefly first
3. Stop the LABOR-PILOT motor



**Attention**

The device may only run dry for a few seconds, otherwise the rotary shaft seal on the product side will be destroyed.



**Attention**

The instrument may only be operated for a short moment with closed valve on the discharge side. During longer operation, the frictional heat of the rotary shaft seal is no longer dissipated, which means that it heats inadmissibly and may be destroyed.



**Attention**

After having used the machine it must be cleaned. This is particularly important in case of hardening product to be mixed, as the function of the rotary shaft seal on the product side may be affected or it may be destroyed.



**Note**

For operation at the LABOR-PILOT CONTROLLER, the machine should be started at a maximum speed of 7900 rpm. If necessary, decrease the speed slowly.

### 7.3.4 Calculation of the throughput rate

In dependence on the tool, the application of the LABOR-PILOT is possible in a wide range of throughputs. The actually possible maximum throughput and thus the calculation of the supplied product flow depends on the following factors:

- Viscosity of the product to be mixed
- Swelling properties of the product to be mixed
- Solids concentration of the product to be mixed
- Lift at the outlet
- Dispersing, grinding or mixing tool
- Grinding gap (Colloid mill MK module)

Fundamentally, it applies that per unit of time only as much liquid and solids can be supplied that can be mixed and discharged by the LABOR-PILOT.

Moreover, it must be stated that generally the mixing result will be best if achieved close to the maximum possible throughput. In case of low throughputs, the result and a uniform liquid flow can also be improved by means of an “artificial load”, e.g. a throttle at the product discharge.

If no practical values are available, a test must be carried out to settle the question which product-specific maximum throughput can be realised.

If the LABOR-PILOT is operated at the LABOR-PILOT CONTROLLER, the standard speed of 7900 rpm must be adjusted as output speed. This applies to the basic device as well as to all other modules. All further optimisations should be started from this speed. Fundamentally, the speed adjustment should not be higher than required by the process. An increased speed causes stronger wear particularly of the rotary shaft seal on the product side.

### 7.3.5 Operation using circulation processes with the hopper

If the basic device, the module DISPAX-REACTOR<sup>®</sup> DR or the colloid mill module are operated with the optional hopper, the circulation pipe, the RW 28 basic stirrer or the wiping stirrer, the following must be observed:



**Danger**

Particularly when using the wiping stirrer the lowest speed of the stirring motor must be adjusted during start-up and before switching on. A too high speed adjustment presents the danger that product to be mixed may spurt out of the hopper.



**Danger**

In case of prolonged circulation of the product to be mixed using the LABOR-PILOT, the product to be mixed may strongly heat particularly at high speeds and with a high power consumption. Observe the temperature development in the container and at the circulation pipe and, if necessary, connect a cooling unit. In case of temperatures above 65 °C at the outer casing, provide a suitable touch guard, otherwise there is the danger of burns.



**Danger**

When working with the LABOR-PILOT at the open hopper, wear corresponding protective clothing as product may squirt out of the hopper both with the stirring motor switched on and switched off.



**Danger**

Never reach into the container or the stirring shaft incl. stirrer while the stirring motor is running.



**Never reach into the open hopper when working with the LABOR-PILOT.**

**Procedure**

- The straight-way ball valve on the inlet side of the LABOR-PILOT serves as a barrier between the hopper contents and the LABOR-PILOT. While the LABOR-PILOT is running, the straight-way ball valve must be opened to prevent dry running.
- The 3-way tap cock on the outlet side should only be operated in the following two switching positions, if possible:
  - Outlet open, connection to the outlet socket (see figure 1), product will be discharged while the machine is running. Collect the discharged product in a suitable receiver or use a suitable discharge pipe.
  - Outlet open, connection to the circulating elbow (see figure 2), product will be circulated in the hopper while the machine is running.

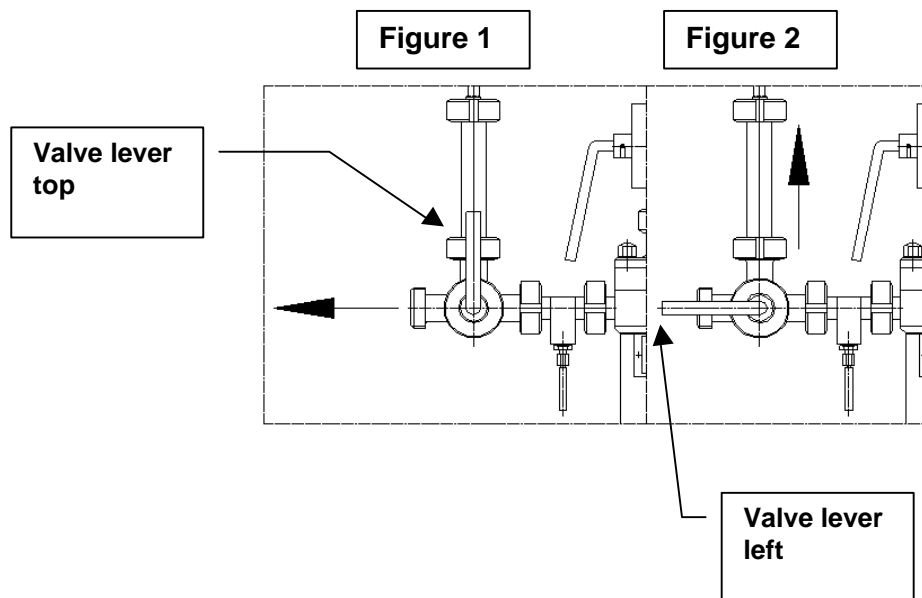

- With closed outlet, the LABOR-PILOT may only be operated for a short moment, as the product in the outlet chamber may very strongly heat.



**When opening the 3-way tap cock towards the outlet socket while the machine is running pay attention to the delivery pressure which might cause the product to come out very fast when opening the cock. With open outlet wear corresponding protective clothing.**



## 8 Assembly and disassembly

In the following chapter the most important assembly work is described.



**Note**



**Danger**

**After the assembly work is completed and before the drive is switched on, check the clearance of the machine's drive shaft by manually turning it. In doing so, protect the drive against inadvertent starting!**

**Before any maintenance and repair work switch off the main switch of the power supply and lock it with a padlock! The key of this lock must be with the person carrying out the maintenance or repair work!**



## 8.1 Fitting tools

For assembly and disassembly it is advisable to use the delivered tool set:

Item	Quan-	Unit	Order no.	Designation
10	1	pc.	1056917	Tool bag
20	1	pc.	1056918	Open-end wrench OW 6/7
30	2	pc.	1056919	Open-end wrench OW 10/13
40	1	pc.	1056921	Hexagon socket screw key OW 5
50	1	pc.	1056922	Pin d=6 mm
60	1	pc.	1056923	Slotted screw driver size 4.5 mm
70	1	pc.	1056924	Articulated hook wrench size 35-60
80	1	pc.	1056361	Mounting sleeve for rotary shaft seal
90	1	pc.	1057205	Circlip pliers size S1



## 8.2 Disassembly of generator and rotary shaft seal

- With an easy later disassembly in mind we recommend to slightly coat the hubs of rotors, distance sleeves, and O-rings with a suitable grease before assembly.
- During assembly pay attention that the O-rings between the individual parts must lie correctly in the groove when fitting parts together.

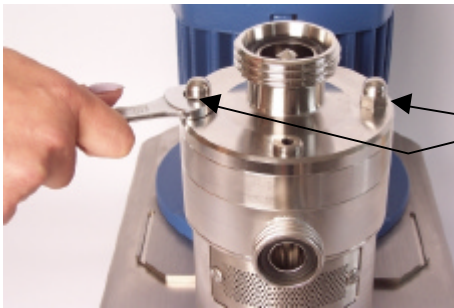

720



434

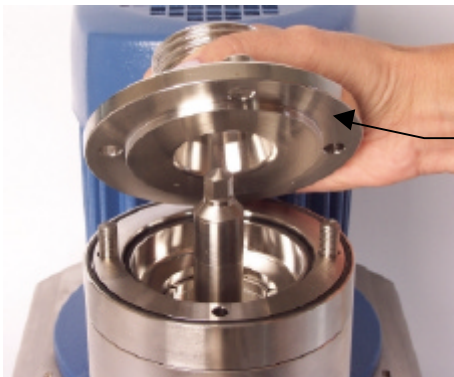

704

- Detach the product pipes
- Unscrew and remove 2 cap nuts (720)

- Remove inlet socket (704) upwards. Remove O-rings (608, 610).



904

- Remove stator (904) upwards

- Unscrew hexagon socket screw plug (434) anticlockwise using hexagon socket screw key OW 5 and remove it

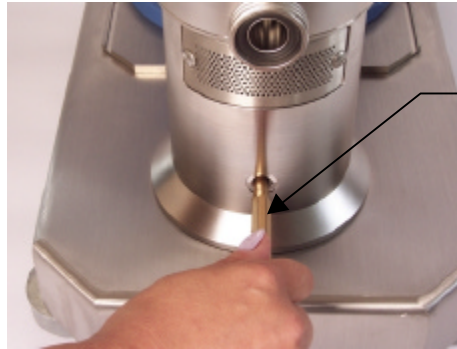

Locking pin



732



730

- Put locking pin  $\varnothing 6$  through the bore of the lantern and into the bore of the shaft (426)



730

Unscrew pressing nut (730) anticlockwise using the open-end wrench OW10

- Remove pressing nut (730)

- Pull off 2 distance sleeves (732) upwards, see next two figures



732



904



905

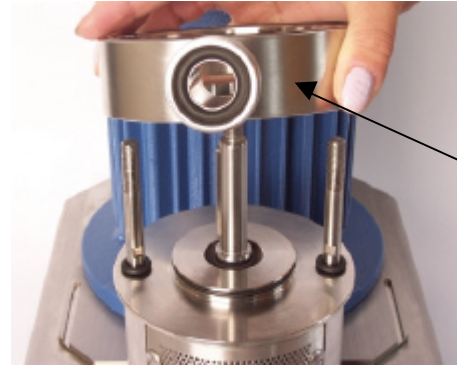

710

- Pull off rotor (904)
- Pull off distance washer (905) upwards
- Remove pump housing (710) upwards. Remove O-rings (608, 610).



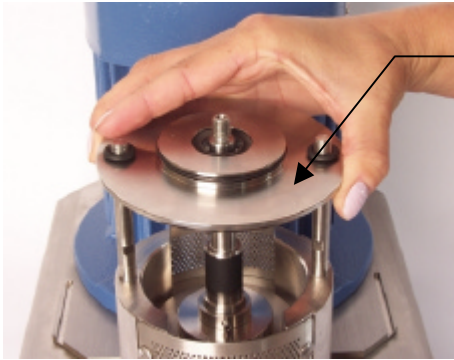

500

- Take off both O-rings (614)
- Remove flange gasket (500) upwards

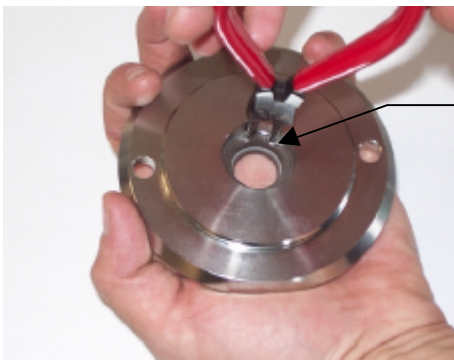

502

- Remove circlip (502) and force rotary shaft seal (501) out of the flange gasket using the thumb or a bolt



501

### 8.3 Assembly of rotary shaft seal

- Assembly is carried out in reverse order as described in 9.3 Disassembly of rotary shaft seal.
- With an easy later disassembly in mind we recommend to slightly coat the hubs of rotors and distance sleeves with a suitable grease before assembly.
- Keep the sealing surfaces free from dust and impurities. Pay attention to the correct installation position of the parts. In particular
- Press the new rotary shaft seal (501) into the flange gasket (500) using the rotary shaft seal mounting sleeve.
- Do not forget the two O-rings (614) at the stud bolts as well as the total of four O-rings between the housing parts (608, 610). The O-rings at the stud bolts (614) as well as the two exterior O-rings (608) between the housing parts exclusively seal the heating jacket. If the heating jacket is not used, these O-rings need not be mounted.
- see also 8.4 Disassembly and assembly of O-ring seals

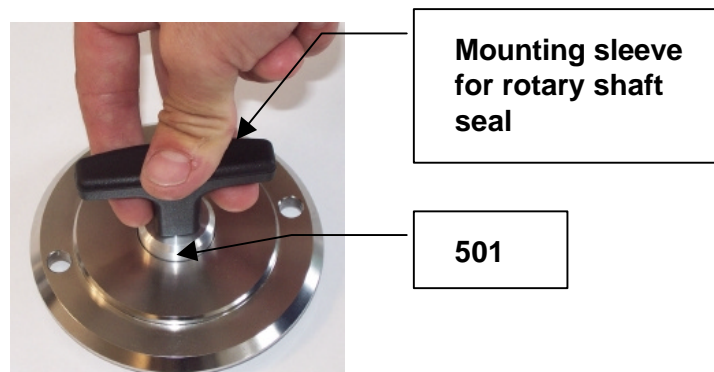

- During assembly pay attention that the O-rings between the individual parts must lie correctly in the groove when fitting parts together. The O-rings must not be twisted or dented by components.



**Note**

**The rotary shaft seal must fit uniformly and under no circumstances at an angle into the flange gasket. Otherwise the tightness of the ring is not ensured.**



**Note**

**Pay attention to the correct installation position of the ring. The sealing lip must be installed so that it points towards the product side. Only this way can it seal the machine against pressure**



Note

The rotary shaft seal must not be damaged during assembly. Even smaller defects of the sealing lip result in leakage.



Note

The pressing screw (730) should be screwed hand-tight and then be tightened with a tightening torque of approx. 17 Nm. It is recommended to additionally lock the thread with a liquid but with normal tools detachable screw locking (e.g. LOCTITE).



## 9 Modification of the basic device to other modules

### 9.1 General notes



**Danger**

**Before any modification switch off the main switch of the power supply and lock it with a padlock! The key of this lock must be with the person carrying out the maintenance or repair work!**

The user has to ensure that the modification and assembly work may only be carried out by authorised and qualified experts who have thoroughly read the operating instructions and are sufficiently informed.

### 9.2 Preparatory work:

- Disconnect the current supply
- Dismount accessories, such as shut-off valves, hoppers etc.
- Detach piping from the inlet and outlet side
- Motor and lantern remain on the base plate

### 9.3 Modification to DR module

#### 9.3.1 Disassembly of pump unit

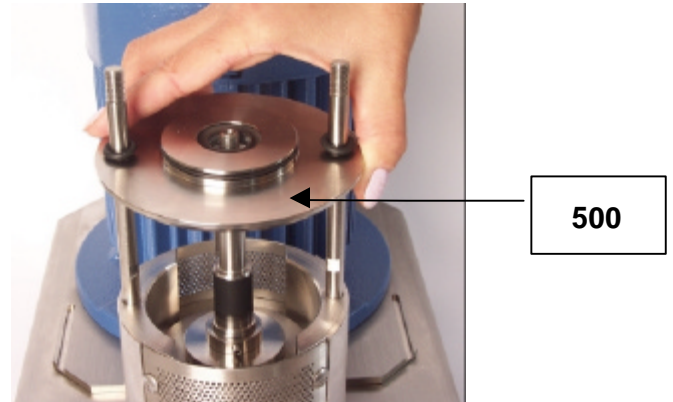
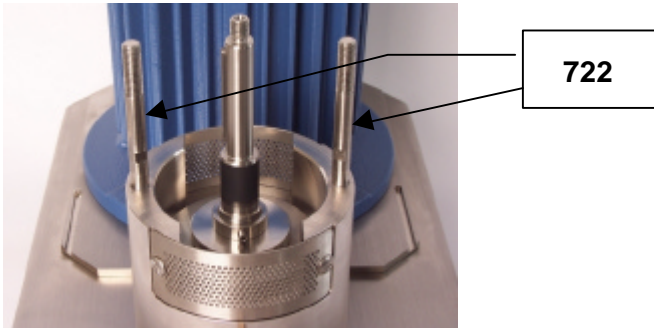

#### 9.3.2 Assembly of DR module

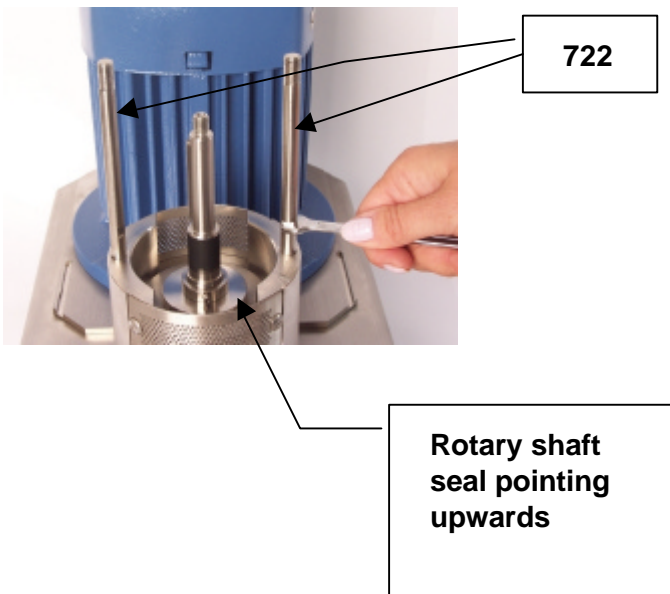

- Disassembly is carried out in the order as described in 8.2 Disassembly of rotary shaft seal.
- Unscrew and remove 2 stud bolts (722, short)
- Screw in 2 stud bolts (722, long)

- Put on flange gasket (500)

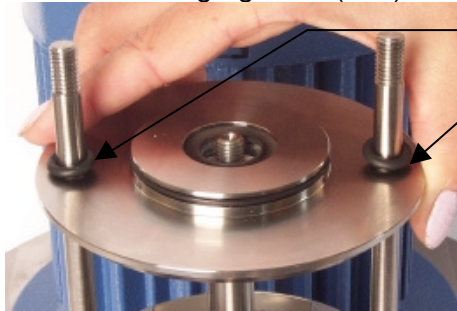

614

- Put on 2 O-rings (614) (sealing of heating jacket)

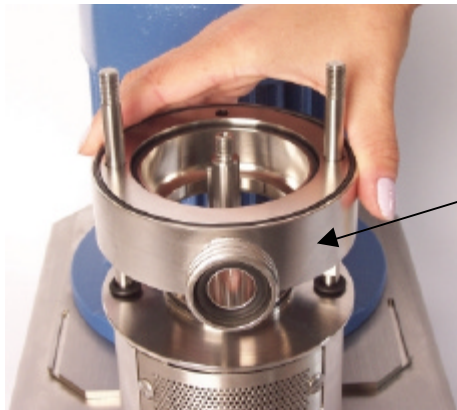

710

- Put on pump housing (710)
- Insert two O-rings (608, 610) into the chamber, on the outside to seal the double casing (can be dropped if the double casing is not used), on the inside to seal the mixing chamber

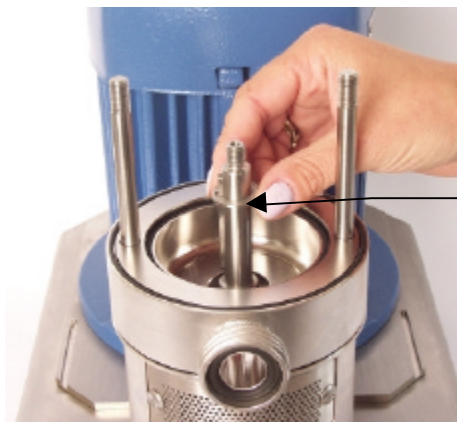

905

- Put on distance washer (905)



1004

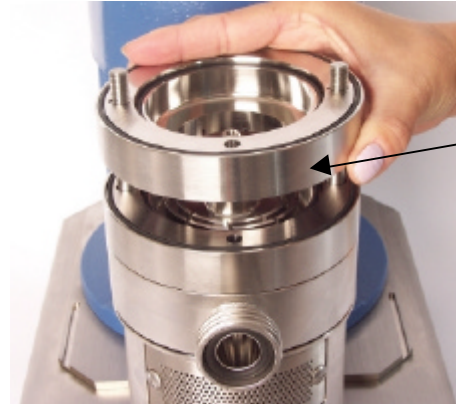

904



1004



904

- Put on rotor 6F (1004)
- Put on stator 6F (1004)
- Insert two O-rings (608, 610) into the stator, on the outside to seal the double casing (can be dropped if the double casing is not used), on the inside to seal the mixing chamber
- Put on rotor 4M (904)
- Put on stator 4M (904)
- Insert two O-rings (608, 610) into the stator, on the outside to seal the double casing (can be dropped if the double casing is not used), on the inside to seal the mixing chamber

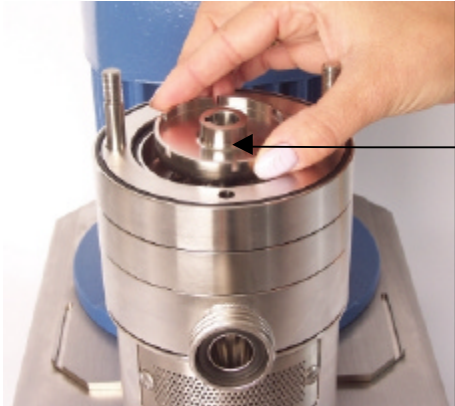

804

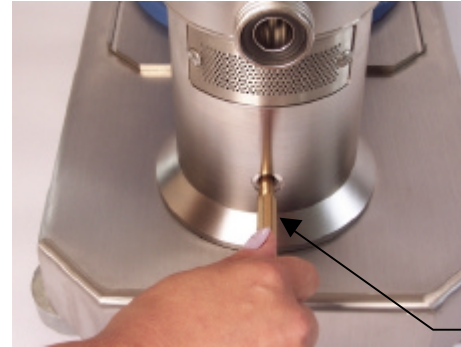

Locking pin

- Put on rotor 2G (804)



804

- Put on stator 2G (804)
- Insert two O-rings (608, 610) into the stator, on the outside to seal the double casing (can be dropped if the double casing is not used), on the inside to seal the mixing chamber
- Tighten pressing screw (730) manually



730

- Put locking pin  $\varnothing 6$  through the bore of the lantern and into the bore of the shaft (426)

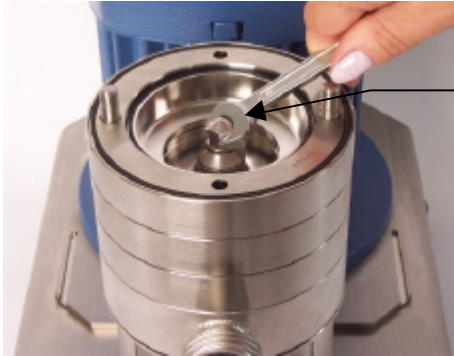

730



434

- Tighten the pressing screw (730) clockwise using the open-end wrench OW10



**Note**

The pressing screw (730) should be screwed hand-tight and then be tightened with a tightening torque of approx. 17 Nm. It is recommended to additionally lock the thread with a liquid but with normal tools detachable screw locking (e.g. LOCTITE).

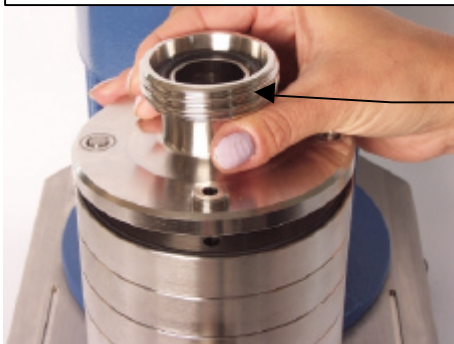

704

- Put on inlet socket (704)
- Insert one O-ring (624) each into the cap nut, if necessary grease it slightly so that it sticks to the groove. The O-rings can be dropped if the double casing is not used.



720

- Tighten 2 cap nuts (720)

- Tighten hexagon socket screw plug (434) clockwise using a hexagon socket screw key OW 5

## 9.4 Modification to MHD module

### 9.4.1 Disassembly of pump unit

- Disassembly is carried out in the order as described in 8.2 Disassembly of rotary shaft seal.

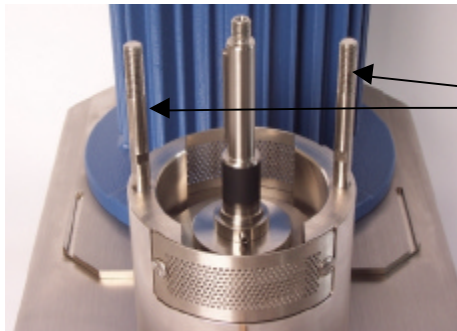

- Unscrew and remove 2 stud bolts (722, short)

### 9.4.2 Assembly of MHD module

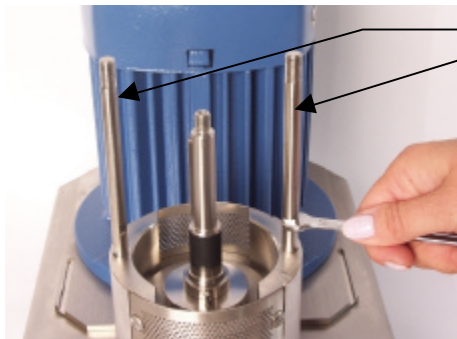

- Screw in 2 stud bolts (722, long)

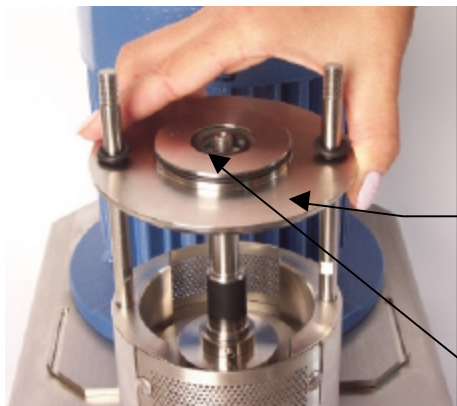

- Put on flange gasket (500)

Rotary shaft  
seal pointing  
upwards

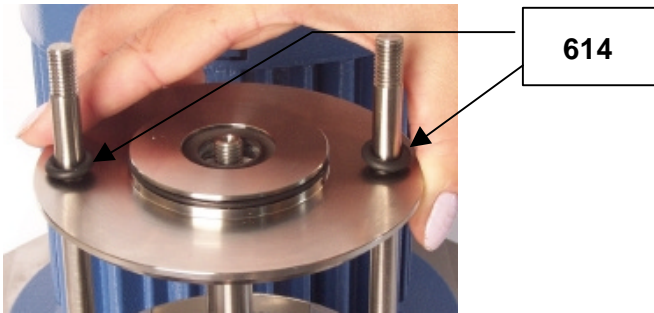

- Put on 2 O-rings (614)

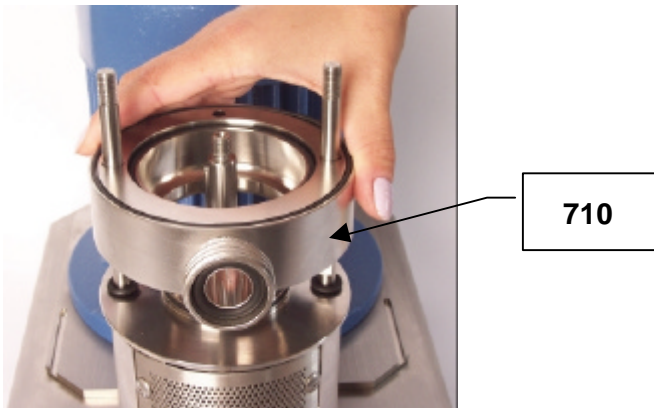

- Put on pump housing (710)
- Insert two O-rings (608, 610) into the chamber, on the outside to seal the double casing (can be dropped if the double casing is not used), on the inside to seal the mixing chamber

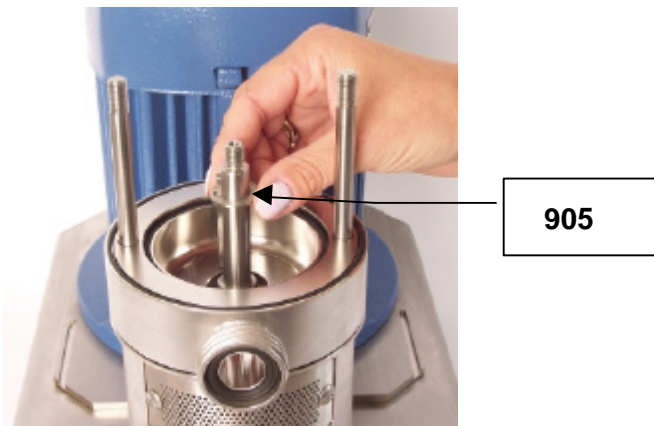

- Put on distance washer (905)

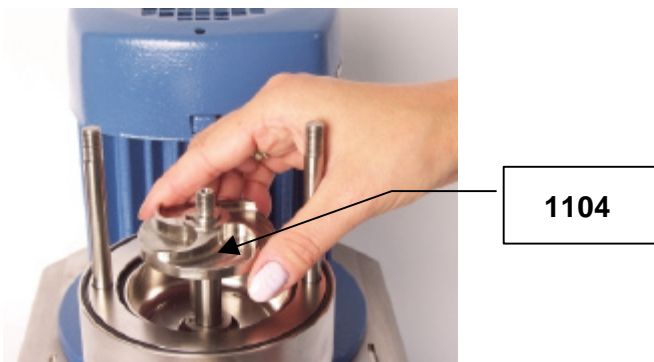

- Put on pump wheel 2P (1104)





**806  
centre  
position**

**804  
lower  
position**



**804  
upper  
position**



**802**



**Locking  
pin**

- Put on 2 mixing tools (804) at the top and at the bottom and 1 mixing tool (806) in the centre position. The three mixing tools must be put on so that adjacent stirrer blades are staggered. For this the position of the keyway is designed differently

- Screw on feeding screw (802)

- Put locking pin  $\varnothing 6$  through the bore of the lantern and into the bore of the shaft (426)



802

- Tighten the feeding screw (802) clockwise using the open-end wrench OW10



**Note**

The feeding screw (802) should be screwed hand-tight and then be tightened with a tightening torque of approx. 17 Nm. It is recommended to additionally lock the thread with a liquid but normal tools detachable screw locking (e.g. LOCTITE).



1104

- Put on stator 2G (1104)
- Insert two O-rings (608, 610) into the stator, on the outside to seal the double casing (can be dropped if the double casing is not used), on the inside to seal the mixing chamber



708

- Put on pump housing (708)
- Insert two O-rings (608, 610) into the chamber, on the outside to seal the double casing (can be dropped if the double casing is not used), on the inside to seal the mixing chamber

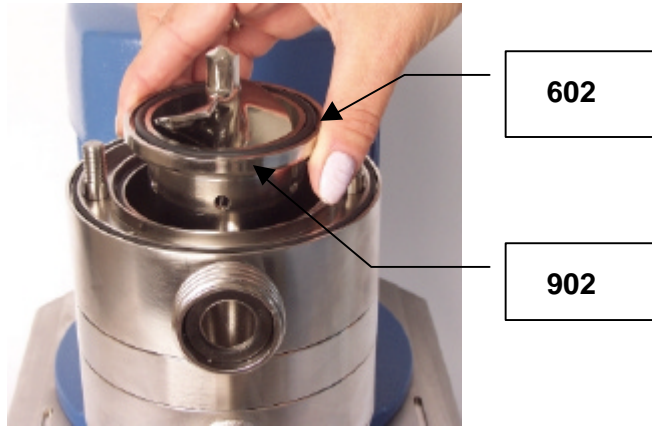

602

902



434

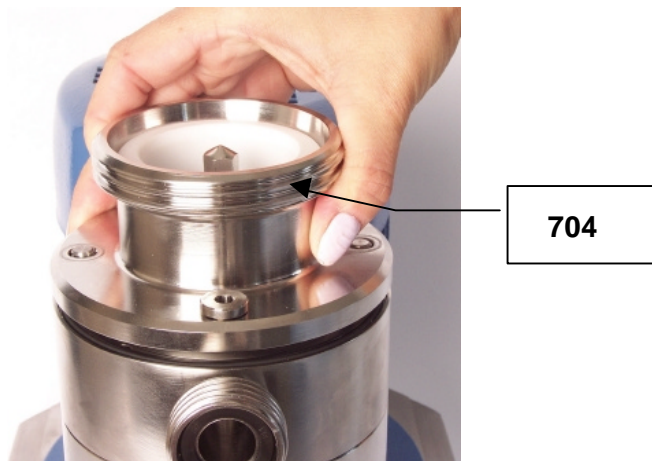

704



720

- Place injector casing (902)
- Insert O-ring (602) into the injector casing from above
- Put on inlet socket (704)
- Insert one O-ring (624) each into the cap nut, if necessary grease it slightly so that it sticks to the groove. The O-rings can be dropped if the double casing is not used.
- Tighten 2 cap nuts (720)
- Tighten hexagon socket screw plug (434) clockwise using a hexagon socket screw key OW 5

## 9.5 Modification to MK module

### 9.5.1 Disassembly of pump unit

- Disassembly is carried out in the order as described in 8.2 Disassembly of rotary shaft seal.

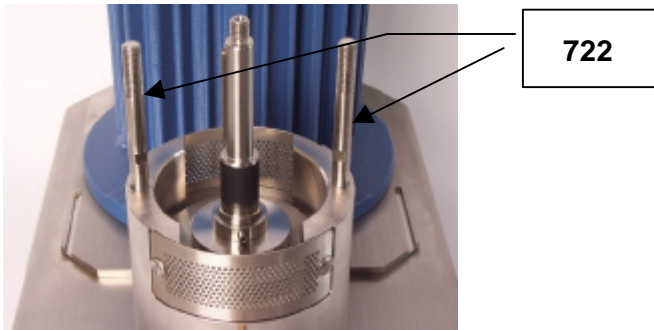

- Unscrew and remove 2 stud bolts (722, short)

### 9.5.2 Assembly of MK module

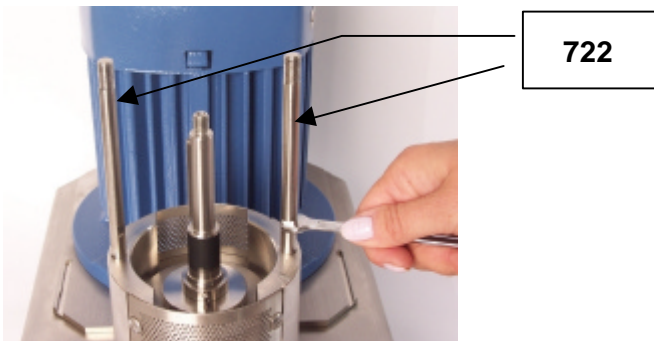

- Screw in 2 stud bolts (722, long)

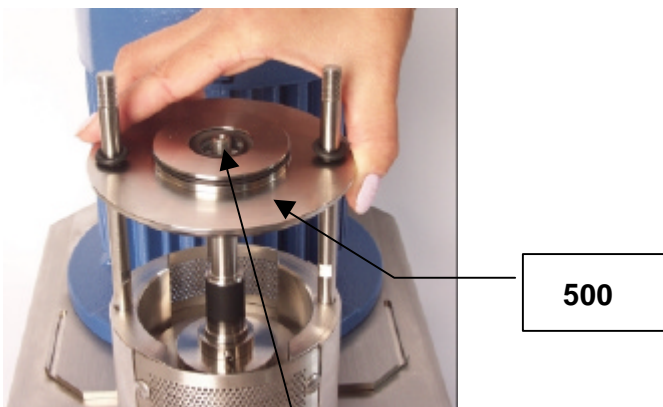

- Put on flange gasket (500)

Rotary shaft  
seal pointing  
upwards

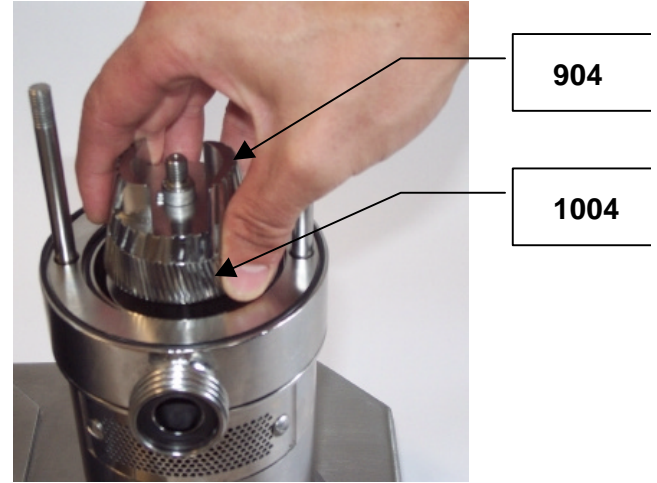
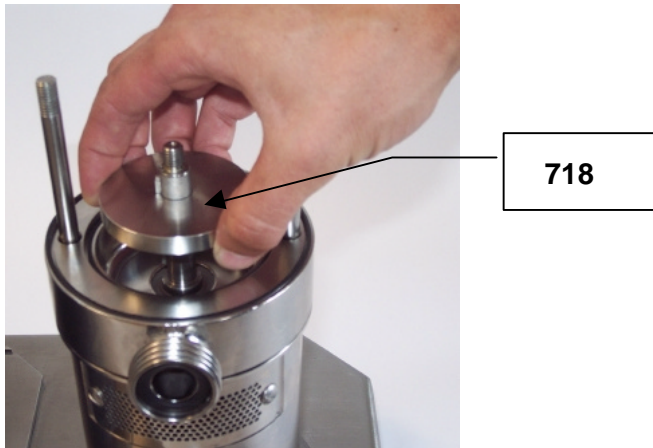
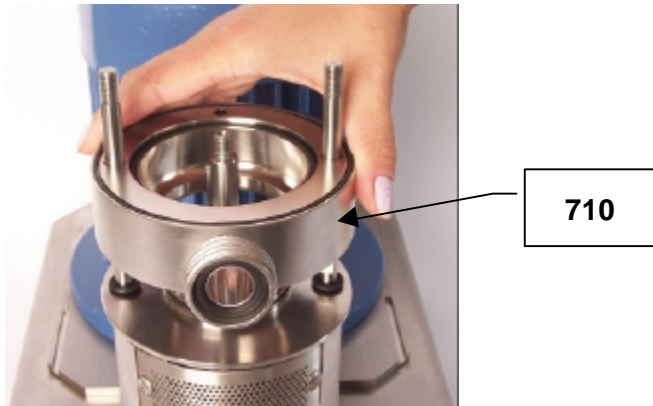
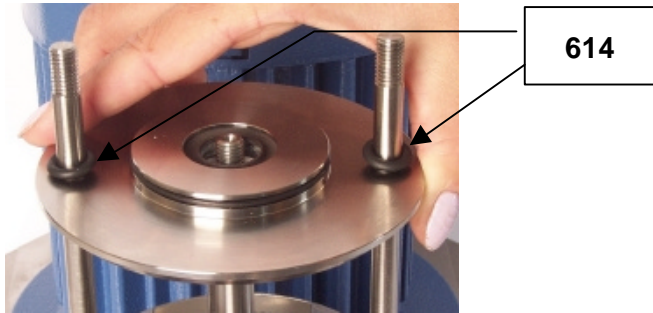

- Put on 2 O-rings (614)
- Put on pump housing (710)
- Insert two O-rings (608, 610) into the chamber, on the outside to seal the double casing (can be dropped if the double casing is not used), on the inside to seal the mixing chamber

- Put on pressure plate (718)

Screw (740) rotor part 1 together with part 2 (904, 1004) and push it on the shaft.



732

- Put on 1 distance sleeve (732)



730

- Screw on pressing screw (730)

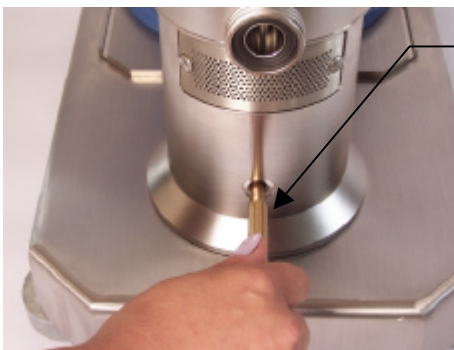

Locking  
pin

- Put locking pin  $\varnothing 6$  through the bore of the lantern and into the bore of the shaft (426) and tighten the pressing screw (730) clockwise using the open-end wrench OW10



Note

The pressing screw (730) should be screwed hand-tight and then be tightened with a tightening torque of approx. 17 Nm. It is recommended to additionally lock the thread with a liquid but with normal tools detachable screw locking (e.g. LOCTITE).



**728,  
602**

- Put on housing (728) with O-ring (602)

Premount stator with adjusting ring

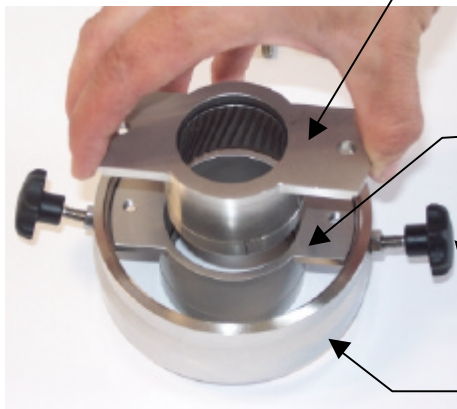

**906,  
604**

**1006,  
603**

**734,  
736**

**716**

- Insert O-ring (603) in stator part 2 (1006)
- Screw both star knob screws (734) with locking nut (736) onto adjusting ring (716). Screw on star knob screws only until the thread takes hold. Do not tighten the locking nuts.
- Insert adjusting ring (716) with its nose into the keyway of the stator part 2 (1006)
- Fix stator part 1 (906) with stator part 2 (1006) using the two hexagon head screws (712). Pay attention that the adjusting ring can be freely rotated in the keyway between the two stators.

Place premounted stator unit



**630**

**614**

**728**

- Push the premounted unit into housing (728) from above
- Insert O-ring (604) into stator part 1 (906) (product sealing)
- Put on both O-rings (614) (sealing of heating jacket)
- Insert O-ring (630) into housing (728) (sealing of heating jacket)



704

- Put on inlet flange (704)
- Insert one O-ring (624) each into the two cap nuts, if necessary grease it slightly so that it sticks to the groove. The O-rings can be dropped if the double casing is not used.

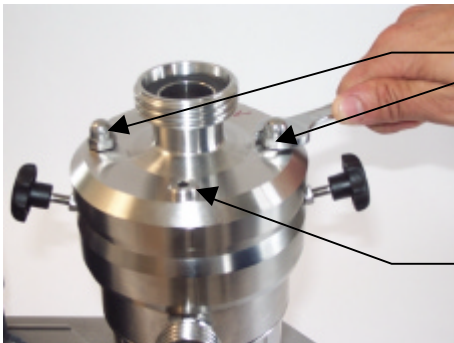

720

434

- Tighten both cap nuts (720)



434

- Tighten hexagon socket screw plug (434) clockwise using a hexagon socket screw key OW 5



Attention

**Before commissioning the device with colloid mill MK module, the running clearance between rotor and stator must be adjusted (see also 7.3.2.2). Otherwise the device might be damaged.**



## 10 Maintenance

### 10.1 The rotary shaft seal



#### Attention

The device may only run dry for a short period, otherwise the rotary shaft seal on the product side will be destroyed.

The rotary shaft seal made of a special PTFE compound can yield an excellent service life if:

- permissible pressure ratios prevail
- no abrasive product is used
- sufficient moistening and cooling by a continuous product flow is given

The rotary shaft seal itself is subject to a certain degree of wear. The wear is dependent on:

- the pressure difference
- the temperature
- the abrasiveness of the dispersing material
- the speed

Any damage to the seal can be detected by the following:

- Dispersing material escapes at the side through the two windows of the bearing lantern
- Pressure drop in the product chamber with closed system



#### Note

When changing the dispersing material, it should be checked if the material of the rotary shaft seal and the O-rings is still suitable. It may be necessary to replace the parts against parts made of other materials.

## 10.2 The generators

The generators (904) of the machine are located above the rotary shaft seal on the drive shaft. The generator is fine-toothed and for this reason quite sensitive.

In case of strongly baking and hardening materials, the generators must be rinsed after operation is completed.

In order to ensure protection of the machine against foreign bodies such as screws, stones, welding beads etc. on the generators, it is recommended that a sieve or filter is placed in front of the machine prior to feeding in substances.

Depending on the abrasiveness of the product to be mixed, the generators are subject to a certain degree of wear. As the size of the shearing gap has an influence on the mixing quality, the tools should be checked for wear from time to time.

## 10.3 The bearings

The bearings, which are sealed on both sides, are filled with a lithium-based grease. The bearings are provided with a lifetime lubrication and are maintenance-free.

## 10.4 Drive shaft

Disassembly of the drive shaft is not necessary in case of intended use of the device. It is for example only necessary to disassemble the drive shaft if bearing or shaft are damaged. In such a case, the IKA service is readily at your disposal or we can deliver a completely premounted bearing lantern as replacement. Repair work may only be carried out by an expert. Should you nevertheless want to repair the device yourselves and have the necessary specialist knowledge, a general description of the individual procedures is given here:

### 10.4.1 Disassembly of the drive shaft

- Disassembly of generator and flange gasket
- Loosen the hexagon head screw (212)
- In order to release the V-belt, unscrew the locking nut (223) and turn the adjusting screw (222) outwards
- Remove V-belt (306) and unscrew hexagon socket set screw (304)
- Pull off V-belt pulley (302), unscrew hexagon head screw (430), and take off lantern
- Unscrew hexagon socket head cap screw (429) and pull off lantern base
- Unscrew hexagon socket set screw (416) and hexagon head screw (410),
- Force adjusting ring (415) and cover (408) off using the bearing cover (412)
- Press drive shaft (426) upwards out of the bearing seat
- Remove circlip (404, 439)
- Force bearing (418, 438) off of the shaft

### 10.4.2 Assembly of drive shaft

Assembly is carried out in reverse order to disassembly.

## 10.5 Tensioning the V-belt

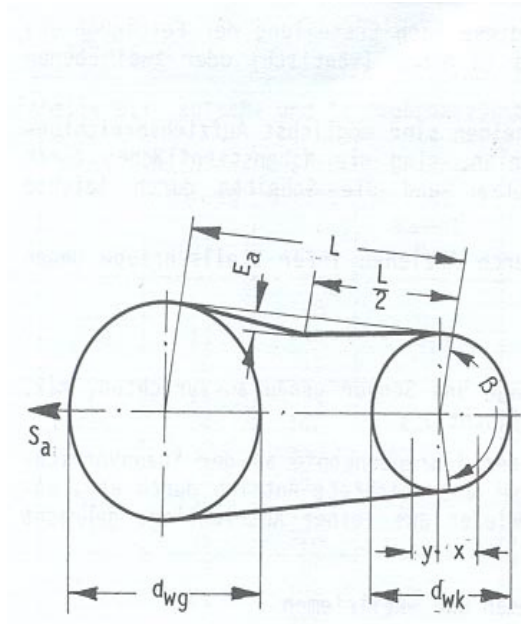

Explanations of the terms

$E$	=	Depth of impression per 100 mm of belt length	mm
$E_a$	=	Depth of impression of the end of the belt	mm
$f$	=	Test load per V-belt	N
$k$	=	Constant to calculate the centrifugal force	
$L$	=	Distance between centres of the drive	mm
$S_a$	=	Minimum axle load in a static condition	N
$v$	=	Belt speed	m/s
$P$	=	Power to be transmitted by the belt drive	kW
$P_B$	=	Calculation power	kW
$c_1$	=	Angular factor	
$c_2$	=	Operating factor	
$x/y$	=	Adjustability of the difference between centres $e_{nom}$	mm
$z$	=	Number of belts	
$\beta$	=	Angle of belt contact of the small pulley	°
$T$	=	Minimum belt force in a static condition per belt	N

$$P_B = P \times c_2$$



**Note**

The belt tension is correct if the belt given an impression force of 7.4 N can be impressed by a value of  $E_a = 4$  mm.

**Increasing the tension:**

The device will be delivered with the correct belt tension. After approx. 4 hours at full load, the initial tension of the V-belt must be checked and, if necessary, the tension must be increased. This way the initial elongation of a new belt is compensated:

**Procedure to increase the tension (see also spare parts drawing 13.2)**

- Disconnect the current supply
- Dismount accessories, such as shut-off valves, hoppers etc.
- Detach piping from the inlet and outlet side
- Lay device down, unscrew the feet
- Unscrew bottom plate
- Loosen motor fixing screws (212), but do not unscrew them!
- Loosen locking nut (223)
- Adjust the belt tension to the specified value using adjusting screw (222)
- Tighten locking nut (223)
- Tighten motor fixing screws (212)
- Screw on bottom plate and feet
- Place the device upright and align it using the feet, check the stability of the device.
- Connect the pipework, if necessary, connect accessories

**Protection against influences of high temperatures, humidity, and chemical substances:**

The V-belt is insensitive to higher or low ambient temperatures. It can easily be used at temperatures of -30 °C up to +70 °C.

The V-belt is electrically conductive (according to DIN 7867), oil-resistant, and partly resistant to weak acids.

**Maintenance and operational safety:**

We recommend to check the V-belt at regular intervals. During this, check the initial tension and, if necessary, correct it. The V-belt does not require special care.

Belt wax or similar agents have a detrimental effect and must absolutely not be used.

The surfaces of the groove faces and the belts must not be dirty.

## 11 Troubles/Causes and troubleshooting

Motor does not start	Motor overload	Strong vibrations	Leakage	inadmissible temperature increase	Unusual noise	too low rate of flow	Cause	Troubleshooting
•							Failure of the mains voltage	Check of the voltage supply by authorised personnel
•							Voltage supply off	Plug in the plug, main switch ON
•							Activation of the temperature monitoring of the motor	Let motor cool down, reduce motor load
	•						Motor only runs with 2 phases	Check electrical connection
•	•						high viscosity of the product or unfavourable rheological product characteristics	Throttle rate of flow, reduce speed
	•						High speeds, particularly with Dispax Reactor ® DR module	Reduce speed
	•	•			•		Eccentricity of the shaft	Align or replace shaft
		•			•		Unbalance of the mixing tool(s) possibly due to baking product or wear	Clean rotating parts, if necessary, rebalance or replace them, replace worn parts
		•			•		Bearing defective	Replace bearing
		•			•		Motor mounting defective	Replace mounting or motor
		•					Device badly aligned	Realign device
			•				Rotary shaft seal on the product side leaks	Replace rotary shaft seal
			•				Static O-ring seal between the housing parts leaks	Place O-rings carefully into the groove and replace them if damaged
			•				Flanged connections leak	Retighten the connection, replace defective seals
				•			Outlet valve closed while machine is running	Do not keep the valve closed for a longer period



Motor does not start	Motor overload	Strong vibrations	Leakage	inadmissible temperature increase	Unusual noise	too low rate of flow	Cause	Troubleshooting
				•			Prolonged circulating operation with high output	Connect a cooling unit at the circulating hopper
				•			Speed too high	Reduce speed
				•			Ambient temperature too high	Improve ventilation
					•		V-belt sings	Increase the V-belt tension
					•		Foreign bodies in the mixing chamber	Clean machine and check parts for damages
						•	Pump delivers against too high pressure	Further open the control valve, reduce resistance of the pipework
						•	Supply line or mixing chamber clogged up	Remove deposits in the machine and/or pipework
						•	trapped air in the mixing chamber or suction pipe, particularly in case of horizontal suction pipe	Vent device and/or suction pipe
						•	Wrong direction of rotation	Change 2 phases of the current supply
						•	too low speed	Increasing the speed
	•					•	Wear of the interior parts	Replace worn parts
						•	no belt tension	Tension belt or, if worn, replace it



## 12 Ordering spare parts

Please use the form below to order spare parts. This enables us to handle merchandise swiftly and smoothly.

Please proceed as follows:

Please indicate your full address and the address to which the goods should be delivered (if different).

Please enter the part you require in the table below. The exact designation can be obtained from the piece lists. Please always indicate the item, the designation, and the order number.

### Example:

Order

Serial number:

Invoice address:

.....

.....

.....

Item	Quan-	Unit	Order no.	Designation

## 13 Spare parts list and drawings:

### 13.1 Machine spare parts list

POS	Part #	Description	QTY
100	P005002	MOT,2HP,#56-C,230/460/3/60/3600+	1
104	P005117	SCREW,SH CTSK,316SS,3/8INNCX.75IN+	3
110	S11XXACAAAAXX4 X	UTL 2000/4+	1
202	R20-097905	FRAME,BASE,SS,2000/4	1
204	R1052672	FOOT,ADJ,M12,W/RUBBER,2000/4	4
206	R24-097915	INSERT,THREADED,316SS,M8XM12	4
210	P005158	PLATE,MTG,MOTOR,SS,56C,2000/4	1
212	P005119	SCREW,SH CTSK,316SS,M10X16+	4



214	R24-097922	NUT,TEE,STL,M10,MOT ADJ,2000/4	4
216	P005510	SCREW,SH CTSK,316SS,M6X16+	2
217	R24-097923	BLOCK,MOTOR,ADJ,316SS,2000/4	1
222	P005511	SCREW,HHC,316SS,M6X35+	1
223	P004720	NUT,HEX,316,M6	1
230	P001413	SCREW,SHC,LOW HEAD,316SS,M5X12+	4
232	R23-097921	PLATE,COVER,BOTTOM,2000/4	1
302	R1054790	SHV,56MM,ALUM,16MM,UNIT,2000/4	1
304	P003175	SCREW,SKT SET,CON PT,316SS,M8X8+	2
306	R1057758	BELT,MICRO V,711 PJ-04-EL,2000/4	1
310	R1057753	SHV,125MM,ALUM,.625IN,2000/4 60HZ	1
402	P001049	KEY,PARALLEL,316SS,4X4X45	1
404	P005505	RING,RTNG,EXT,304SS,20X1.2+	1
408	R24-097904	SEAL,CENTRIFURAL,316SS,2000/4	1
410	P005504	SCREW,HHC,316SS,M5X12+	3
412	R24-097899	CAP,BRG,UNIT SIDE,SS,2000/4	1
415	R24-097917	COLLAR,SHAFT,316SS,2000/4	1
416	P005506	SCREW,SKT SET,CON PT,304,M4X4+	1
417	R24-097928	SPACER,BRG DIST,316SS,2000/4	1
418	P002452	BEARING,BALL,2X RUBR SHLD,20X42X12+	2
422	R24-097872	PLATE,SEAL COVER,316SS,2000/4	2
424	P004936	SCREW,SHC,LOW HEAD,316SS,M4X10	4
426	R23-097876	SHAFT,DRIVE,2000/4,316SS,L3	1
427	R23-097838	FLG,LTRN,BASE,316SS,2000/4	1
428	R22-097839	FLG,LTRN,316SS,2000/4	1
429	P005507	SCREW,SHC,316SS,M6X20+	4
430	P005203	SCREW,HHC,316SS,M8X16+	4
432	P005509	KEY,PARALLEL,316SS,5X5X22+	1
434	P000020	FTG,PIPE,PLUG,SH,SS,R1/8IN+	3
438	R1052690	BEARING,BALL,2XRUBR SHLD,17X35X10+	1
439	P005508	RING,RTNG,EXT,304SS,17X1+	1
500	P005503	HOUSING,SEAL,2000/4	1
501	R1054617	SEAL,RDL SFT,PTFE,2000/4	1
502	R1057196	RING,RTNG,INT,SS,28X1.2+	1
600	P005123	ORING,SET,VIT,UTL2000/4	1
608	P004440	ORING,VIT,101.32X1.78+	2
610	P004878	ORING,VIT,69.57X1.78	2
612	P004879	ORING,VIT,50.52X1.78	1
614	P005096	ORING,VIT,8X3	2
620	P004880	ORING,VIT,20.35X1.78	1
622	P004574	ORING,VIT,28.3X1.78+	1
624	P004704	ORING,VIT,10X1+	2
704	R1056121	FLG,INLET,1IN S-FTG,2000/4	1
710	R1056118	CHAMBER,DISP,.75 S-FTG,2000/4	1





---

720	R24-097206	NUT,HEX,CAP,316SS,M8,W/ORING GRV	2
722	R24-097866	STUD,316SS,M8X70(80),UTL2000/4	2
730	R24-097892	NUT,HEX,CAP,316SS,M8,2000/4	1
732	R24-097900	SPACER,ROTOR	1
904	R23-098032	ROTOR,MDM(4M),316SS,2000/4	1
905	R24-097916	SPACER,ROTOR,DIS,316SS,2000/4	1
906	R23-098031	STATOR,MDM(4M),316SS,2000/4	1
1100	R1056538	SET,TOOL,2000/4	1
1200	P005092	LABEL,SET,2000/4	1
1202	P001066	LABEL,DIRECTION ARROW	1
1204	P001070	LABEL,PROCESSING EQUIP,IKA WORKS	1
1208	P004885	LABEL,SERIAL NO,304SS,2000 SERIES	1
1218	P002428	LABEL,SERIAL NUMBER,SMALL	1

13.2 Figure 3 Machine spare parts drawing

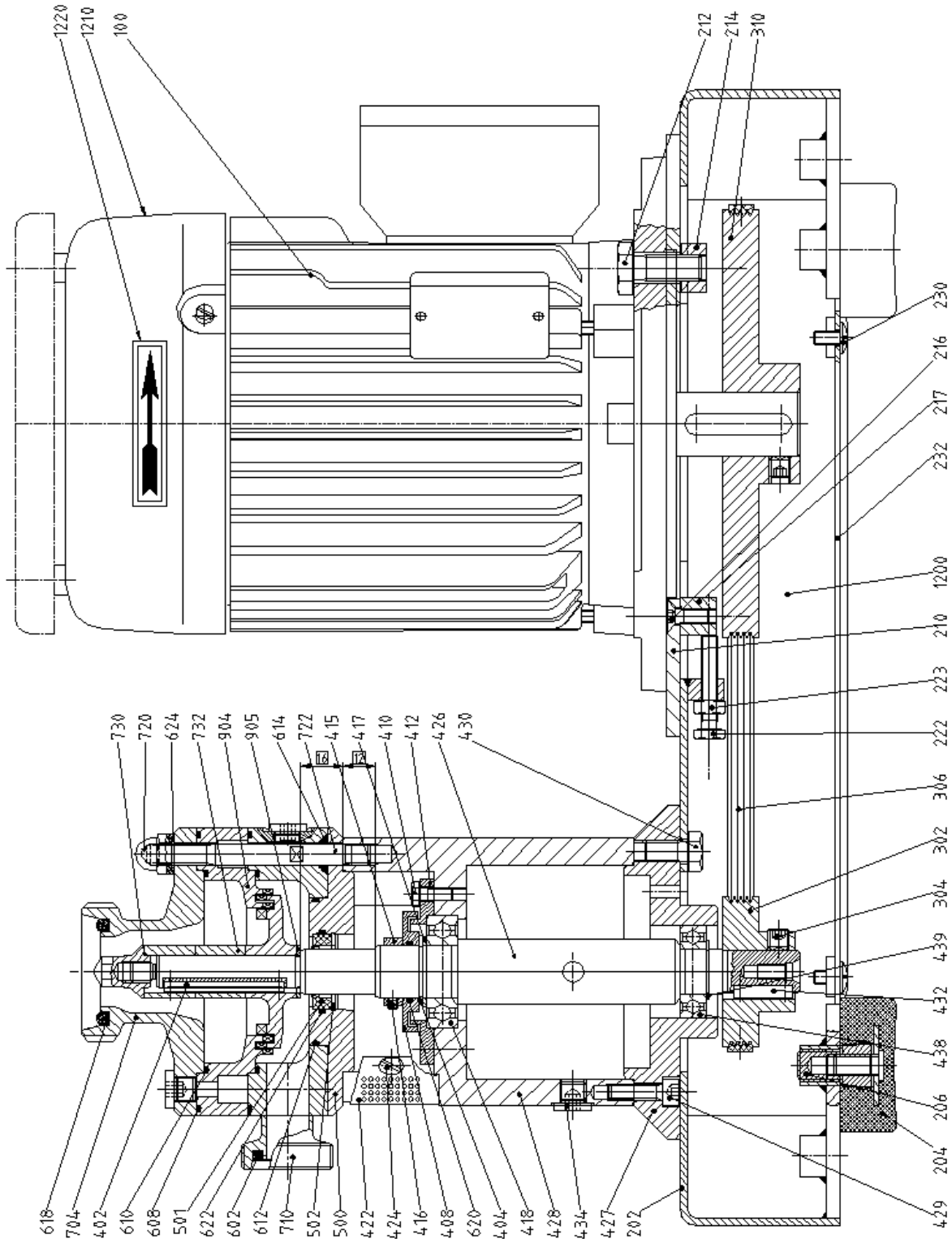

13.2.1 Figure 4 Detail of figure 3

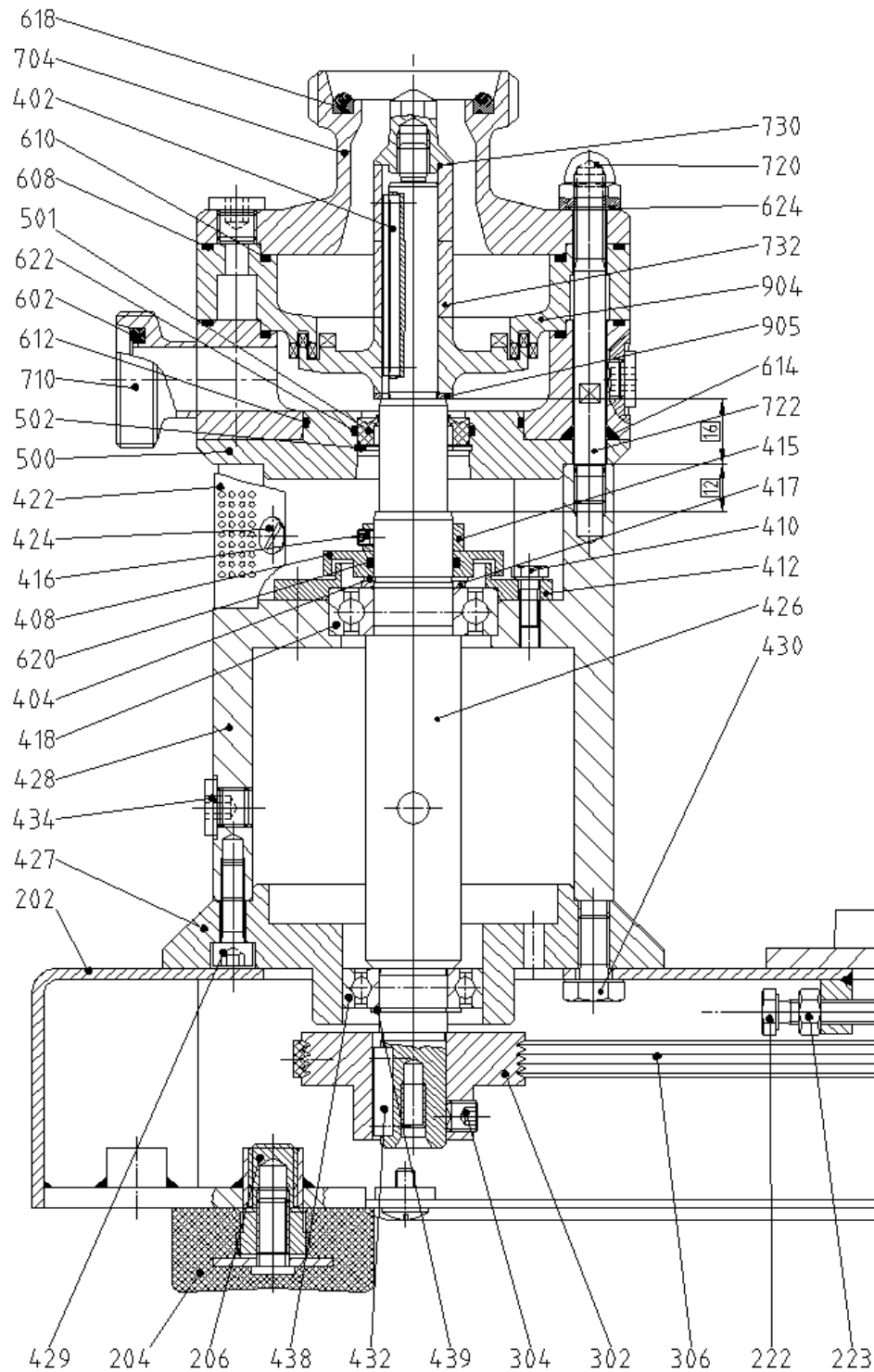

13.2.2 Figure 5 Detail of figure 3

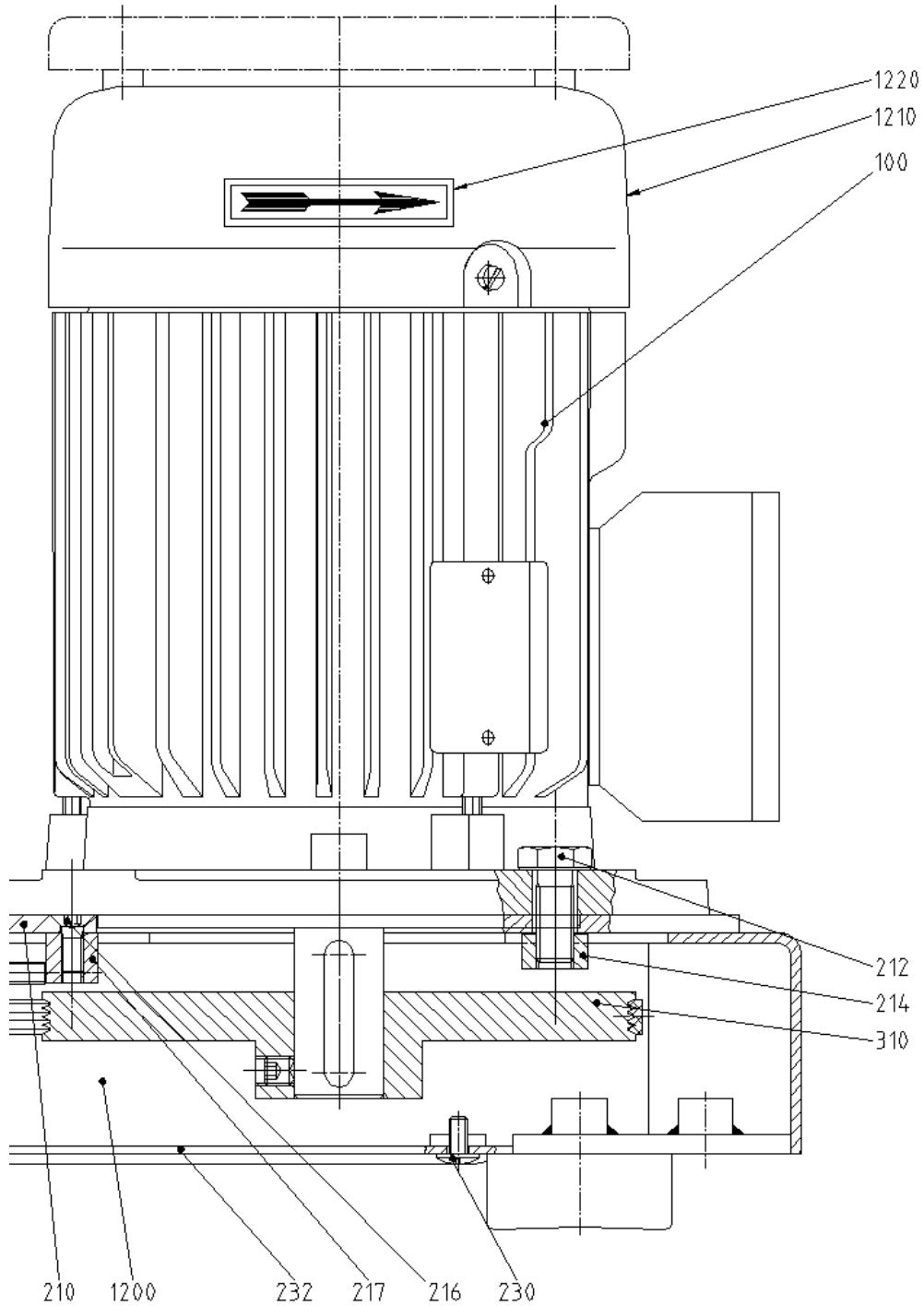

**13.3****13.4- DR Module Spare parts list and drawing**

Item	Quan-	Unit	Order no.	Designation
608	2	pc.	P004440	ORING,VIT,101.32X1.78
610	2	pc.	P004878	ORING,VIT,69.57X1.78
722	2	pc.	R24-098035	STUD,316SS,M8X110(120) DR2000/4
804	1	pc.	R23-098027	ROTOR,CRS(2G),316SS,2000/4
806	1	pc.	R23-098026	STATOR,CRS(2G),316SS,2000/4
1004	1	pc.	R23-097869	ROTOR,FINE(6F),316SS,2000/4
1006	1	pc.	R23-097853	STATOR,FINE(6F),316SS,2000/4

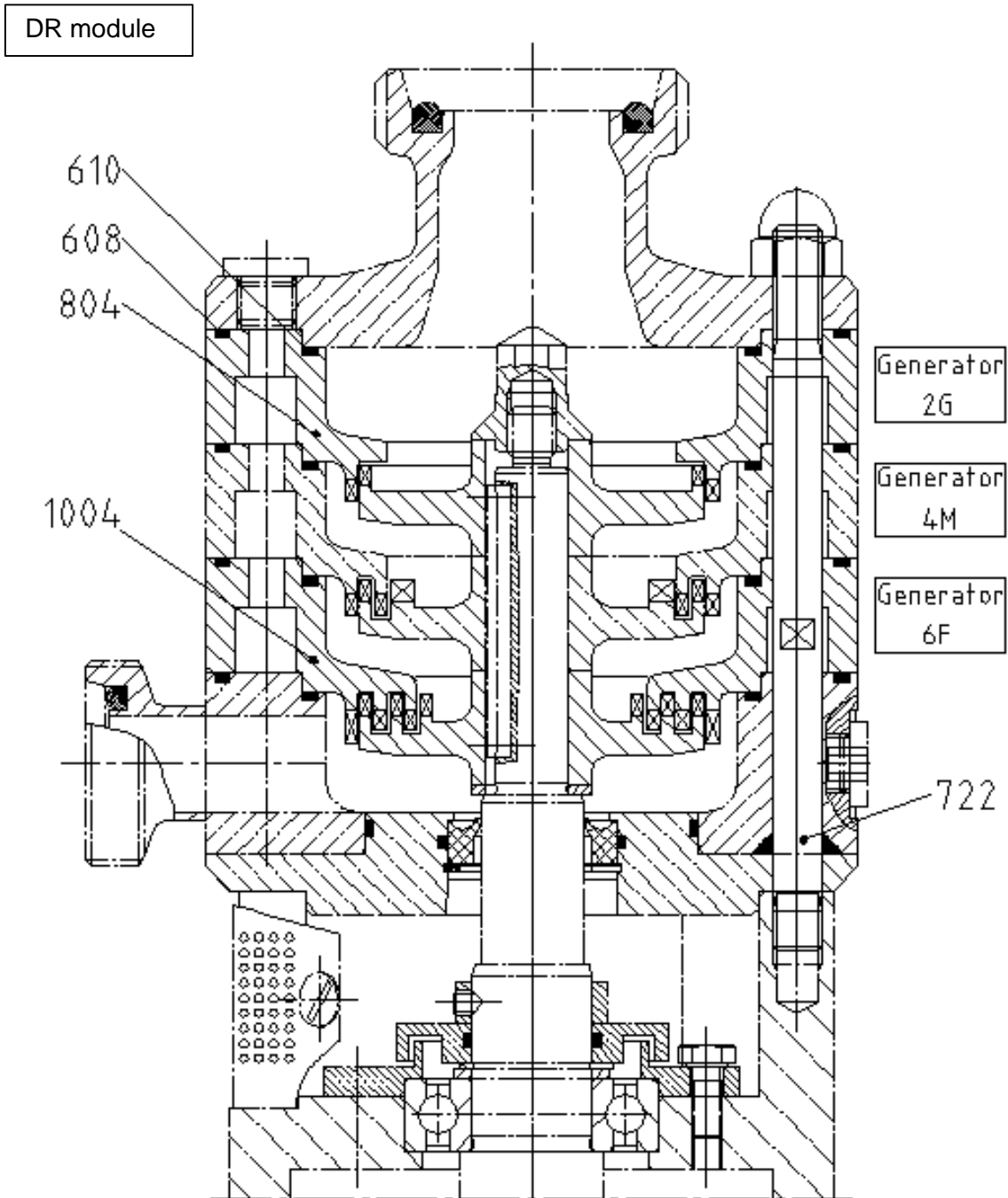

The following table specifies the speed range to operate the DR module. It is recommended that you operate within these specifications. Exceeding these ranges may result in mechanical failure

Module	SHAFT/RPM	Hz	MOTOR/RPM	M/sec.
DR	3140-7900	24-60	1440-3600	8.5-23

**13.5 - MHD Module Spare parts list and drawing**

Item	Quan-	Unit	Order no.	Designation
608	2	pc.	P004440	ORING,VIT,101.32X1.78
610	2	pc.	P004878	ORING,VIT,69.57X1.78
625	1	pc.	P005160	ORING,VIT,53.57X3.53
704	1	pc.	R1056121	FLG,INLET,1IN S-FTG,2000/42000/4
708	1	pc.	R1057350	FLG,INLET,.75"S-FTG,LIQ,MHD2000/4
722	2	pc.	R24-098035	PADDLE,A,316SS,45DEG,MHD2000/4
802	1	pc.	R24-098037	Feeding screw Ø47-1SA DN 50
804	2	pc.	R23-098027	ROTOR,CRS(2G),316SS,2000/4
806	1	pc.	R24-098038	PADDLE,B,316SS,45DEG,MHD2000/4
902	1	pc.	R24-098040	MANTLE,(CRS)5MM DIA,MHD2000/4
1004	1	pc.	R23-098034	ROTOR,CRS(1P),316SS,MHD2000/4
1006	1	Pc.	R23-098026	STATOR,CRS(2G),316SS,2000/4

MHD mod-

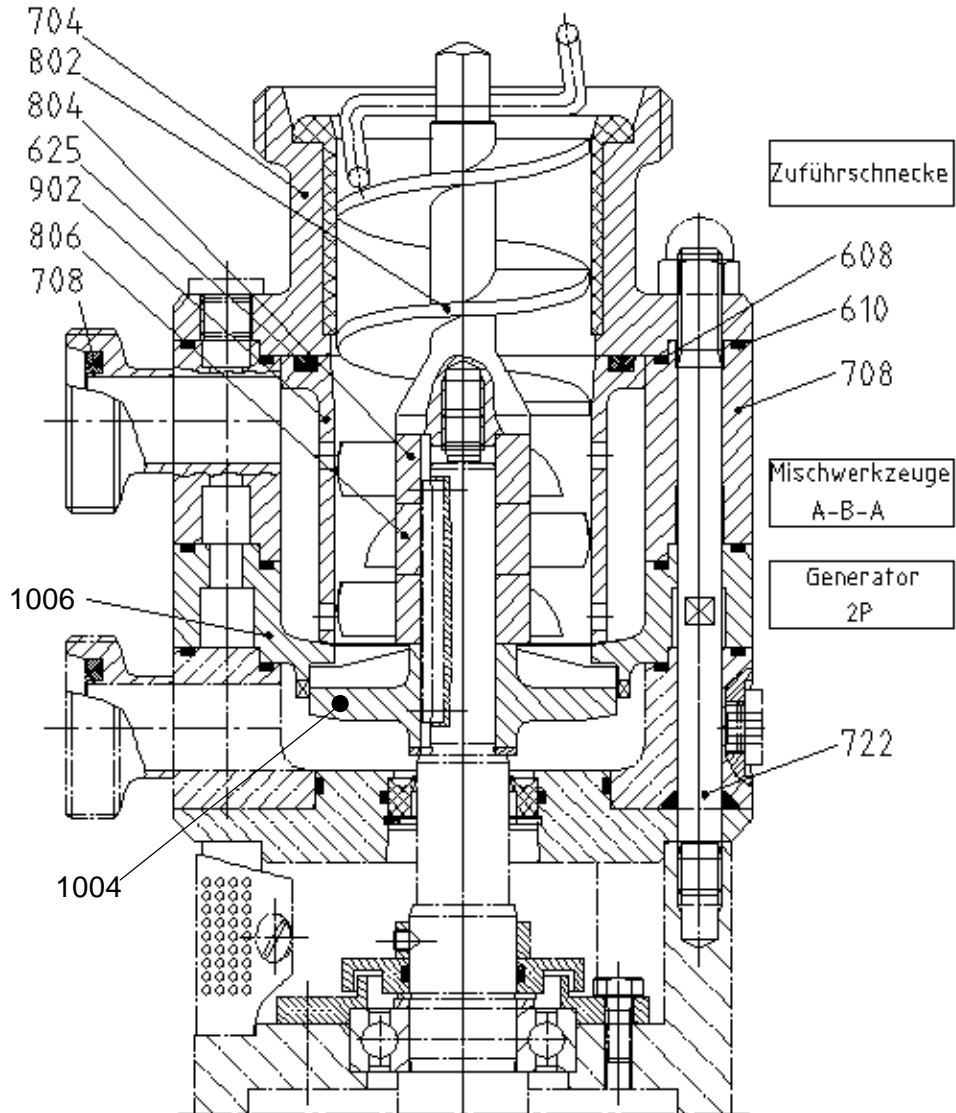

The following table specifies the speed range to operate the MHD module. It is recommended that you operate within these specifications. Exceeding these ranges may result in mechanical failure.

Module	SHAFT/RPM	Hz	MOTOR/RPM	M/sec.
MHD	3140-7900	24-60	1440-3600	8.5-23



### 13.6 - MK Module Spare parts list and drawing

Item	Quan-	Unit	Order no.	Designation
603	1	pc.	1050493	O-ring FPM 58.42x2.62
604	1	pc.	1055255	O-ring FPM 42.52x2.62
614	2	pc.	1053789	O-ring FPM 8x3
626	1	pc.	1055256	O-ring FPM 66.34x2.62
627	1	pc.	S104861	Seal G
630	2	pc.	1050460	O-ring FPM 9.25x1.78
704	1	pc.	1054919	Inlet flange DN25 DIN11851
712	2	pc.	S100692	Hexagon head screw DIN 933 M6x10-A2
716	1	pc.	1055068	Adjusting ring
718	1	pc.	1054918	Pressure plate
722	2	pc.	S098035	Stud bolt M8x110
728	1	pc.	1055015	Housing
734	2	pc.	S104317	Star knob screw GN6336.5-ST-32-M6-20
736	2	pc.	1045338	Hexagon nut DIN 439 M6-A2
740	2	pc.	1034421	Hexagon socket head cap screw DIN 912 M5x12-A2
904	1	pc.	1055160	Rotor part 1, z=32
906	1	pc.	1055182	Stator part 1, z=34
1004	1	pc.	1055179	Rotor part 2, z=75
1006	1	pc.	1055192	Stator part 2, z=80

MK module

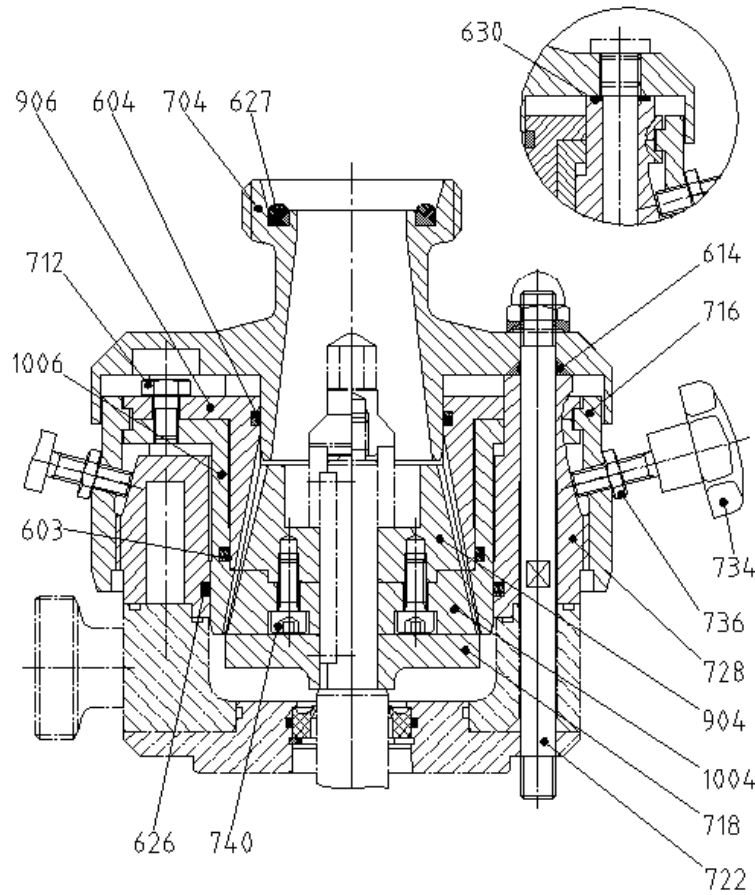

The following table specifies the speed range to operate the MK module. It is recommended that you operate within these specifications. Exceeding these ranges may result in mechanical failure.

Module	SHAFT/RPM	Hz	MOTOR/RPM	M/sec.
MK	3140-7900	24-60	1440-3600	8.5-23

## 14 Appendix

### 14.1 Scale-Up

The LABOR-PILOT is designed in the same way as the larger production machines of the 2000 series. All important parameters can be transferred to the larger machines and thus enable an optimum scale-up to pilot or production plants. The following table gives a survey of the individual machines:



Machine type	Throughput liters/h	Power kW
<b>Single-stage dispersing machines ULTRA TURRAX® INLINE UTL</b>		
LABOR-PILOT 2004	350	1,5
UTL 2000/05	2500	4
UTL 2000/10	8000	7,5
UTL 2000/20	20000	22
UTL 2000/30	40000	37
UTL 2000/40	70000	55
UTL 2000/50	125000	110
<b>Three-stage dispersing machines DISPAX REACTOR® DR</b>		
LABOR-PILOT 2004 incl. DR module (7900 rpm)	350	1,5
DR 2000/50	2500	5,5
DR 2000/10	8000	15
DR 2000/20	20000	37
DR 2000/30	40000	55
DR 2000/40	70000	90
DR 2000/50	125000	160
<b>Three-stage dispersing machines with par- ticularly high circumferential speeds Super DISPAX REACTOR® DRS</b>		
LABOR-PILOT 2004 incl. DR module (13700 rpm)	550	1,5
DRS 2000/05	1200	7,5
DRS 2000/10	2500	15
DRS 2000/20	7500	37
DRS 2000/30	20000	75
DRS 2000/50	40000	200

Machine type	Throughput liters/h	Power kW
<b>Mixing of powder with liquids MHD ma- chines</b>		
LABOR-PILOT 2004 incl. MHD module	100	1,5
MHD 2000/05	750	4
MHD 2000/10	2500	7,5
MHD 2000/20	7500	15
MHD 2000/30	20000	30
MHD 2000/50	40000	75
<b>Colloid mill MK</b>		
LABOR-PILOT 2004 incl. MK module	300	1,5
MK 2000/05	2500	4
MK 2000/10	7500	11
MK 2000/20	20000	22
MK 2000/30	40000	45
MK 2000/50	80000	90



Europa – Afrika

**IKA<sup>®</sup> WERKE**

---

LABORTECHNIK  
ANALYSENTECHNIK  
MASCHINENBAU

**IKA<sup>®</sup> WERKE GmbH & Co. KG**  
Janke & Kunkel-Str. 10  
D 79219 Staufen  
GERMANY  
TEL.: 07633/831-0  
FAX: 07633/831-98  
E-mail: [sales@ika.de](mailto:sales@ika.de)  
Internet: <http://www.ika.net>  
<http://www.ikaprocess.com>

America

**IKA<sup>®</sup> WORKS, INC.**

---

LABOR- TECHNOLOGY  
ANALYZING TECHNOLOGY  
PROCESSING EQUIPMENT

**IKA<sup>®</sup> WORKS, INC.**  
2635 NORTH CHASE PKWY, SE  
WILMINGTON, NC 28405-7419  
TEL.: 800/733-3037  
TEL.: 910/452-7059  
FAX: 910/452-7693  
E-mail: [process@ika.net](mailto:process@ika.net)

Asien - Australien

**IKA<sup>®</sup> WORKS, (Asia) Sdn Bhd**

---

LABOR- TECHNOLOGY  
ANALYZING TECHNOLOGY  
PROCESSING EQUIPMENT

**IKA<sup>®</sup> WORKS (Asia) Sdn Bhd**  
(Company No. 340448-K)  
No. 3, Lot PT 3403,  
Batu 22 ¾ Lebu Raya,  
Kuala Lumpur- Serendah,  
48200 Serendah  
Selangor, Malaysia  
TEL.: (603) 601 3122  
FAX: (603) 601 3126  
E-mail: [ika@tm.net.my](mailto:ika@tm.net.my)

---

<http://www.ikaprocess.com>

---