

Degree: Bachelor of Arts | Double Major: _____ + Education | Certification: Grades 7 - 12 | 121 Hours

The degree requirements below are outlined in the 2025 Undergraduate Catalog and will remain valid through summer 2031.

Institutional Requirement (1 hour)	Texas State Catalog Degree Plan	Transfer Equivalency (TCCN)
University Seminar	US 1100	Waived for transfer students with 16+ hours.
Bachelor of Arts (BA) Requirements (12-20 hours)		
Modern Language	Modern Language 2310 + 2320	Modern Language 2311 + 2312
Can earn credit for Modern Language via the College Level Examination Program (CLEP) or through Advanced Placement (AP). Most students will need to complete Modern Language 1410 + 1420 (TCCN 1411 and 1412) to access Intermediate Language courses.		
Additional Science	030 Course Different from Core	030 Course Different from Core
Additional English Literature	ENG 2310-2360	ENG 2322, 2323, 2327, 2328, 2332, or 2333
Program-Specific Core Curriculum (3 hours; additional Program-Specific Core courses may be required, depending on the double Major declared)		
090 Component Area (3 hours)	COMM 1310~	SPCH 1311 or 1315 or 1318~
General Education Core Curriculum (39 hours) refer to the undergraduate catalog for core curriculum options		
010 Communication (6 hours)	010 Course* 010 Course*	010 Course* 010 Course*
020 Mathematics (3 hours)	020 Course*	020 Course*
030 Life and Physical Sciences (6 hours)	030 Course 030 Course	030 Course 030 Course
040 Language, Philosophy, and Culture (3 hours)	040 Course* (WI)	040 Course*
050 Creative Arts (3 hours)	050 Course	050 Course
060 American History (6 hours)	060 Course* (WI) 060 Course* (WI)	060 Course* 060 Course*
070 Government/Political Science (6 hours)	070 Course* 070 Course*	070 Course* 070 Course*
080 Social and Behavioral Sciences (3 hours)	080 Course	080 Course
090 Component Area (3 hours)	090 Course (WI)	090 Course
MAJOR I: Content-Area (33 hours)		
History (Social Studies), English, French, German, or Spanish		
This program is intended for students seeking teacher certification in select high school subject areas. Students wanting to teach the subjects listed above should consult with The College of Liberal Arts Advising Center (512-245-1852).		
MAJOR II: Education (33 hours)		
Education for Change	CI 2310*	EDUC 1301*
Adolescents & Society	CI 3325*	
Teaching for Linguistic Diversity	CI 3340*	
Secondary Teaching: Curriculum and Technology	CI 4332*	
Community-Based Instructional Strategies for the Secondary Teacher	CI 4343*	
Building Relationships in the Secondary Classroom	CI 4370*	
Teaching in Secondary Classrooms	CI 4372*	
Clinical Teaching	EDST 4681	
Teaching Literacies in the Content Areas	RDG 3323*	
Educating Students with Mild Disabilities	SPED 4344*	EDUC 2301*
Educator Preparation Program Requirements		
'C' or better in: • 010 Core • 020 Core • 040 Core • 060/070 Core (2 of 4 must be 'C' or better)		
'B' or better in 090 Core COMM/SPCH; if 'C' is earned student can pursue appeal with the Office of Educator Preparation		
Junior Classification (60+ earned credit hours)		
2.75 Overall GPA		
Comments		
~ Requires grade of 'B' or better		
* Requires grade of 'C' or better		
† CC/JC may require 4-hour course with lab; lab is not required at TXST and will be considered an "open elective" towards your degree		
(WI) Writing Intensive		
In addition to successful completion of all required coursework, students must satisfy GPA and residency requirements to graduate.		
Students should avoid enrolling in more than 72 CC/JC hours without prior consultation with an academic advisor.		

Degree: Bachelor of Arts | Double Major: _____ + Education | Certification: Grades 7 through 12

The sequencing below reflects course prerequisites that are subject to change each academic year.
For use in planning **Fall 2025**, **Spring 2026**, and **Summer 2026** semesters.

PRIORITY DUE TO SEQUENCING

Prioritize these courses in your schedule each semester

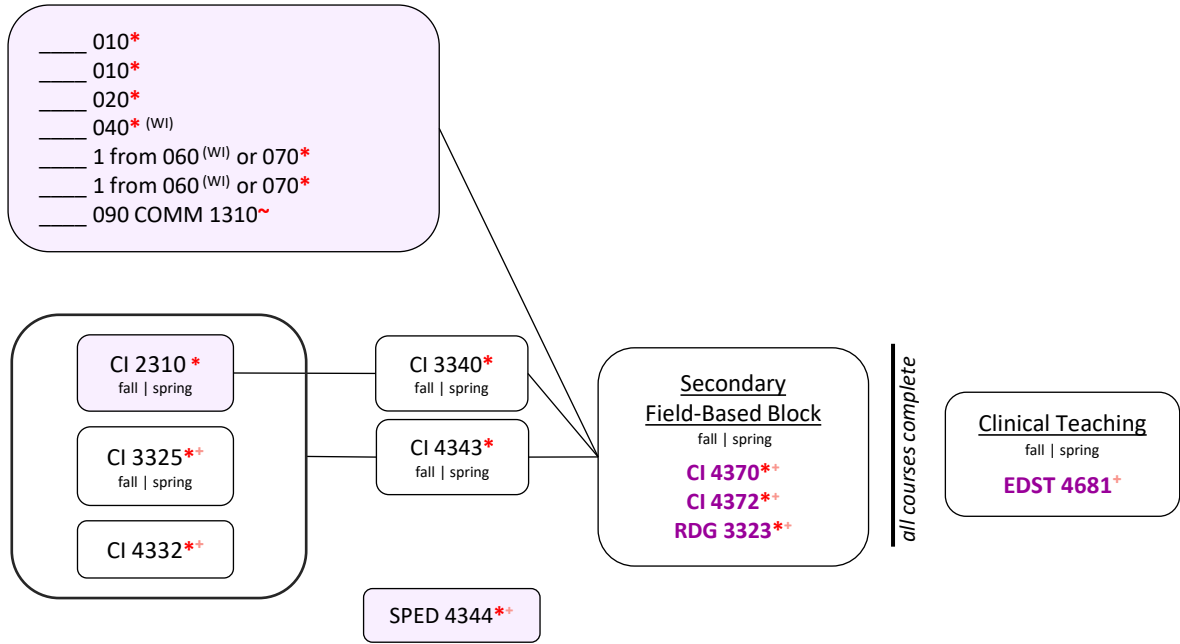

ADDITIONAL REQUIRED COURSES

Use these courses to fill remaining space in your schedule each semester

Core Curriculum

- ___ 030
- ___ 050
- ___ 060 (WI) or 070
- ___ 060 (WI) or 070
- ___ 080
- ___ 090B (WI)

Additional BA Requirements

- ___ Modern Language 1410
- ___ Modern Language 1420
- ___ Modern Language 2310
- ___ Modern Language 2320
- ___ Science
- ___ English Literature

Major 1: 33 hours

- | | |
|--------------------------------|--------------------------------|
| <input type="checkbox"/> _____ | <input type="checkbox"/> _____ |
| <input type="checkbox"/> _____ | <input type="checkbox"/> _____ |
| <input type="checkbox"/> _____ | <input type="checkbox"/> _____ |
| <input type="checkbox"/> _____ | <input type="checkbox"/> _____ |
| <input type="checkbox"/> _____ | <input type="checkbox"/> _____ |

US 1100

GPA restricted (2.75 Overall) | * requires grade of 'C' or better | ~ requires grade of 'B' or better | + classification restriction | (WI) Writing Intensive

PURPLE: if planning to complete courses at a transfer institution, refer to the first page for transfer equivalency
In addition to successful completion of all required coursework, students must satisfy GPA and residency requirements to graduate.