

**Degree:** Bachelor of Science | **Major:** Recreation and Sport Management  
**Concentration:** Outdoor Recreation | **Minor:** selected from catalog | **120 Hours**

The degree requirements below are outlined in the 2025 Undergraduate Catalog and will remain valid through summer 2031.

| Institutional Requirement (1+ hours)   | Texas State Catalog Degree Plan  | Transfer Equivalency (TCCN)                     |
|--|--|---|
| <b>University Seminar</b>  | US 1100  | Waived for transfer students with 16+ hours.    |
| <b>Foreign Language Proficiency</b>  | <i>Consult with TXST advisor to determine if coursework is required</i>  |   |
| <b>Program-Specific Core Curriculum (3 hours)</b>  |  |   |
| <b>080 Social and Behavioral Sciences (3 hours)</b>  | PFW 1301   | PSYC 2301 or SOCI 1301 (approved substitutions) |
| <b>General Education Core Curriculum (39 hours)</b> refer to the undergraduate catalog for <a href="#">core curriculum options</a> |  |   |
| <b>010 Communication (6 hours)</b>   | 010 Course<br>010 Course   | 010 Course<br>010 Course                        |
| <b>020 Mathematics (3 hours)</b>   | 020 Course   | 020 course                                      |
| <b>030 Life and Physical Sciences (6 hours)</b>  | 030 Course<br>030 Course   | 030 Course<br>030 Course                        |
| <b>040 Language, Philosophy, and Culture (3 hours)</b>   | 040 Course <sup>(WI)</sup>   | 040 Course                                      |
| <b>050 Creative Arts (3 hours)</b>   | 050 Course   | 050 Course                                      |
| <b>060 American History (6 hours)</b>  | 060 Course <sup>(WI)</sup><br>060 Course <sup>(WI)</sup>   | 060 Course<br>060 Course                        |
| <b>070 Government/Political Science (6 hours)</b>  | 070 Course<br>070 Course   | 070 Course<br>070 Course                        |
| <b>090 Component Area (6 hours)</b>  | 090 Course<br>090 Course <sup>(WI)</sup>   | 090 Course<br>090 Course                        |
| <b>Major (24 hours)</b>  |  |   |
| Introduction to Recreation and Sport Management  | REC 1310*  | PHED 1336*                                      |
| Leadership in Recreation and Sport Services  | REC 2330   |   |
| Recreation and Sport Program Development   | REC 2335*  |   |
| Field Experience in Recreation and Sport Programming   | REC 2336*  |   |
| Recreation & Sport Administration & Management   | REC 3325*  |   |
| Evaluation of Recreation and Sport Programs  | REC 3351 <sup>(WI)</sup>   |   |
| Employee Supervision in Rec. and Sport Management  | REC 4350   |   |
| Seminar in Recreation and Sport Trends and Issues  | REC 4380* <sup>(WI)</sup>  |   |
| <b>Concentration (29 hours)</b>  |  |   |
| Cultural Geography Elective  | GEO 1309 or GEO 1310   | GEOG 1302 or GEOG 1303                          |
| Physical Geography Elective  | NHT 4301, GEO 3329, GEO 4326, or PH 3301   |   |
| Introduction to Outdoor Recreation   | REC 1330   |   |
| Introduction to Recreational Therapy   | REC 1370   |   |
| Advanced Recreation & Sport Program Dev.   | REC 3335   |   |
| Entrepreneurial Management in Recreation and Sport   | REC 4330   |   |
| Outdoor Recreation Programming   | REC 4335   |   |
| PFW Electives  | 2 from PFW 1154B/C; PFW 1190A/B/C  |   |
| Internship or Practicum or Electives   | 6 hours from ESS 4357 or REC 3380 or REC 4680 or approved elective(s) – see advisor                                  |   |
| <b>Support (6 Hours)</b>   |  |   |
| 6 Hours of Open Electives  | <i>Open electives may be needed to reach 120 total hours; see advisor prior to enrolling in elective coursework.</i> |   |
| <b>Minor (18+ hours)</b>   |  |   |

See the [undergraduate catalog](#) for a full list of minor options.

**Comments**

\* Requires grade of 'C' or better  
 † CC/JC may require 4-hour course with lab; lab is not required at TXST and will be considered an "open elective" towards your degree  
 (WI) Writing Intensive  
 This degree program requires a 2.0 Texas State GPA, 2.25 Major GPA, and 2.0 Minor GPA to graduate.  
 Students should avoid enrolling in more than 72 CC/JC hours without prior consultation with an academic advisor.

Degree: Bachelor of Science | Major: Recreation and Sport Management  
 Concentration: Outdoor Recreation | Minor: selected from catalog | 120 Hours

The sequencing below reflects course prerequisites that are subject to change each academic year.  
 For use in planning **Fall 2025, Spring 2026, and Summer 2026** semesters.

### PRIORITY DUE TO SEQUENCING

Prioritize these courses in your schedule each semester

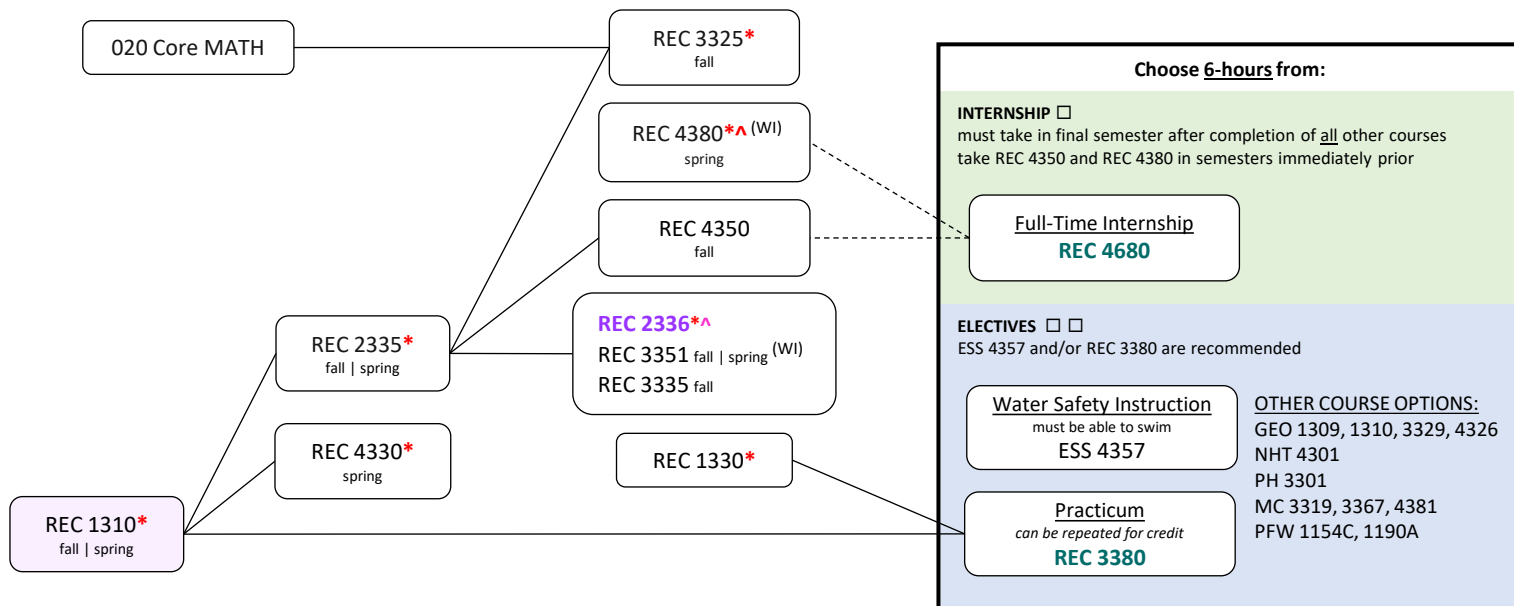

Summer offerings of REC courses are generally limited. Students are advised to prioritize REC courses in fall/spring semesters when possible.

### ADDITIONAL REQUIRED COURSES

Use these courses to fill remaining space in your schedule each semester

#### Core Curriculum

- \_\_\_ 010
- \_\_\_ 010
- \_\_\_ 030
- \_\_\_ 030
- \_\_\_ 040 (WI)
- \_\_\_ 050
- \_\_\_ 060 (WI)
- \_\_\_ 060 (WI)
- \_\_\_ 070
- \_\_\_ 070
- \_\_\_ PFW 1301
- \_\_\_ 090A
- \_\_\_ 090B (WI)

#### Major | Concentration

- \_\_\_ REC 1370
- \_\_\_ REC 2330 fall/spring
- \_\_\_ REC 4335 spring [summer option with [Study in America](#)]
- Cultural Geography Elective** - select one from:  
GEO 1309 fall/spring, GEO 1310
- Physical Geography Elective** - select one from:  
NHT 4301 fall, GEO 3329 spring, GEO 4326 \* fall,  
PH 3301 fall/spring
- PFW Electives** - select two from:  
 PFW 1154B, 1154C, 1190A fall/spring, 1190B,  
1190C

#### Minor

- \_\_\_\_\_  \_\_\_\_\_
- \_\_\_\_\_  \_\_\_\_\_
- \_\_\_\_\_  \_\_\_\_\_
- \_\_\_\_\_  \_\_\_\_\_
- \_\_\_\_\_  \_\_\_\_\_

#### Total Hours Electives

[to reach 120 total; 36 advanced hours]

\_\_\_\_\_

\_\_\_\_\_

\_\_\_\_\_

- US 1100
- Foreign Language Proficiency

GPA restricted (2.0 Texas State; 2.25 Major) | \* requires grade of 'C' or better | ^ classification restriction | (WI) Writing Intensive | ^ Instructor Approval

**PURPLE:** if planning to complete courses at a transfer institution, refer to the first page for transfer equivalency

This degree program also requires a 2.0 Texas State GPA, 2.25 Major GPA, and 2.0 Minor GPA to graduate.