

# E1.05 - Radiant Streets

**Alex Conti**  
**Marko Milosevic**  
**Stephen Peterson**  
Advisor: Jeff Stevens



## Design Overview

Radiant Streets is a traffic light system that detects oncoming traffic and communicates between each other to optimize traffic. Once completed, our traffic light system will be used to direct autonomous vehicles along a simulation of a city street. This will allow the testing of autonomous vehicles in a safe, controlled environment.

## D1 Requirements

- Create two or more traffic lights that communicate between each other along a 4-way intersection.
- Relay information regarding arrivals and departures of vehicles to other lights within the system.
- OpenPLC ladder logic to determine the timing and edge cases of the light system.

## Top Level Block Diagram

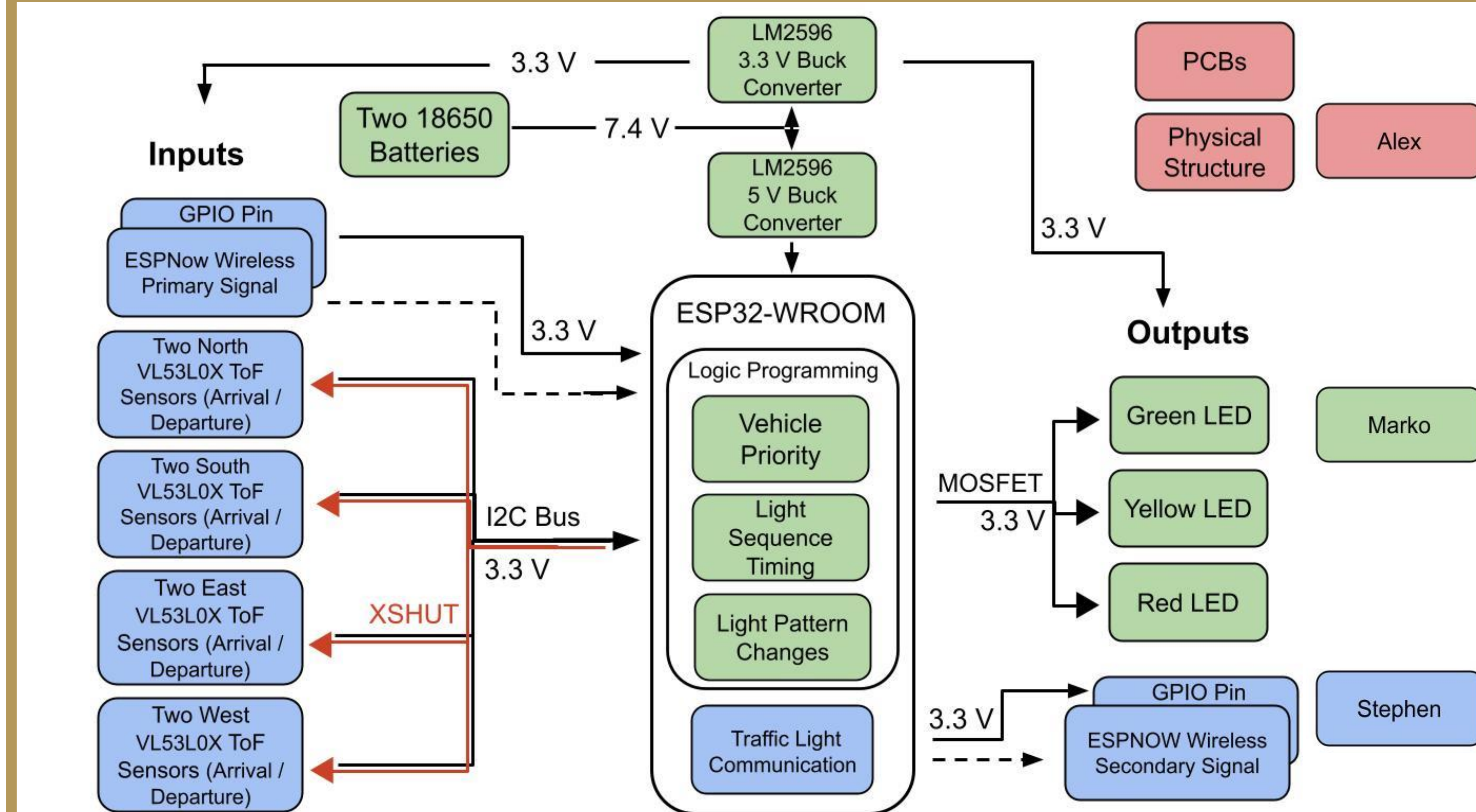

## Meet the Team



Marko Milosevic      Alex Conti      Stephen Peterson

## Vehicle Detection

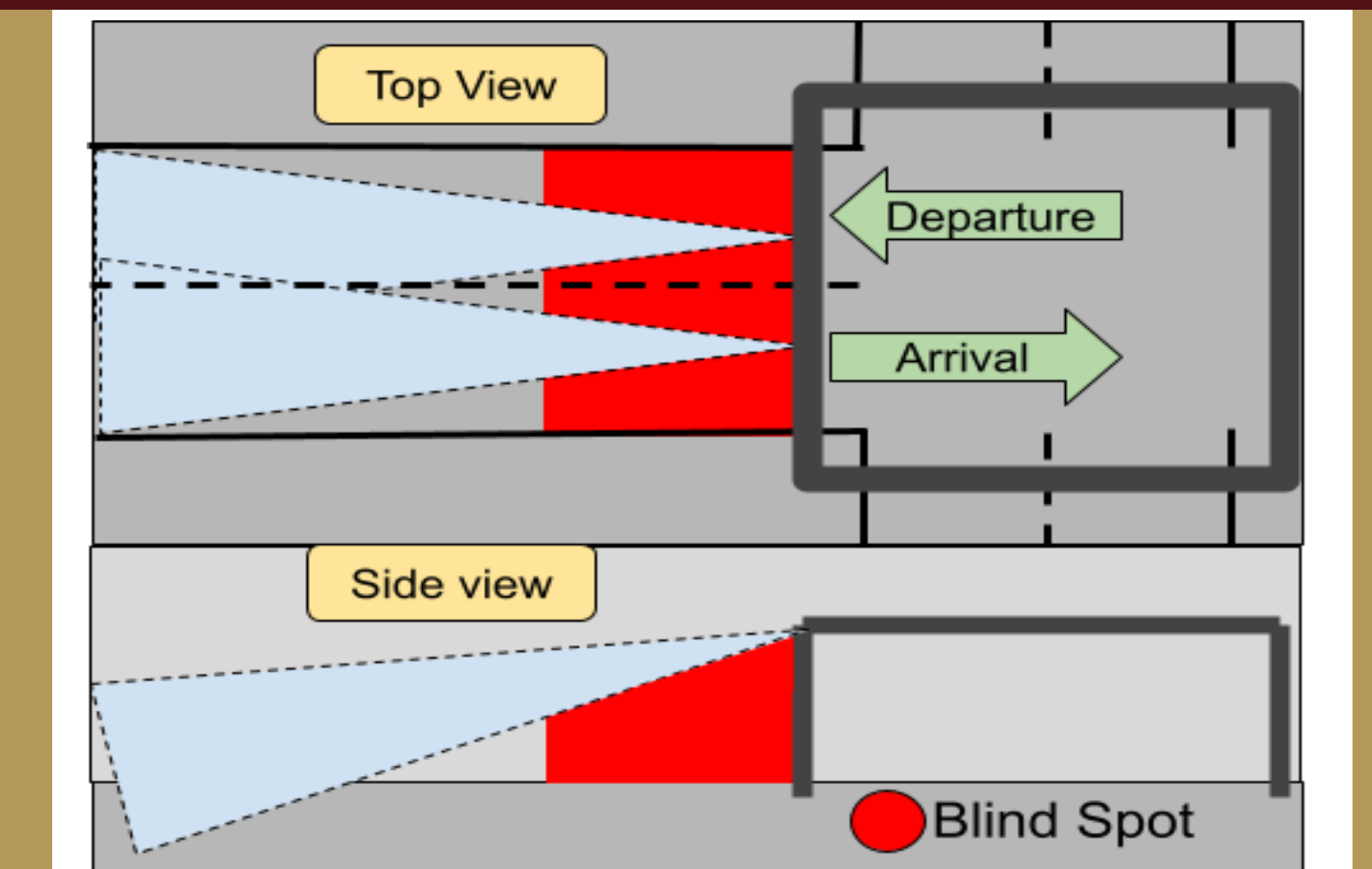

## OpenPLC Function / Communication Blocks

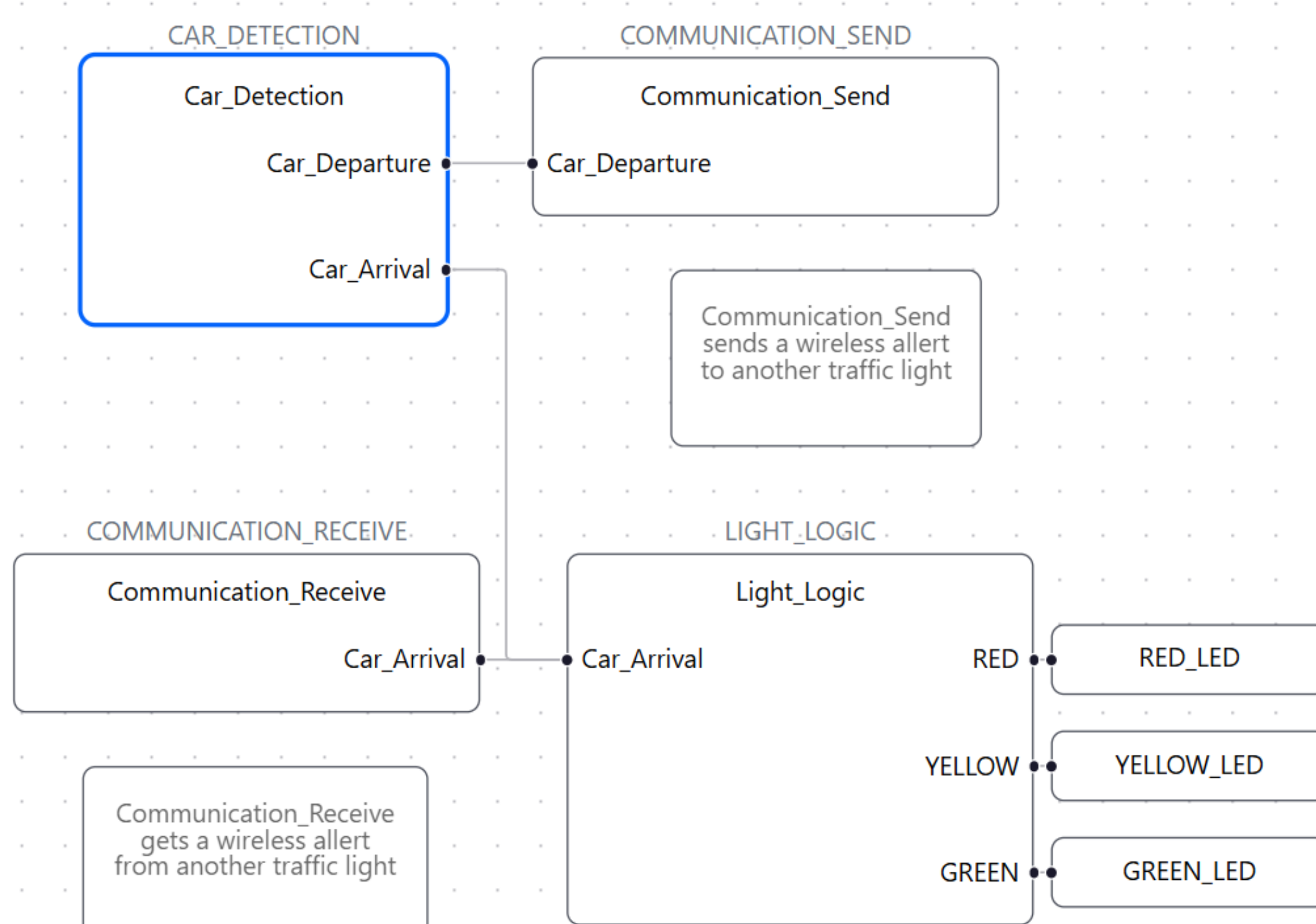

## Light Logic State Diagram

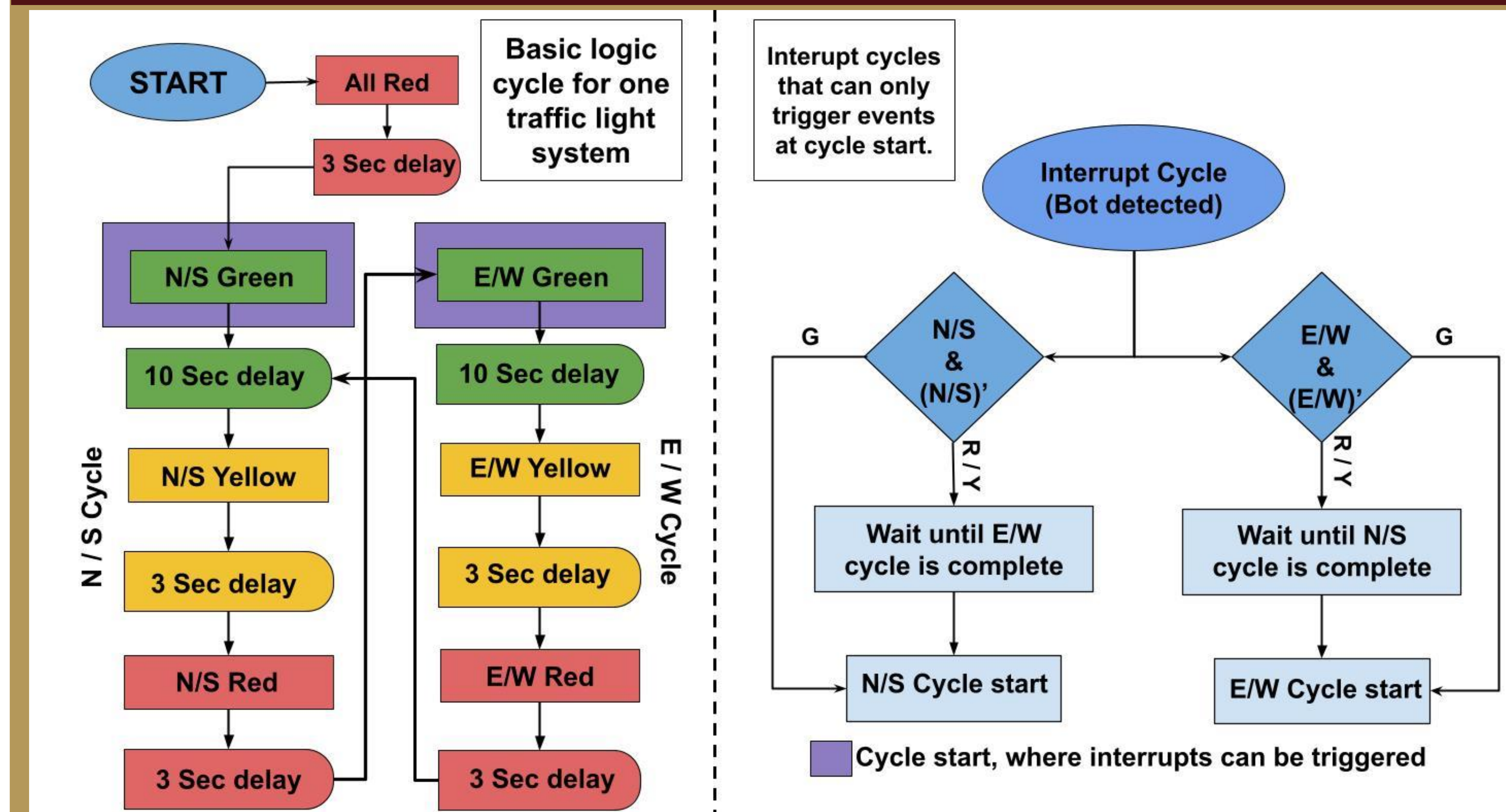

## Cost Per Traffic Light

Component	Quantity	Price Each	Subtotal Cost
ESP32-WROOM	1	\$5.33	\$5.33
VL53L0X Time-of-Flight	8	\$2.98	\$23.81
3.7V 18650 Batteries	2	\$4.25	\$8.50
LM2596 DC-DC Buck Power Converter Module	2	\$7.99	\$3.99
MOSFET Trigger Switch Drive Module	6	\$0.92	\$5.49
<b>Total Unit Cost</b>			<b>\$47.13</b>

## D2 Requirements

- Full design integration with a physical model and PCBs.
- Complete logic for standard and edge cases.
- Two or more traffic lights with live communication.
- Car detection that alters sequential light operation.
- Optimized light operation and bot wait time.