

Reece Cavallo, West Masone, Kira Smith, and Ethan Wilfur

## Problem Statement

Bobcat Racing, Texas State's FSAE chapter, requested the development of a hydraulic suspension system that can decouple the 4 modes of motion for current and future FSAE vehicles. They specified that the design should increase their ability to tune the vehicle's suspension response and require no electronic control.

## Deliverables

This project's deliverables include a miniature model, MATLAB program for optimization, and a CAD model for the current FSAE car, BR24.

## Project Background

Vehicle suspensions encounter 4 modes of chassis motion: heave, pitch, roll, and warp. Typical mechanical suspensions' responses to these modes are interconnected and cannot be separated from one another. Hydraulic suspension allows chassis motion to direct fluid flow to a desired spring/damper unit, allowing for mode-specific tuning.

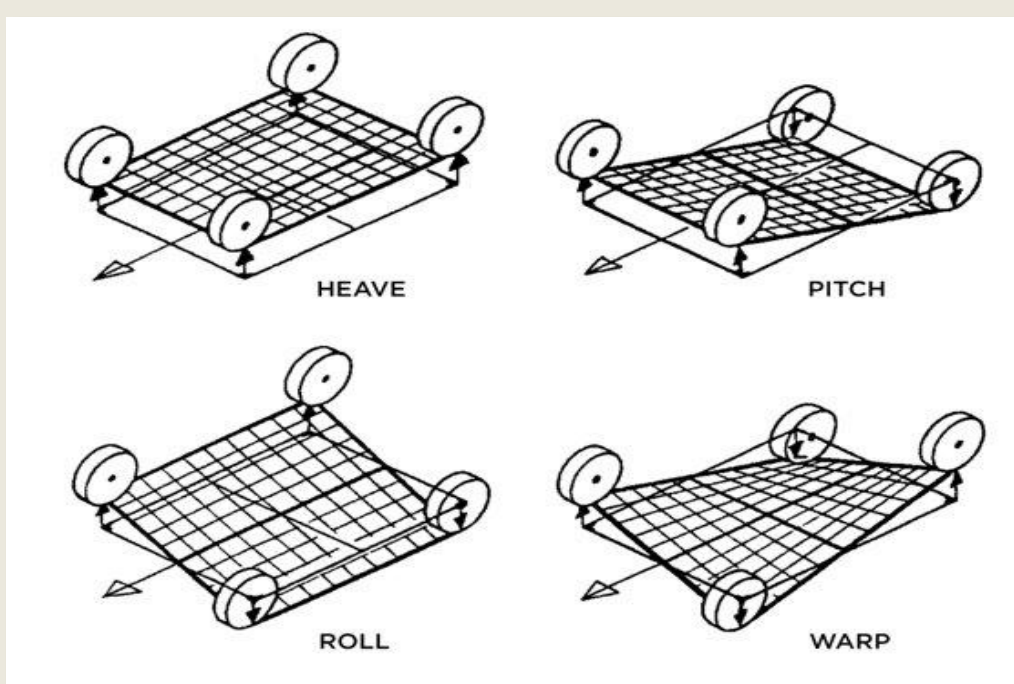

Source: www.racecar-engineering.com

## Acknowledgments

Sponsor: Bobcat Racing

Technical Faculty: Dr. Ebrahimi, Dr. Gonezen, Dr. Schieni, and Dr. Talley

## Design Overview

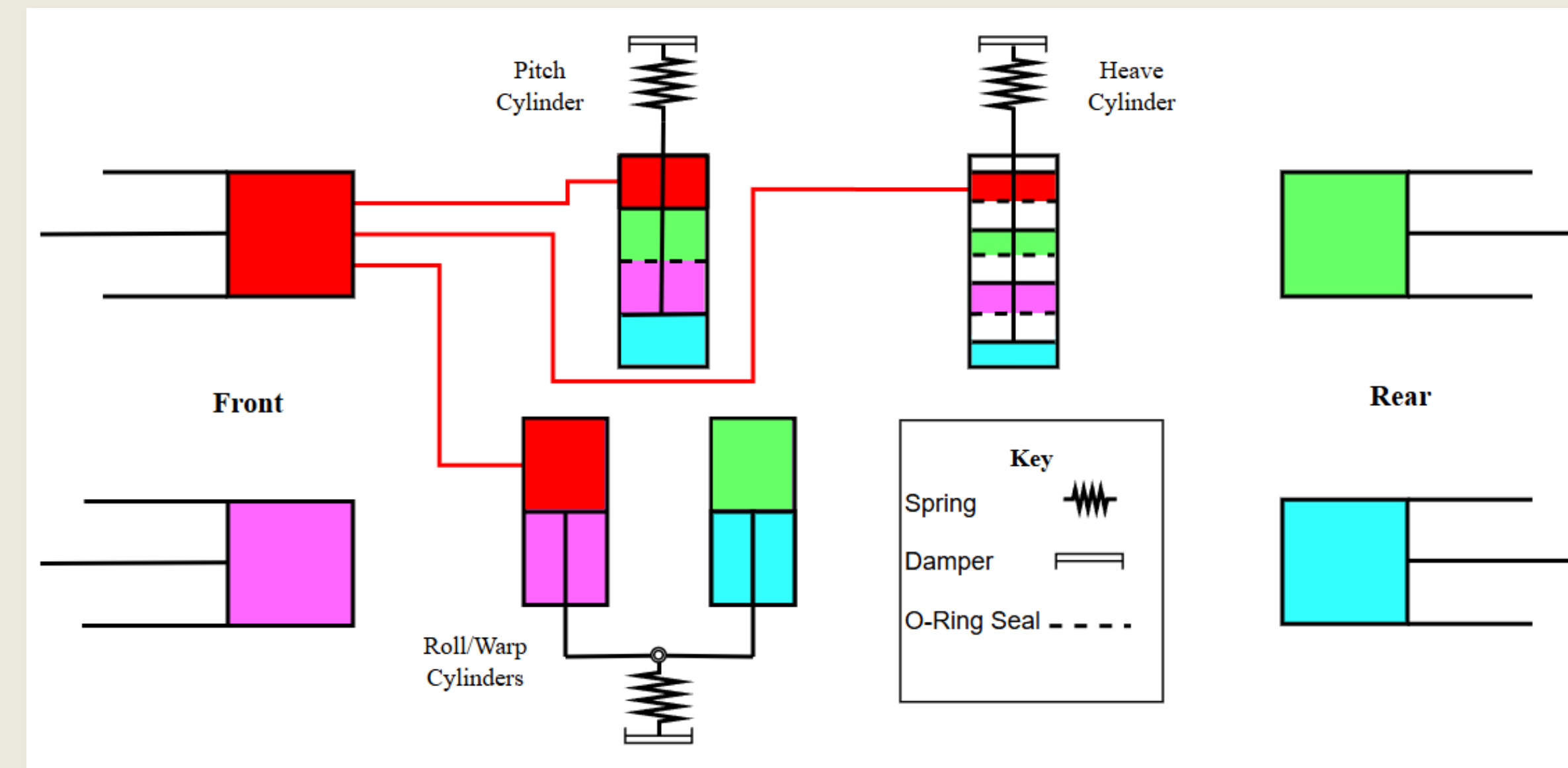

Final Schematic of Hydraulic Suspension

Our final design features single-acting cylinders mounted in line with each wheel's push rod. These cylinders respond to vertical tire-chassis displacement and direct hydraulic fluid to the mode-specific cylinders attached to spring and damper units. Roll and warp are combined as a two-cylinder system to facilitate the separate tuning of front and rear roll, while allowing warp to remain damped but unsprung. Pitch and heave are each moderated by a quad chamber cylinder. Each tire has an isolated hydraulic fluid system, which directs tire movement in a specific mode to actuation in only the appropriate mode cylinder.

## Miniature Model

### Timeline for Miniature Model

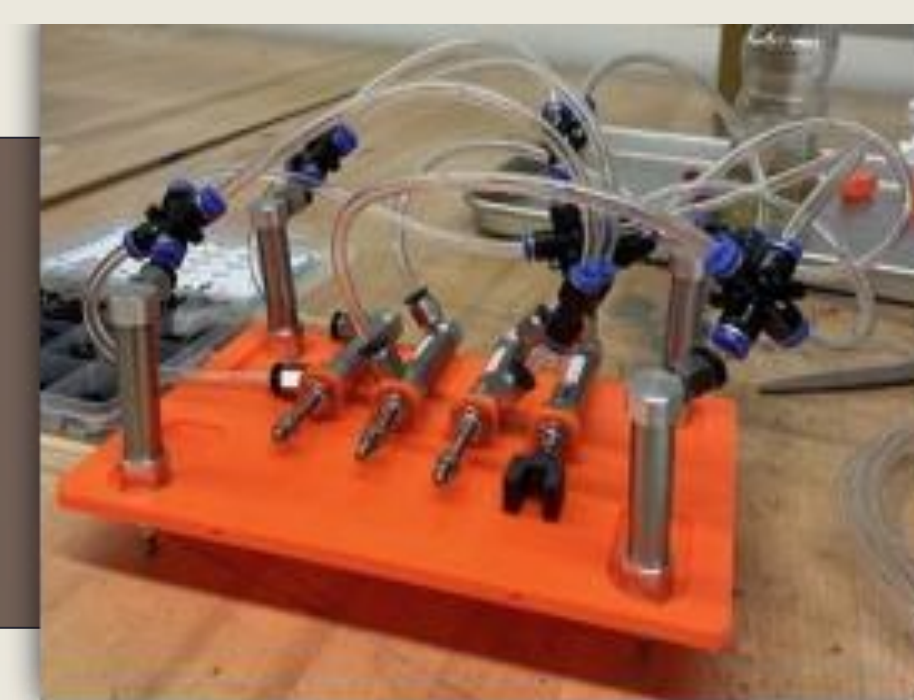
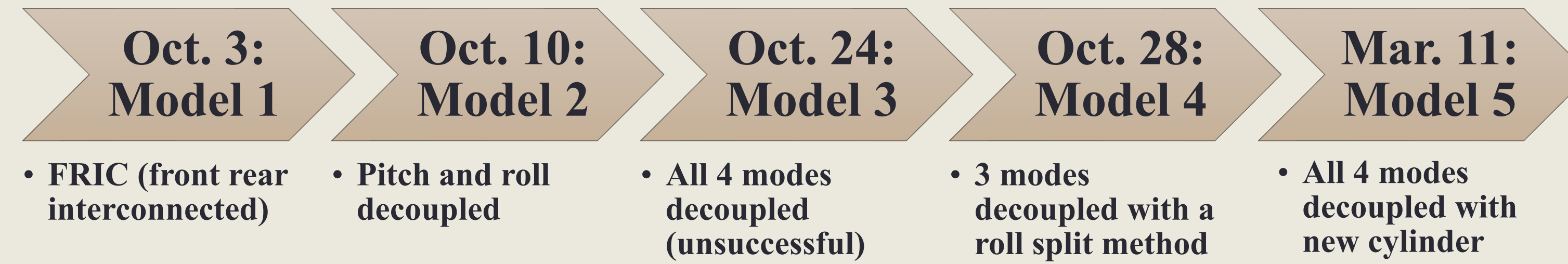

Model 2

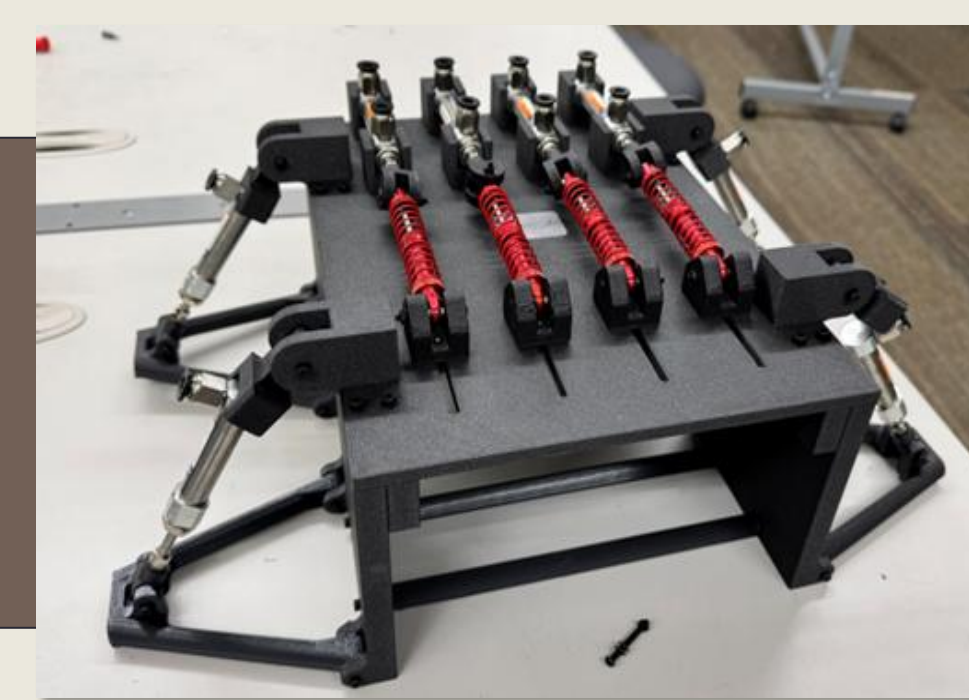

Model 3



Model 5

### Manufacturing



Heave Piston



Single Heave Quad Chamber Module

### Heave Cylinder

- Cylinder barrel SLA-printed on Elegoo Mars Pro 2
- 6061 aluminum piston machined on Kingston manual lathe

## CAD Models

### Miniature Model

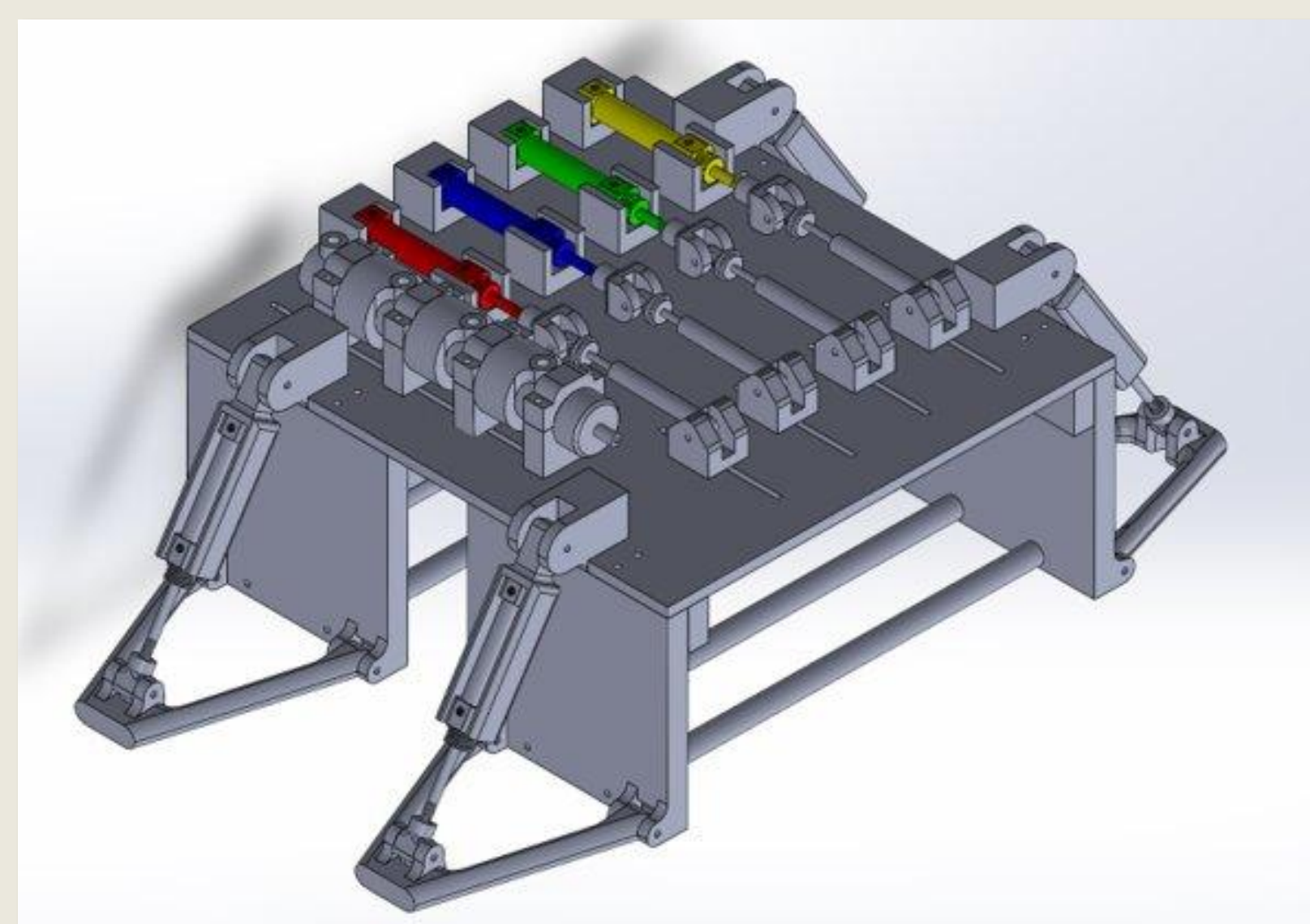

CAD of Miniature Model

### BR24

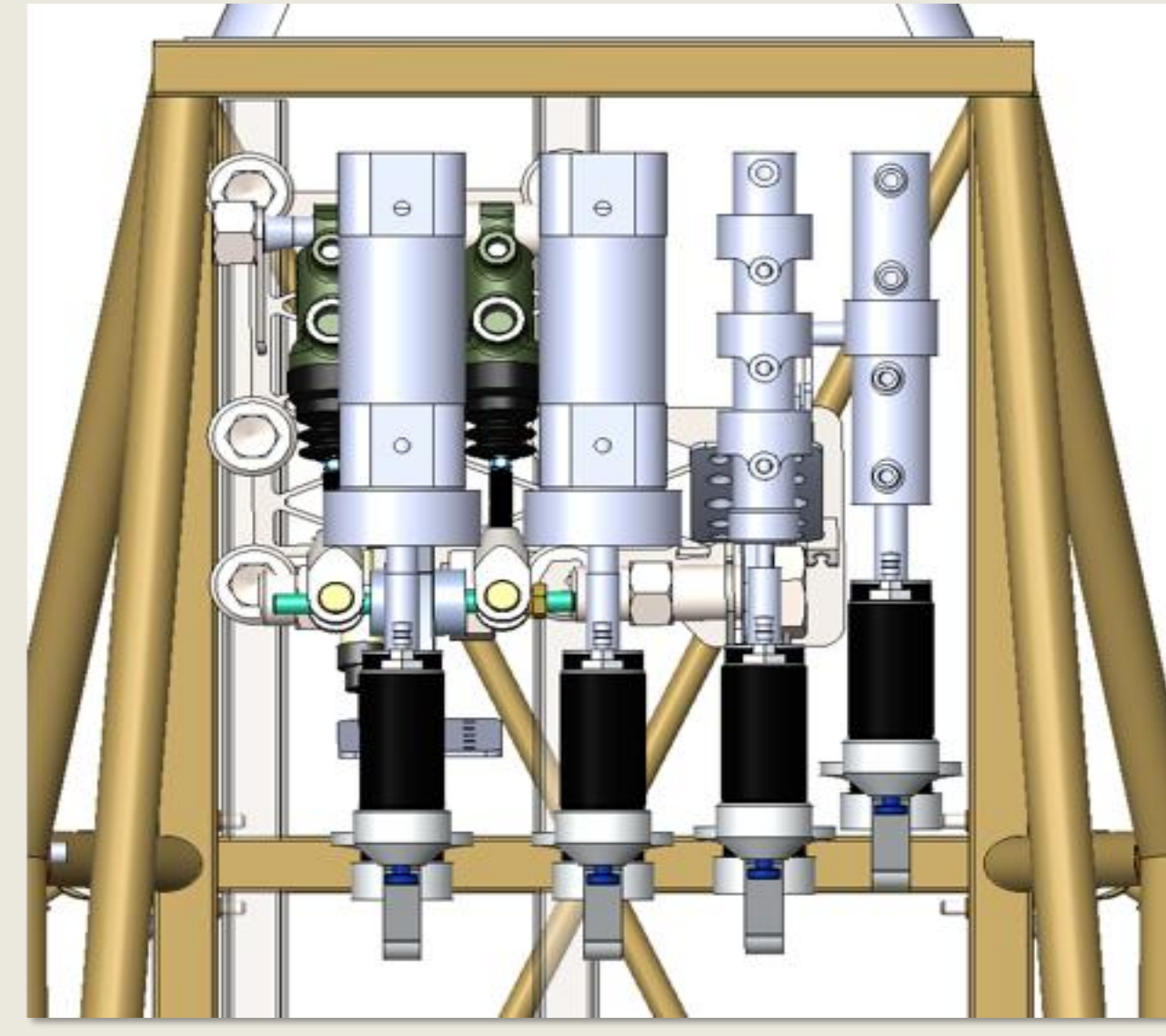

Mode Cylinders on BR24



Double Acting Roll Cylinder Cross-Section

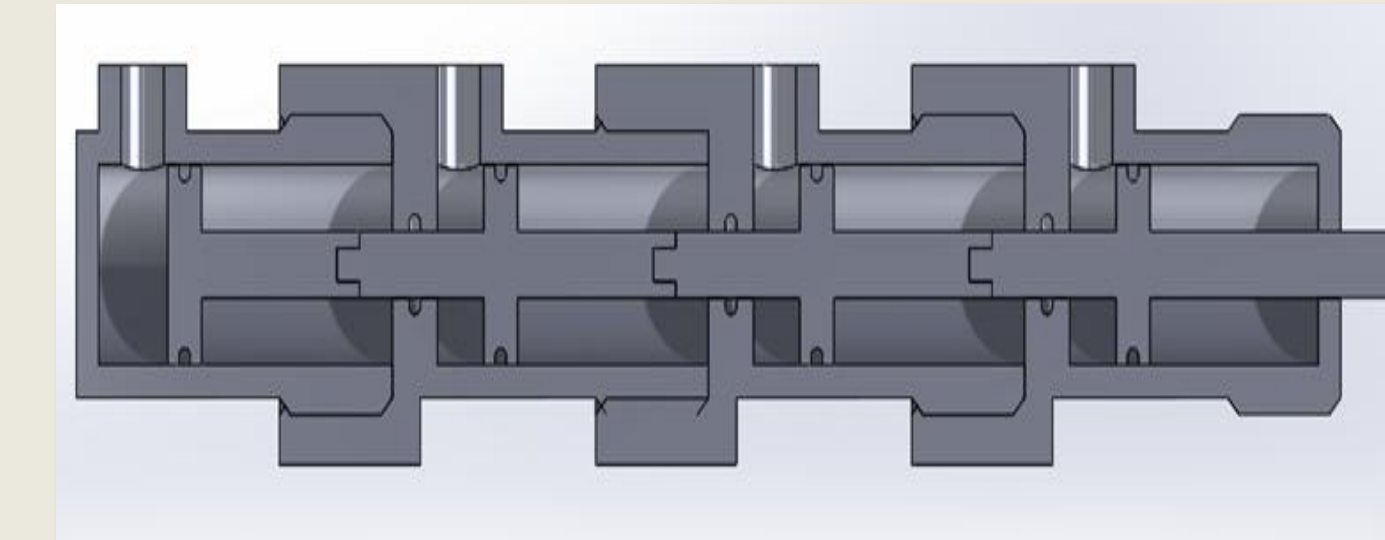

Quad Chamber Single Acting Heave Cylinder Cross-Section

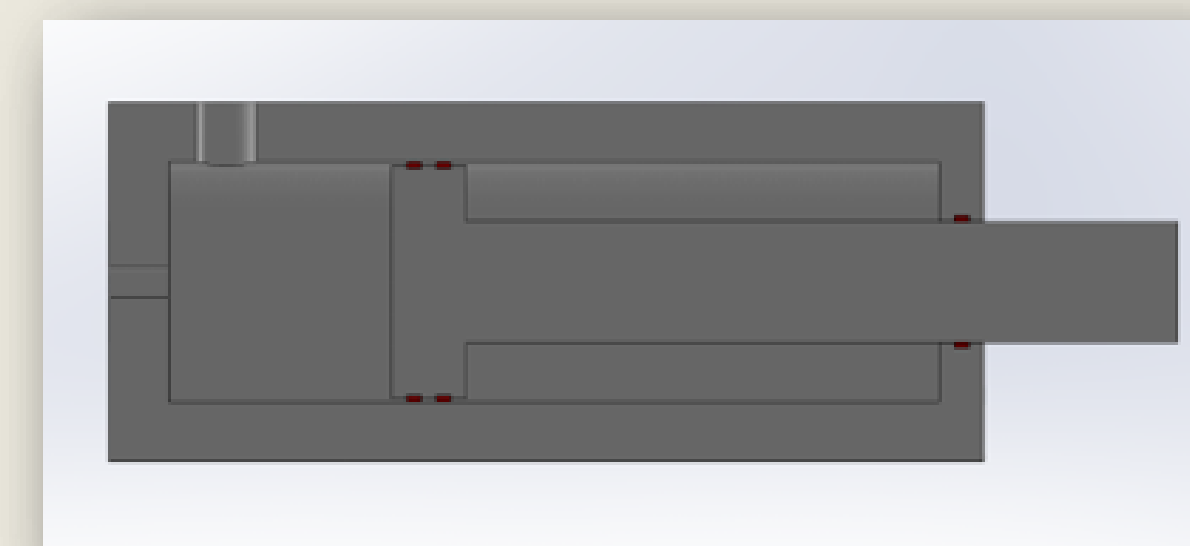

Single Acting Tire Cylinder Cross-Section

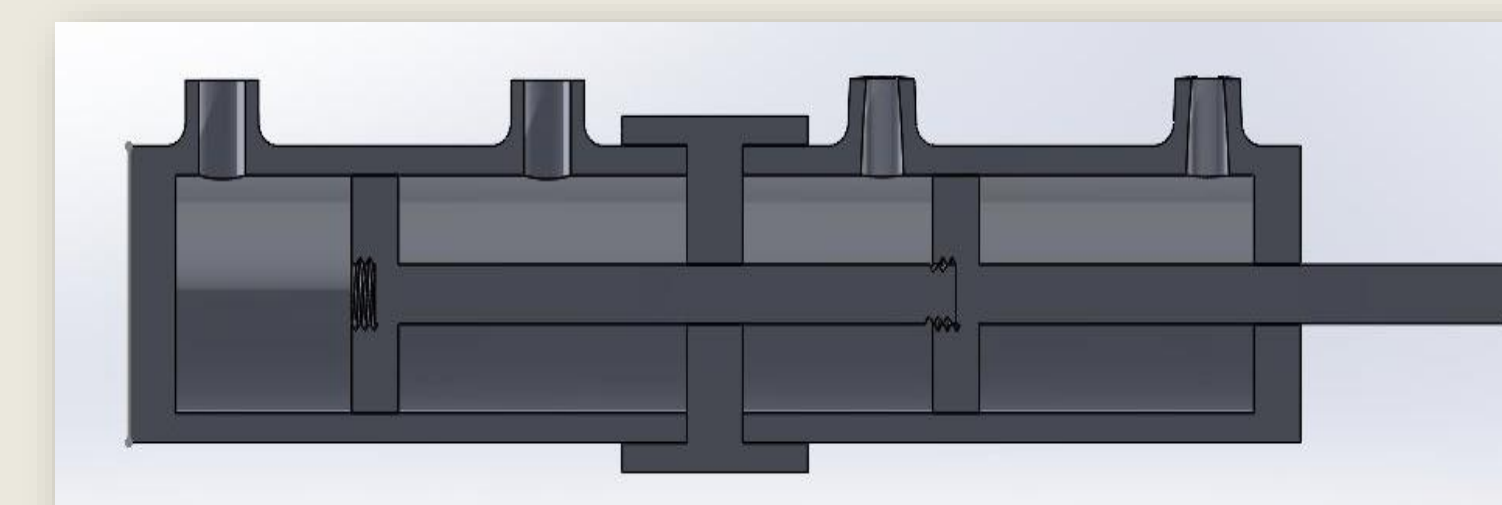

Quad Chamber Double Acting Pitch Cylinder Cross-Section

## MATLAB Program

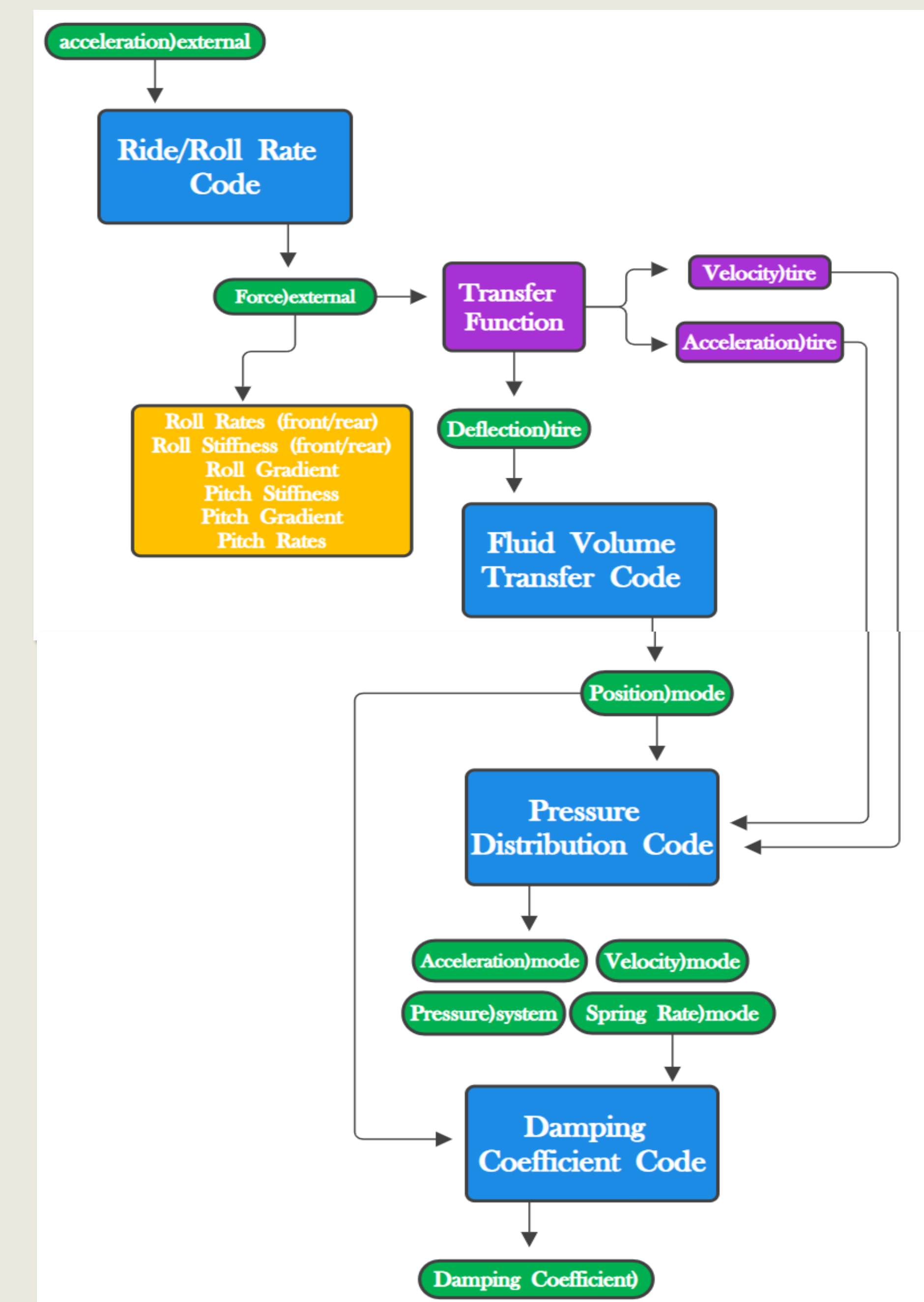

MATLAB Code Flowchart

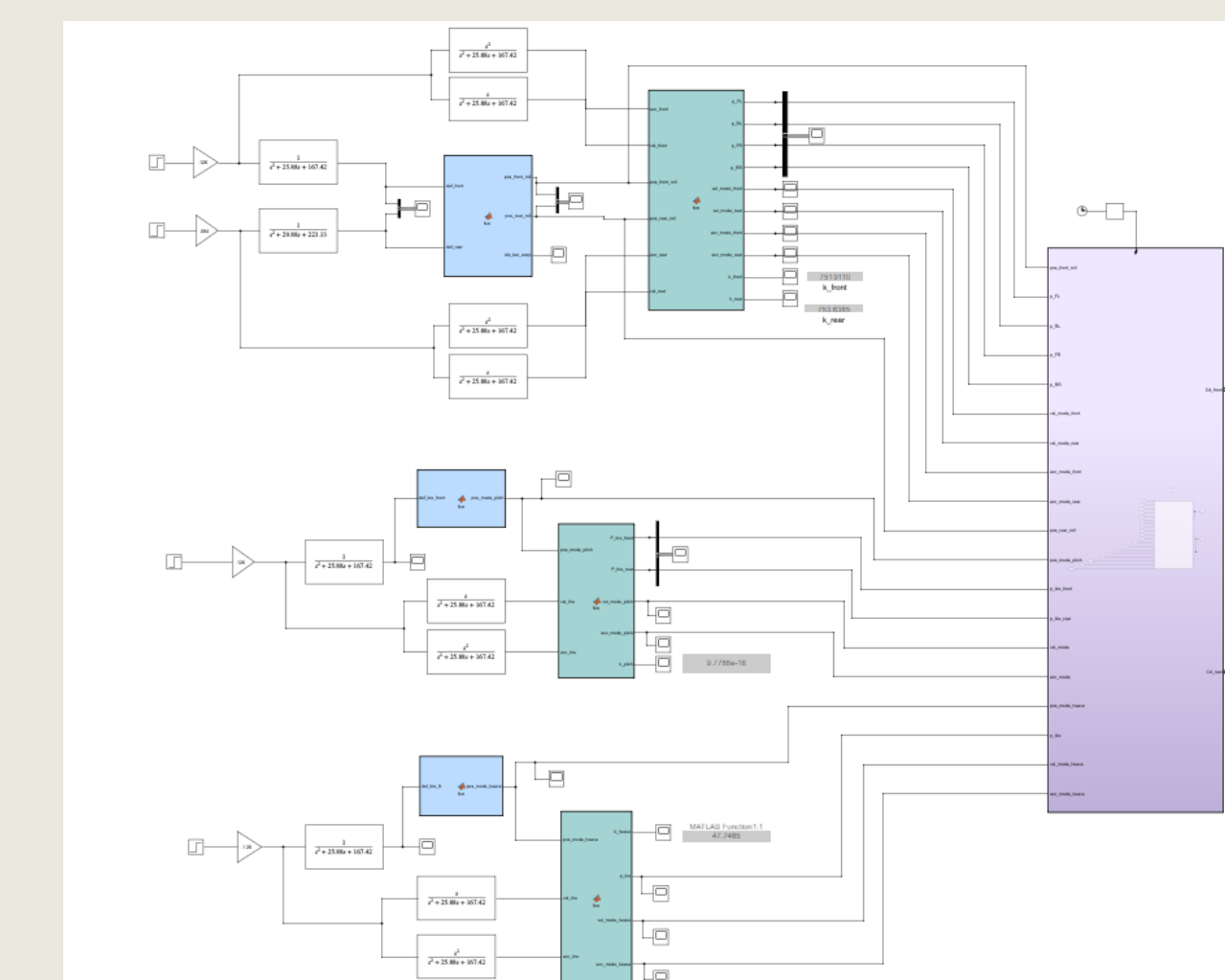

Simulink File



Tire Displacement Signal

The MATLAB program predicts the suspension's response to vehicular motion based on variable vehicle geometry inputs. The program takes max expected acceleration cases along with max desired tire-chassis deflection and outputs necessary modal spring rates and damping coefficients. Vehicle parameters are input into a GUI, used in a Simulink file, and outputs are returned neatly in a table.

## What's Next?

Using our design, future Bobcat Racing teams can implement the full-sized system into their vehicles, allowing for potential validation testing of the MATLAB program.