



# Group M2.01 - Lighthouse Project

**Adalberto Lozano Jr, Owen Coyne**

Instructor: Dr. Bahram Asiabanpour

Sponsor: Center for High Performance Systems (CHiPS), Ingram School of Engineering



## Project Description

Design and present a working automated system as a improved system to the current manual press system. The system will include employee as quality assurance operator (QA). We aim to improve cycle times and improve operator safety.

This manufacturing process utilizes a pneumatic press to punch a hole into an EZ Cap intended to be used on a bendable pen. These pens are recommended to be used in areas where personal safety is a concern.

## Background

The West Texas Lighthouse for the Blind has been impacting the community of San Angelo since 1963. Of which employs people who are blind or have severe vision impairment.

## Design

The system is made up of 3 major sub systems: Loading, WIP, and Unload.

The loading system uses 2 vibratory bowls to arrange caps into two single file lines, which then enter a track system, feeding an orienter which uses the hollow nature of the EZ Caps to orient all caps the same way.

The WIP (Work In Progress) system is responsible for conveyance of the caps from the loading station to the press, uses the press to punch a hole in the caps, then moves the parts to the offload station.

The offload system removes the punched cap from the WIP system and safely delivers finished parts to QA operators.

## Digital Models of Prototype(s)

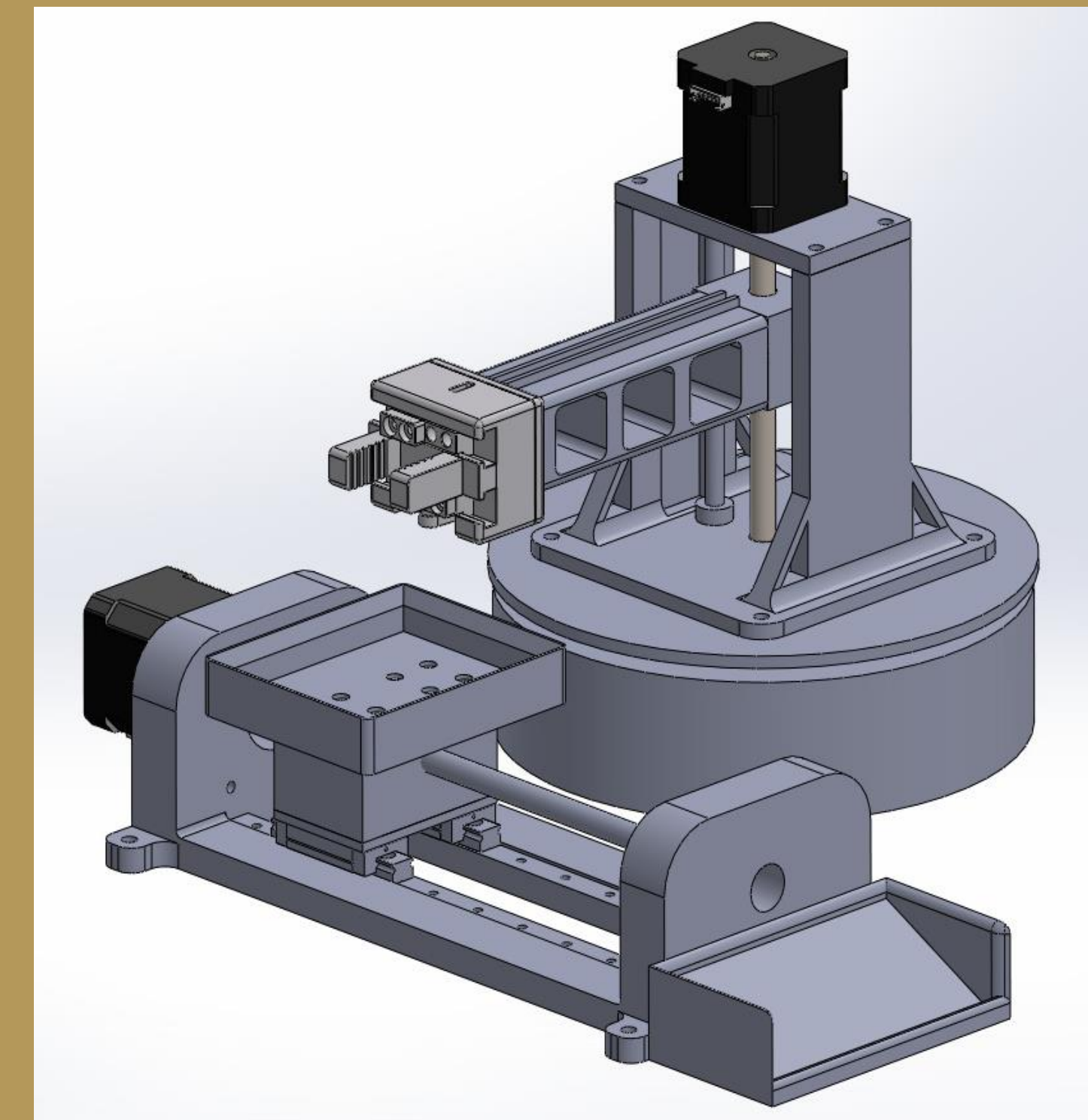
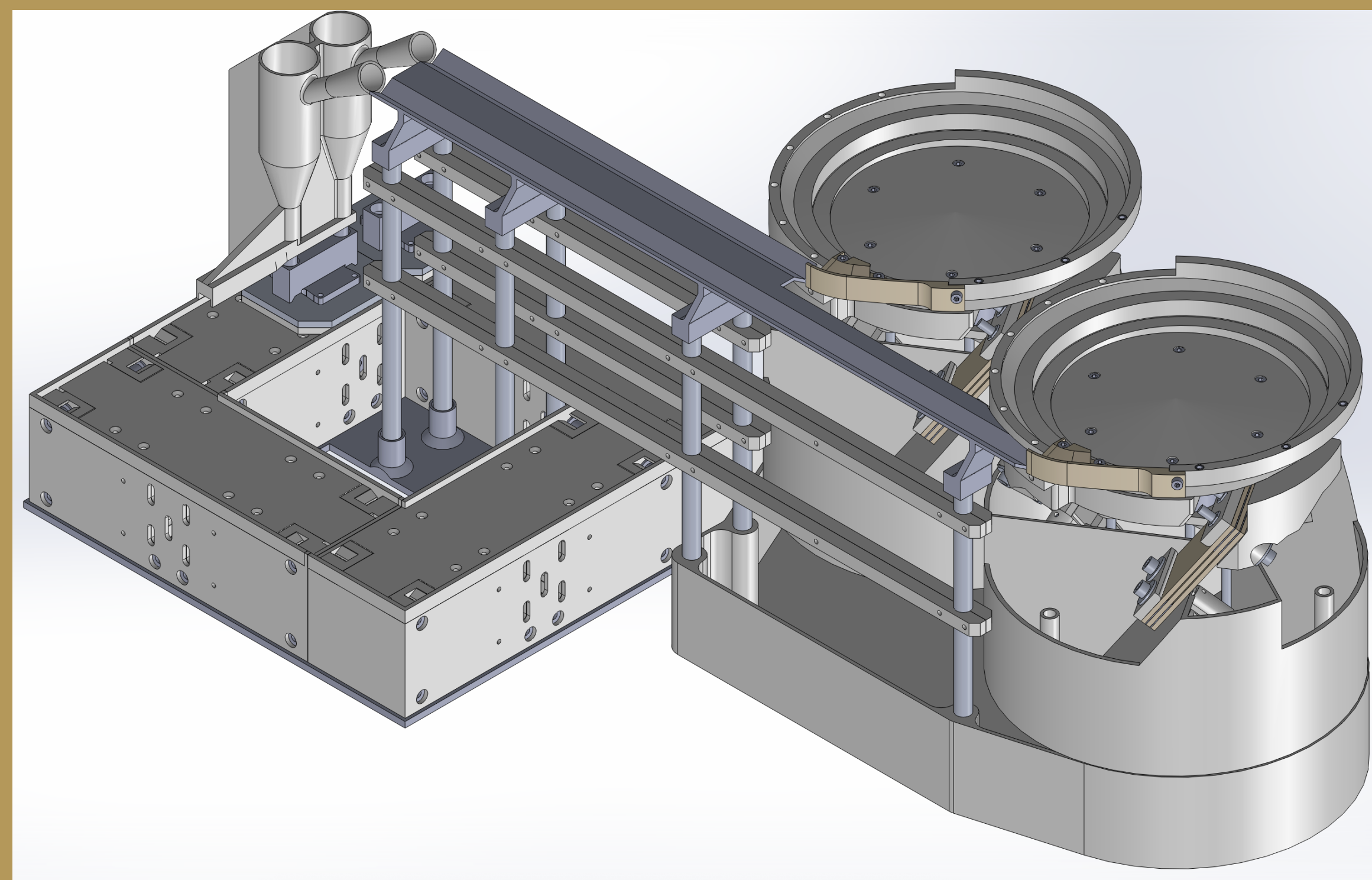

## Auxiliary Views & Physical Prototypes

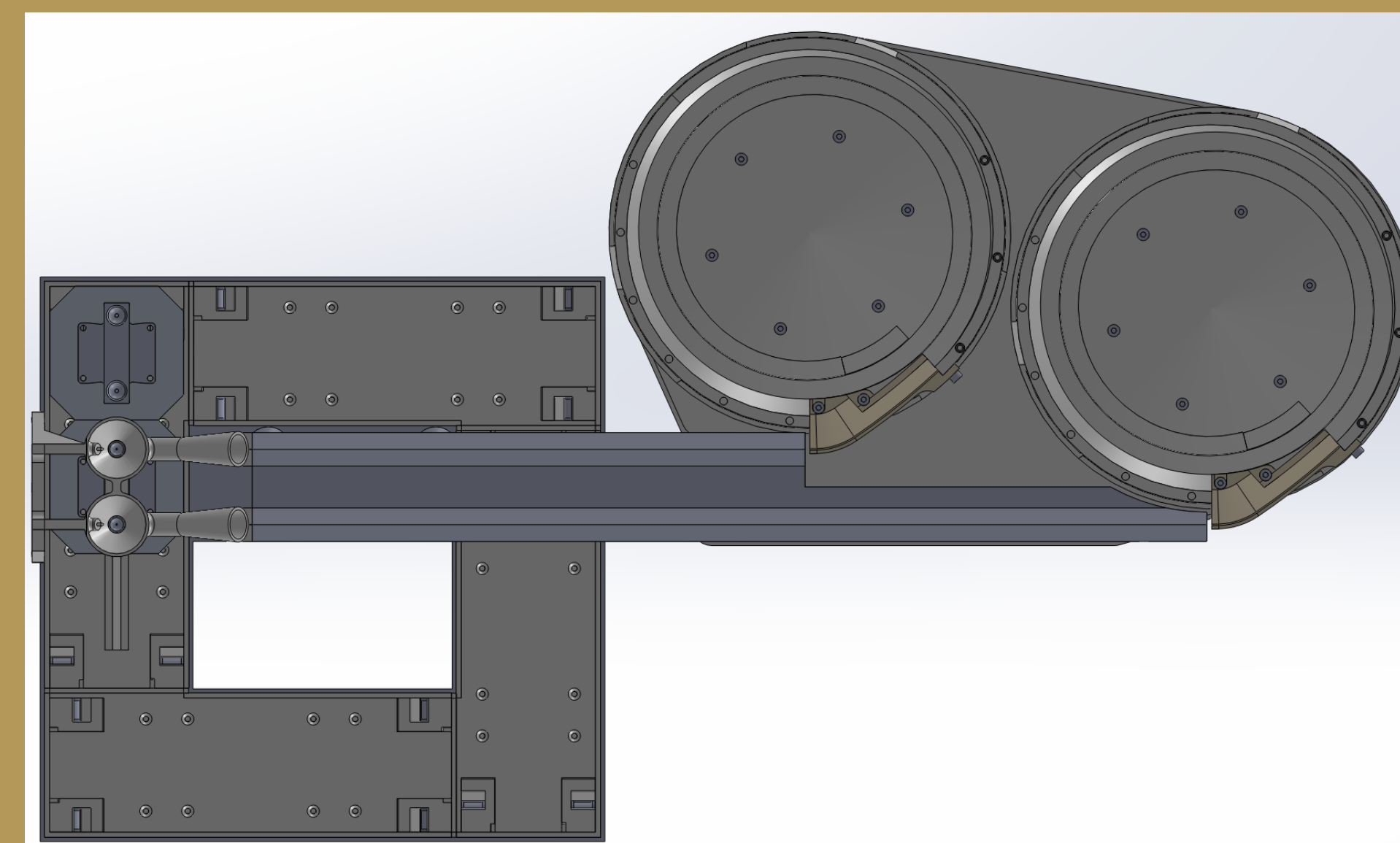

Top View of Conveyance & Bowls

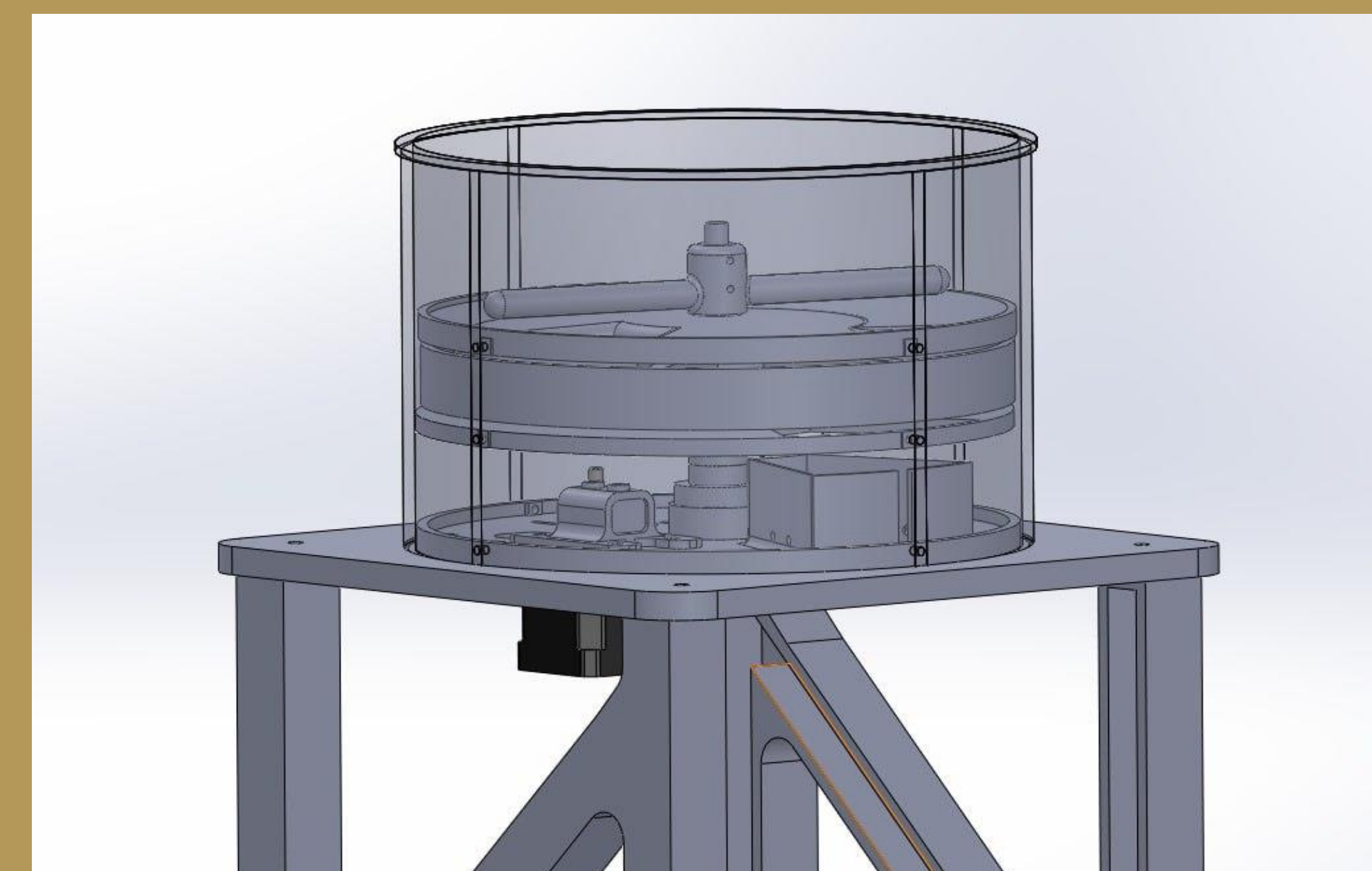

Isometric View of Bulk Feeder



Top View of the Vibratory Feeder with EZ Pen Caps

## Results

- Our project was successful in a few key areas:
1. First principles application to orientation system, reducing # of parts from ~100 to 1 & Total cost from \$2,000 to \$50.
  2. Successful design of conveyance system to eliminate operator risk
  3. Initial design completion for all sub systems
  4. Successful implementation of bowl feeder as requested by CHiPS lab
  5. Minimal maintenance required, helping with uptime & reliability
  6. Simple controls schema for future Sr. Design teams to build off of

## Processes

- Process Flow:
1. Bulk Bag Unload (Bulk Feeder)
  2. Linearization (Vibratory Bowl)
  3. Orientation (Orienter)
  4. Conveyance Stage 1 (Pallet, To Press)
  5. Hole Creation (Punch)
  6. Conveyance Stage 2 (Pallet, To unload)
  7. Offload (Arm Grabber Tower)
  8. Delivery (Linear Rail)

## Meet The Team

